

NEW

# PiLoTREK WE-200

COMPACT 80 GHZ (W-BAND) RADAR  
FOR LIQUIDS & SOLIDS

5 YEARS WARRANTY



# NIVELCO

LEVEL TRANSMITTERS

## FEATURES

- 2-wire 80 GHz (W-band) radar
- Measuring range up to 30 m (98.5 ft) for liquids
- Accuracy of  $\pm 2$  mm ( $\pm 0.078$ " )
- Small antenna diameter for easy installation
- Plug-in graphic display module
- Horn and plastic encapsulated antennas
- IP66 / IP67 protection
- User-friendly threshold management
- Configuration via Bluetooth® with MobileEView app
- PACTware™ compatible
- NIFLANGE weldable stainless steel flange options
- Ex version

## APPLICATIONS

- For level measurement of liquids, emulsions and other media
- For large particle bulk solids
- Storage tanks, chemical tanks, open pits, sumps, wells
- Measurement through a plastic tank roof
- For materials that tend to vaporize

- For measuring liquids with a gas blanket
- It can also be used in a vacuum
- Open-channel flow measurement

## CERTIFICATES

- ATEX (Ex ia GD)
- IECEx (Ex ia GD)
- ANATEL

## AREAS OF APPLICATION

- Water and Wastewater Industry
- Energy / Utilities
- Food & Beverage
- Chemical & Pharmaceutical
- Agriculture
- Construction Materials
- Heavy Industry
- Packaging Industry



WEP-214-4



WES-214-4



WES-212-4



WEK-224-4-X01

The new **PiloTREK WE-200** non-contact radar level transmitters use the most advanced industrial measurement technology, the 80 GHz FMCW radar. The most fundamental advantage of 80 GHz radar compared to lower frequencies (5...12 GHz and 25 GHz) is the smaller antenna size, better focusability, and narrow beam angle. It uses the latest technology to measure liquids, masses, emulsions and other chemicals widely used in the water, food, energy, pharmaceutical and chemical industries, providing measurement results with millimeter accuracy. It is also excellent for measuring substances that tend to vaporize and liquids with a gas blanket or large-particle bulk solids.

In addition to the level, volume, and weight measurement functions, this product family also inherits the open channel flow measurement functions and the threshold functions to eliminate false and interfering echoes. Since no medium is required for millimeter waves to propagate, it can also be used in a vacuum.

The device can also be operated with HART®-compliant NIVELCO **EView2**, **MultiCONT** universal process controller, and **PACTware™** software, or programmed via Bluetooth® communication with the new **MobileEView** app.

## OPERATING PRINCIPLE

The reflection of millimeter waves is highly dependent on the dielectric constant of the medium. Therefore, the dielectric constant ( $\epsilon_r$ ) of the medium to be measured must be greater than 1.9 for millimeter-wave level measurement.

Informative $\epsilon_r$ values							
Butane ( $C_4H_{10}$ )	1,4	Ethers	4,4	Gasoline	2,3	Methyl alcohol ( $CH_3OH$ )	33,1
LP gas	1,6...1,9	Acetic acid ( $CH_3COOH$ )	6,2	Bitumen	2,6	Glycol ( $C_2H_6O_2$ )	37
Kerosene		Limestone	6,1...9,1	Carbon disulfide ( $CS_2$ )		Nitrobenzene ( $C_6H_5NO_2$ )	40
Crude Oil	2,1	Ammonia ( $NH_3$ )	17...26	Clinker	2,7	Glycerin ( $C_3H_8O_3$ )	41,1
Diesel Oil		Acetone ( $C_3H_6O$ )	21	Resin	2,4...3,6	Water ( $H_2O$ )	80
Benzol ( $C_6H_6$ )	2,2	Ethyl alcohol ( $C_2H_5OH$ )	24	Cereal Grain	3...5	Sulfuric acid ( $H_2SO_4$ ) ( $T = 20\text{ }^\circ\text{C}$ [+68 °F])	84

The measurement principle of a level transmitter with a millimeter wave signal is based on measuring the reflection's time of flight. The propagation speed of millimeter wave signals in air, gases and vacuum is almost constant regardless of the temperature and pressure of the medium, so the measured distance is independent of the physical parameters of the intermediate medium. The **PiloTREK WE-200** level transmitter is a frequency modulated continuous wave (FMCW) radar operating at 80 GHz (W-band). The most obvious advantages of 80 GHz radars over lower frequency (5...12 & 25 GHz) radars are smaller antenna size, better focus, and smaller beam angle. A portion of the millimeter-wave continuous wave energy radiated by the level transmitter antenna is reflected from the measured surface, depending on the material to be measured. The distance of the reflecting surface is calculated with high accuracy by the electronics from the frequency shift of the reflected signal and converted into a distance, level, or volume signal by the electronics.

## TECHNICAL DATA

		Plastic housing W□P, W□M, W□V, W□F-2□□-□	Aluminum housing W□A, W□S, W□B-2□□-□	Stainless steel housing W□K, W□W, W□L-2□□-□
Measured values		Distance; calculated values: level, volume, mass, flow		
Signal frequency		77...81 GHz (W-band)		
Measuring range <sup>(1)</sup>		0...30 m (0...98.5 ft)		
Minimum beam angle <sup>(1)</sup>		7°		
Lowest $\epsilon_r$ of medium		1.9		
Resolution		0.1 mm (0.0039")		
Supply voltage		12...36 V DC		
Output	Analog	4...20 mA (3.9...20.5 mA); $R_{Lmax} = (U_S - 12\text{ V}) / 0.02\text{ A}$		
	Digital	Bluetooth® LE 5.1 (optional), HART® interface, loop resistance $\geq 250\ \Omega$		
	Relay (optional)	SPDT 30 V / 1 A DC; 42 V / 0.5 A AC		
	Service interface	Compatible with SAT-506-0		
	Display	SAP-300 – graphic display unit		
Measuring frequency		~ 1/s		
Antenna diameter <sup>(1)</sup>		1" (25.4 mm); 1½" (38.1 mm)		
Antenna material <sup>(1)</sup>		1.4571 (316Ti) stainless steel, or plastic antenna enclosure (PP / PVDF / PTFE)		
Process temperature		-40...+80 °C (-40...+176 °F), PP (W□P) sensor: -30...+80 °C (-22...+176 °F)	-40...+80 °C (-40...+176 °F), PP (W□A) sensor: -30...+80 °C (-22...+176 °F)	-40...+80 °C (-40...+176 °F)
Ambient temperature		-40...+70 °C (-40...+158 °F); with display: -20...+70 °C (-4...+158 °F)		
Process pressure		PP, PVDF, PTFE antennas: -1...3 bar (-0.1...0.3 MPa; -14.5...43.5 psi); Stainless steel antennas: -1...40 bar (-0.1...4.0 MPa; -14.5...580 psi)		
Process connection		1", 1½" BSP / NPT, prepared for welded flange		
Ingress protection		IP66 / IP67		
Electrical connection		2× M20×1.5 cable glands + 2× internally threaded ½" NPT connection, cable outer diameter: $\varnothing 6...12\text{ mm}$ ( $\varnothing 0.25...0.5"$ ) (shielded cable is recommended), wire cross section: 0.5...1.5 mm <sup>2</sup> (AWG20...15)		
Electrical protection		Overvoltage Class I; (Class III [SELV])		
Housing material <sup>(1)</sup>		Fiberglass-reinforced plastic (PBT)	Painted aluminum	Stainless steel 1.4571 (316Ti)
Weight		1...1.6 kg (2.2...3.5 lb)	2...2.6 kg (4.4...5.7 lb)	3.3...3.9 kg (7.9...8.6 lb)

<sup>(1)</sup>According to order code.

## TYPE-DEPENDENT DATA

	WE□-212-□ WE□-213-□	WE□-214-□ WE□-215-□	WE□-224-□ WE□-225-□
Dead zone <sup>(2)</sup>	0 m (0 ft)		
Maximum measuring range <sup>(3)</sup>	10 m (33 ft)		20 m (66 ft)
Accuracy <sup>(4)</sup>	±5 mm (±0.197")		±2 mm (±0.078")
Beam angle (-3 dB)	12°		7°
Antenna insertion length <sup>(5)</sup>	80 mm (3.15")		92 mm (3.62")
Process connection	1" BSP / NPT		1½" BSP / NPT

<sup>(2)</sup> Measured from the tip of the antenna.

<sup>(4)</sup> In the case of an ideal reflecting surface.

<sup>(3)</sup> May be limited in the case of low dielectric constant or non-perpendicular or non-planar media.

<sup>(5)</sup> Measured from the sealing plane of the process connection.

## Ex INFORMATION

Application group	IIC	IIIC
Standard version	WE□-2□□-8 Ex, WG□-2□□-8 Ex	
Ex marking (ATEX)	⊕ II 1G Ex ia IIC T6 Ga	⊕ II 1D Ex ia IIIC T85°C Da
High-temperature version	WH□-2□□-8 Ex, WJ□-2□□-8 Ex <sup>(6)</sup>	
Ex marking (ATEX)	⊕ II 1G Ex ia IIC T6...T3 Ga	⊕ II 1D Ex ia IIIC T85°C...T180°C Da
Ex power supply, intrinsically safety data <sup>(7)</sup>	U <sub>i</sub> = 30 V, I <sub>i</sub> = 100 mA, P <sub>i</sub> = 0.75 W C <sub>i</sub> ≤ 12 nF, L <sub>i</sub> ≤ 250 μH	U <sub>i</sub> = 30 V, I <sub>i</sub> = 140 mA, P <sub>i</sub> = 1 W C <sub>i</sub> ≤ 12 nF, L <sub>i</sub> ≤ 250 μH
Supply voltage	12...30 V DC	
Electrical connection	Cable entry	M20×1.5 cable gland
	Cable outer diameter	∅6...12 mm (∅0.25...0.5")
	Wire cross-section	0.5...1.5 mm <sup>2</sup> (AWG20...15)

<sup>(6)</sup> Under development

<sup>(7)</sup> In IIB applications, Ex power supply data for IIIC can be used.

## TEMPERATURE DATA FOR Ex CERTIFIED MODELS

	Standard version WE□-2□□-8 Ex, WG□-2□□-8 Ex	High-temperature version WH□-2□□-8 Ex, WJ□-2□□-8 Ex		
Temperature data	Ex ia IIC, Ex ia IIIC	Ex ia IIC, Ex ia IIIC		
Temperature class	T6 T85°C	T5 T100°C	T4 T135°C	T3 T180°C
Highest process temperature	+80 °C (+176 °F)	+100 °C (+158 °F)	+135 °C (+275 °F)	+180 °C (+356 °F)
Highest surface temperature at the process connection	+70 °C (+158 °F)	+100 °C (+158 °F)	+135 °C (+275 °F)	
Highest ambient temperature	+70 °C (+158 °F)	+70 °C (+158 °F)	+60 °C (+140 °F)	

## POLARIZATION

The **PiloTREK W-200** 80 GHz radar is much less sensitive to installation conditions, both in terms of polarization and clutter sensitivity, due to its narrow and nearly circular beamwidth.

## BACKGROUND MAPPING

Thanks to its 80 GHz FMCW technology, it is much less sensitive to the presence of clutter than previous generation radars. It now has an easy-to-use, flexible threshold management (*EView2*) that allows echoes from clutter in the tank to be easily masked if necessary. The threshold curve is designed to mask unwanted echoes from the measurement. Echo peaks below the threshold are not included in the evaluation.

## WIRING



## PROGRAMMING, ECHO MAP

All parameters can be programmed via the SAP-300 plug-in display; measurement and output parameters can be set using a text-based menu system.

Measured values are displayed as numbers and bar graphs on the dot-matrix screen. Echo Map helps detect false reflections and optimizes measurement configuration.

## MOUNTING

The device must not be mounted in the center of the tank or the inlet's proximity or the tank's outlet to avoid unwanted multiple reflections. The ideal position for the **PiloTREK** is on the  $r = (0.3 \dots 0.5) R$  in a cylindrical tank. The device must be mounted far as possible from interfering objects inside the tank and from sources of interference, such as waves, vortices or strong vibrations. The antenna cover must be parallel to the measured surface within  $\pm 2 \dots 3^\circ$ . Protect the instrument from direct sunlight to avoid overheating.

## PC CONNECTION

The **PiloTREK WE-200** series, equipped with HART® connectivity, offers enhanced functionality for industrial monitoring. Instruments can be connected to a PC using a **UNICOMM SAK-305** HART®-USB modem, allowing users to visualize all measured values on the PC screen. This feature is crucial for real-time data monitoring and analysis. Additionally, the HART® modem enables remote programming and configuration of the instruments, providing flexibility and ease of use.

A notable feature of the HART® system is its ability to support up to 15 non-Ex (*non-explosive environment*) instruments on a single loop, making it ideal for large-scale operations. The system's compatibility with **EView2** configuration software and **NIVISION** process visualization software further enhances its functionality, providing robust tools for effective process monitoring and control in a variety of industrial applications.

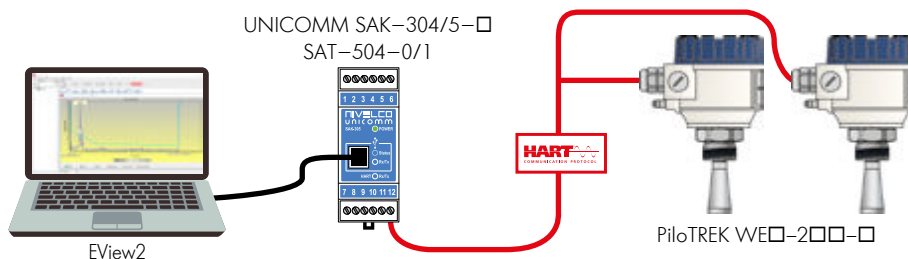

### Bluetooth® CONNECTIVITY

The **PiloTREK WE-200** level transmitter can be connected to a PC or cell phone via Bluetooth® wireless technology for configuration using **EView2** and **NIVISION** software or the new **MobileEView** application. **WE-200-B/-E/-R** devices can be connected directly, and **WE-200-4/-5/-8/-H/-F** devices can be connected using a **UNICOMM SAT-504-2** modem. This range of models and connectivity options makes the **PiloTREK WE-200** series adaptable for various industrial and monitoring applications.

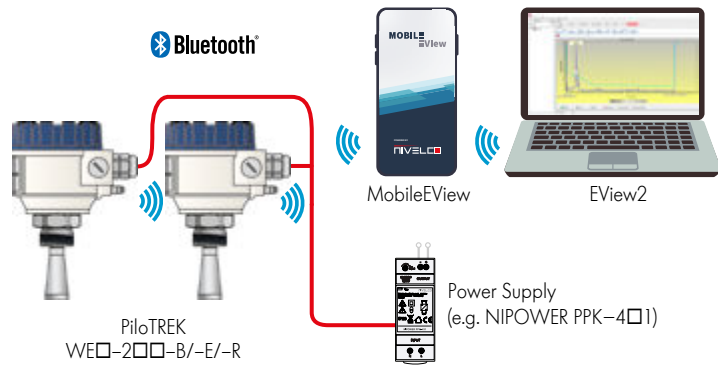

In the illustrated system, the SAT-504-2 modem must be used in passive HART® modem mode! Do not activate the built-in power supply of the modem while the transmitters are powered!

### PiloTREK TRANSMITTERS IN HART® MULTIDROP LOOP

**MultiCONT** multichannel process controllers process and display measurement data supplied by NIVELCO's HART® equipped transmitters in a Multidrop loop. Connected transmitters can be programmed through **MultiCONT**, and it can also perform data logging tasks. Processed data may be sent to a computer via RS485 and displayed in **NIVISION**. **MultiCONT** provides the means to optimize and configure measurements and display the echo maps of the particular installations.

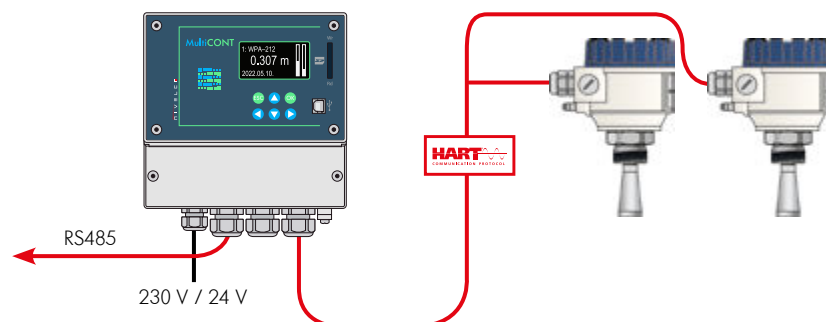

## DIMENSIONS

### Encapsulated antenna, plastic housing (W□P, W□V, W□F)

W□□-212-□ / W□□-213-□

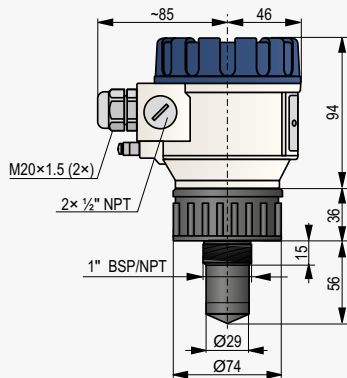

W□□-2□4-□ / W□□-2□5-□

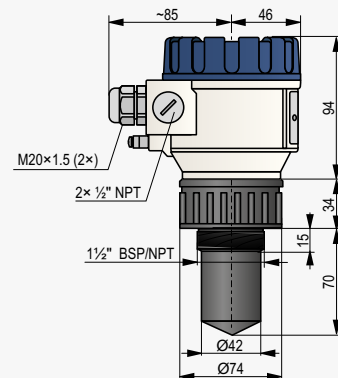

### Stainless steel antenna, plastic housing (W□M)

W□M-212-□ / W□M-213-□

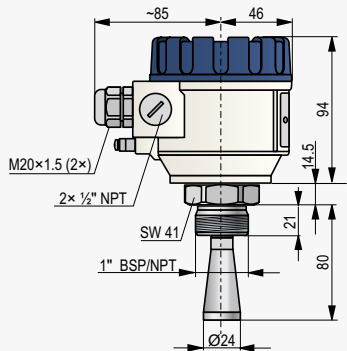

W□M-2□4-□ / W□M-2□5-□

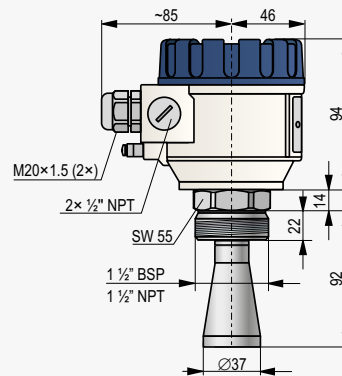

### Stainless steel antenna, aluminum housing (W□S)

W□S-212-□ / W□□-213-□

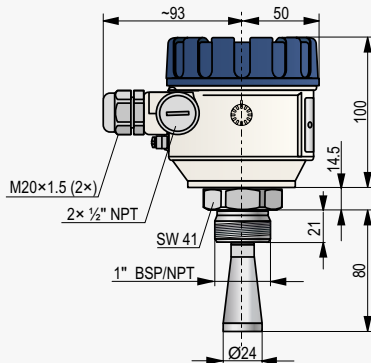

W□S-2□4-□ / W□□-2□5-□

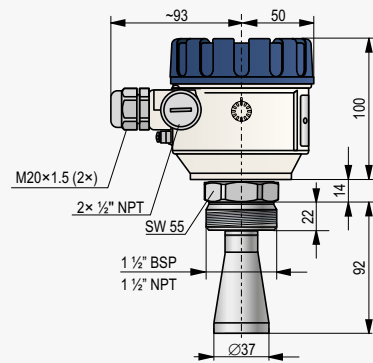

### Stainless steel antenna, stainless steel housing (W□K)

W□K-212-□ / W□K-213-□

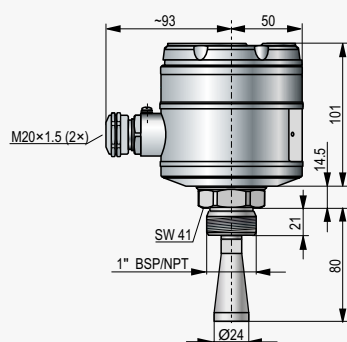

W□K-2□4-□ / W□K-2□5-□

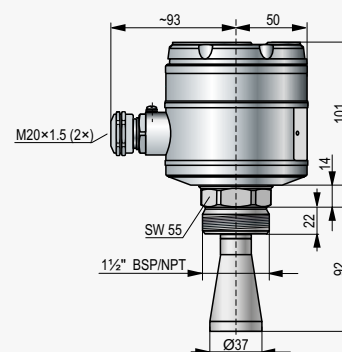

## ORDER CODES (NOT ALL COMBINATIONS AVAILABLE)

### Advanced 80 GHz Radar Level Transmitters

#### PiloTREK W ■ ■ - 2 ■ ■ - ■ (1)

Version	Code	Antenna / Housing	Code	Measurement range	Code	Process connection	Code	Output / Certificates	Code
Transmitter	E	Fiberglass-reinforced plastic (PBT)	P	10 m (33 ft)	1	1" BSP (4)	2	-	4
Transmitter with plug-in display	G	PP	Painted aluminum	A	20 m (66 ft)	2	1" NPT (4)	Ex ta D (2)	5
		1.4571	Fiberglass-reinforced plastic (PBT)	M	30 m (98.5 ft) (2)	3	1 1/2" BSP (5)	Ex ia GD	8
		1.4571	Painted aluminum	S		1 1/2" NPT (5)	5	+ Bluetooth®	B
		1.4571	Stainless steel	K		Ø75 mm (2 1/2") (2, 6)	8	+ Bluetooth® / Ex ia GD	E
		PVDF	Fiberglass-reinforced plastic (PBT)	V		Prepared for welded flange (7)	S	+ Relay	H
		PVDF	Painted aluminum	B				+ Relay / Ex ta D (2)	F
		PVDF	Stainless steel	W				+ Relay + Bluetooth®	R
		PTE	Fiberglass-reinforced plastic (PBT) (3)	F					
		PTE	Stainless steel (3)	L					

(1) The order code of an Ex version product should end with "Ex". (2) Under development. (3) Up to 20 m (66 ft) measuring range. (4) Only for 10 m (33 ft) measuring range. (5) Only for 10 m (33 ft) or 20 m (66 ft) measuring range. (6) Prepared for flange, only 30 m (98.5 ft) and encapsulated types, flanges available from size DN80 should be ordered separately. (7) Only for 10 m (33 ft) or 20 m (66 ft) ranges, with 1/2" stainless steel antenna, flange type MF□-□□□-L to be ordered separately.

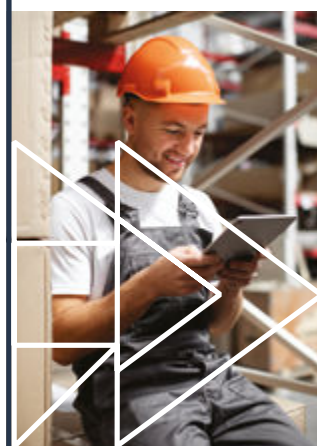
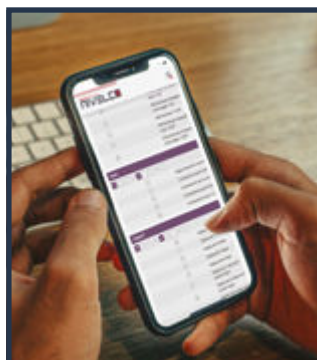

## NIVELCO Selector. Next Simplify Your Selection, Maximize Your Results!

Simplify the product selection process with the NIVELCO Selector to find the perfect product for your application. Our online product catalog provides a comprehensive list of all our products and their features to help you make an informed decision. A responsive interface provides a seamless browsing experience on any device, giving you the flexibility to explore our range anywhere, anytime.



**PiloTREK WE-200  
- CONFIGURATION &  
REQUEST FOR QUOTE**

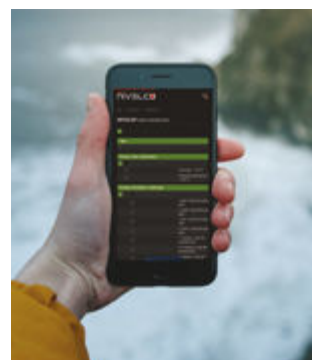

The project 2020-1.1.2-PIACI-KFI-2021-00278 was funded by the Ministry of Culture and Innovation through the National Research Development and Innovation Fund, under the Market-driven Research, Development and Innovation Projects (2020-1.1.2-PIACI-KFI) call for proposals.

