

# LPN-R RTD Transmitter.

Programmable Linearised 3 Wire RTD Input to 4~20mA Output Loop Powered Transmitter.

## Features.

- Field Programmable.
- Pt100 RTD Standard Input.
- High Accuracy 0.1%.
- Linear With Temperature
- 40~200mV Output Test Signal.
- LED Indication of Current Loop (CL).
- Low Cost.
- Easy to Install.
- Compact DIN Rail Mount Enclosure.
- Available Standard or Special Calibration.
- Reverse Polarity Protection.
- Available With One or

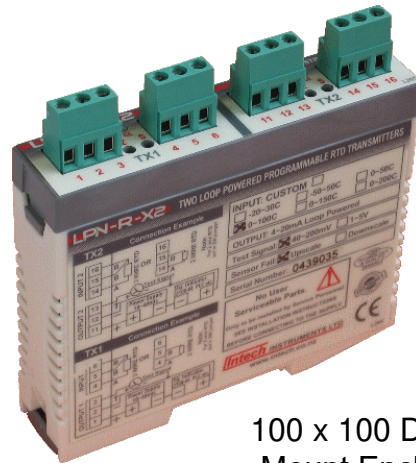

100 x 100 DIN Rail Mount Enclosure.

## Ordering Information.

LPN-R-X1 Standard 100x100mm DIN Rail Mount, Upscale Break, Pt100, 0~100°C Input.

LPN-R -  -  -  -   
EN SB ST Range. eg. -50/50C

ENCLOSURE (EN)		SENSOR BREAK (SB)		SENSOR TYPE (ST)	
E	IP67 Enclosure. L=110, W=80, H=65mm	U	Upscale	P	Pt100
X1	DIN Rail Mount; 1Tx. L=100, W=22.5, H=100mm	D	Downscale	S	SPECIFY

## Ordering Examples.

LPN-R-E-U-P 0~100C LPN-R; IP67 Enclosure; Upscale Sensor Break; Pt100 Input; 0~100°C.

LPN-R-X1-U-P 0~150C LPN-R; DIN Rail Enclosure; 1 Transmitter; Upscale Break; Pt100 Input; 0~150°C.

## Specifications.

RTD Input.	Pt100 DIN (3 Wire type). Other RTDs Available. Eg. Pt1000, CU10, or Specify.
Sensor Current.	0.5mA Nominal.
Lead Wire Resistance.	5Ω/Wire max.
Zero Range	-100C to 100C. (-165 to 210F)
Span Range	30C to 600C. (55 to 1080F)
Output	-mA 2 wire 4~20mA. (Loop Powered.)
	-mV Test 40~200mV ±1% ∞ 4~20mA. Other Test Voltages Available. e.g. 1~5V.
	Note. mV Test Increases Power Supply & Decreases Load Resistance.
Power Supply.	10~33Vdc. (Loop Powered).
Supply Voltage Sensitivity.	<±0.005%/V FSO.
Output Load Resistance	700Ω @ 24Vdc. (50Ω/V above 10Vdc.)
Maximum Output Current	Limited to <26mA Typical.
Sensor Fail	-Upscale 23mA Min. Typical.
	-Downscale 3.8mA Max. Typical.
EMC Emissions & Immunity Compliance	EN 55022-A & EN 50082-1
Safety Compliance.	EN 60950
Test Voltage Between Two X2 Units	1000Vac, 50Hz for 1 min.
Response time	200msec Typical. (From 10 to 90 % 50msec Typical.)
Accurate to	<±0.1% FSO Typical.
Linearity & Repeatability.	<±0.1% FSO Typical.
Ambient Drift.	<±0.01%/C FSO Typical
RF Immunity.	<1% Effect FSO Typical.
Operating Temperature.	0~70C.
Storage Temperature.	-20~80C.
Operating Ambient Humidity.	5~85% RH Max. Non-condensing.

**Product Liability.** This information describes our products. It does not constitute guaranteed properties and is not intended to affirm the suitability of a product for a particular application. Due to ongoing research and development, designs, specifications, and documentation are subject to change without notification. Regrettably, omissions and exceptions cannot be completely ruled out. No liability will be accepted for errors, omissions or amendments to this specification. Technical data are always specified by their average values and are based on Standard Calibration Units at 25C, unless otherwise specified. Each product is subject to the 'Conditions of Sale'.

**Warning:** These products are not designed for use in, and should not be used for patient connected applications. In any critical installation an independent fail-safe back-up system must always be implemented.

## Quality Assurance Programme.

The modern technology and strict procedures of the ISO9001 Quality Assurance Programme applied during design / development, production and final inspection grant the long term reliability of the instrument.

## Examples of LPN-R-D Connections.

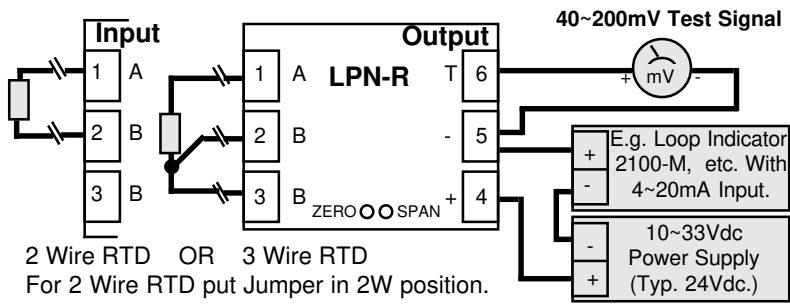

## Location of LPN-R-D Jumpers.

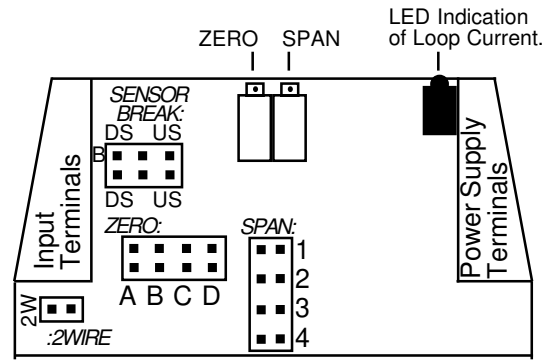

## Top Overview of LPN-R-X Terminals.

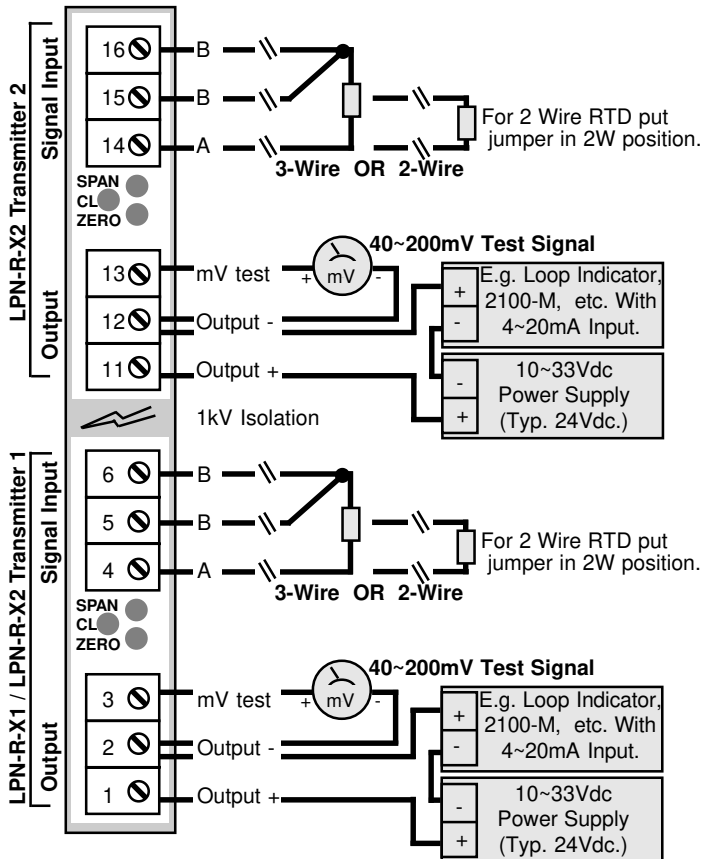

## Location of LPN-R-X Jumpers.

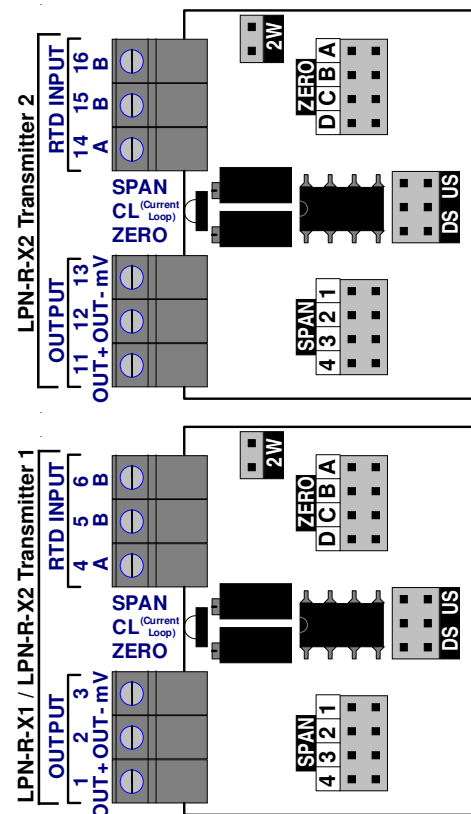

## LPN-R-D Terminations.

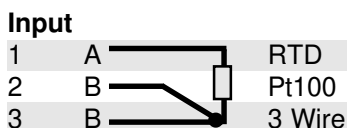

## LPN-R-X1 Terminations.

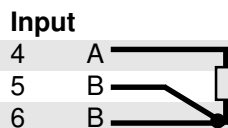

## LPN-R-X2 Terminations.

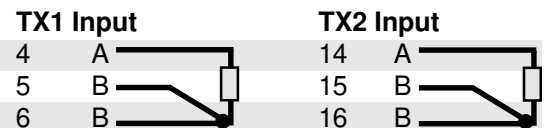

## Output

4	+mA Output
5	-mA Output
6	mV Test

## Output

1	+mA Output
2	-mA Output
3	mV Test

## TX1 Output

1	+mA Output
2	-mA Output
3	mV Test

## TX2 Output

11	+mA Output
12	-mA Output
13	mV Test

## LPN-R Programming.

The Zero and Span can be set within the following values, as shown in the tables.  
Refer to 'Location of LPN-R Jumpers' for positions of jumpers in the LPN-R.

Zero Jumper	Zero (C)	Zero (F)
A	From -105 to -55C	From -165 to 65F
B	From -55 to -5C	From -65 to 25F
C	From -5 to 45C	From 25 to 115F
D	From 45 to 100C	From 115 to 210F

Span Jumper	Span (C)	Span (F)
1	From 30 to 65C	From 55 to 115F
2	From 65 to 135C	From 115 to 245F
3	From 135 to 280C	From 245 to 505F
4	From 280 to 600C	From 505 to 1080F

E.g. 1. If a range of -50~50C is required.  
Zero = -50C. Jumper 'B'  
Span = 50--50 = 100C Jumper '2'

E.g. 2. If a range of 200~600F is required.  
Zero = 200F. Jumper 'D'  
Span = 600-200 = 400F Jumper '3'

Note 1. Once the range has been programmed calibrate the LPN-R using the Span and Zero Pots.  
Calibrate 0% = 4.00mA using the ZERO Pot. Calibrate 100% = 20.00mA using the SPAN Pot.  
Repeat Zero and Span calibrations until readings are correct. Check 50% = 12.00mA±0.016mA (±0.1% linearity)  
Note 2. If the range cannot be attained using jumpers shown in the tables above, try the next Jumper closest to the value you require.

### Upscale / Downscale Drive 'SB' Selection for Sensor Break.

Jumper BOTH positions marked 'DS' for DOWNSCALE, or Jumper BOTH positions marked 'US' for UPSCALE.

### Two Wire '2W'.

For 2 wire inputs, Jumper the position marked '2W'.

### LPN-R-D Enclosure Dimensions.

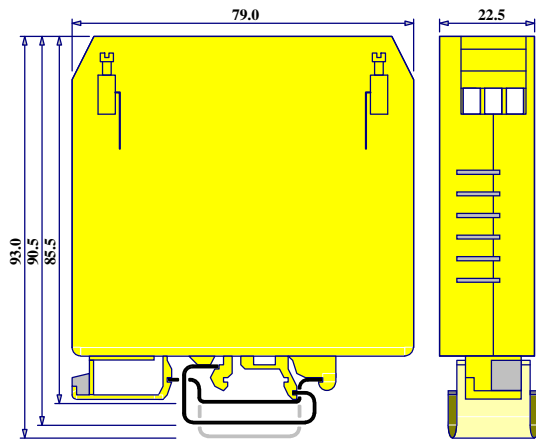

### LPN-R-E Enclosure Dimensions. (LPN-R-D Board Fitted)

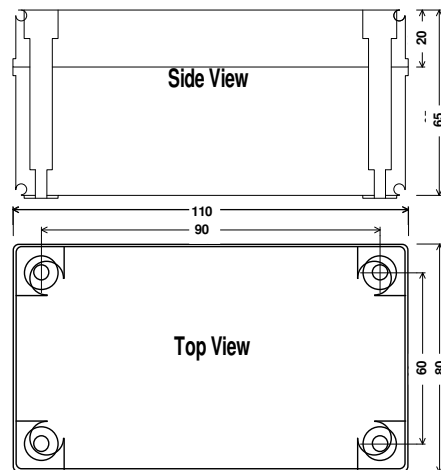

### LPN-R-X Enclosure Dimensions.

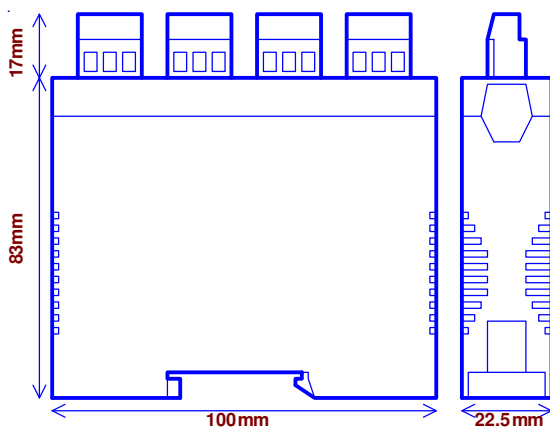

## Maximum Load Vs Power Supply.

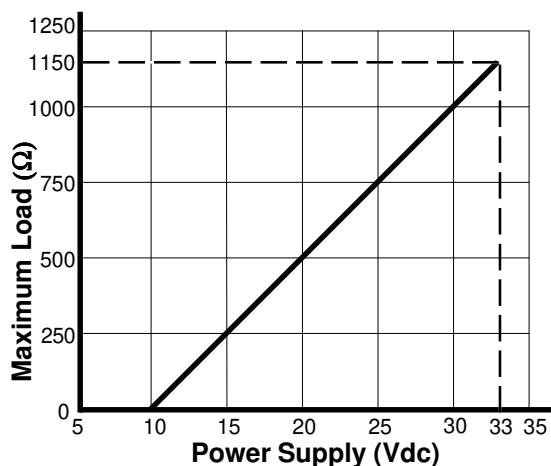

### The Proper Installation & Maintenance of LPN-R.

All power and signals must be de-energised before connecting any wiring, or altering any Jumpers.

#### MOUNTING.

- (1) Mount in a clean environment in an electrical cabinet on 35mm Symmetrical Mounting Rail.
- (2) Draft holes must have minimum free air space of 20mm. Foreign matter must not enter or block draft holes.
- (3) Do not subject to vibration or excess temperature or humidity variations.
- (4) Avoid mounting in cabinets with power control equipment.
- (5) To maintain compliance with the EMC Directives the LPN-R is to be mounted in a fully enclosed steel cabinet. The cabinet must be properly earthed, with appropriate input / output entry points, filtering, and cabling.

#### Cover Removal and Fitting.

To remove the LPN-R-X PCB to access jumpers and dip switches, push in the GREY BUTTONS at both ends of the enclosure TOP, and slide the PCB from the BASE of the enclosure. To reassemble slide the PCB back into the BASE until both GREY BUTTONS 'snap' into place. Ensure the TOP of the enclosure is flush with the BASE on all sides.

#### WIRING.

- (1) All cables should be good quality overall screened INSTRUMENTATION CABLE with the screen earthed at one end only.
- (2) Signal cables should be laid a minimum distance of 300mm from any power cables.
- (3) For 2 wire current loops Austral Standard Cables B5102ES is recommended. For three wire transmitters and RTD's Austral Standard Cables B5103ES is recommended.
- (4) It is recommended that you do not ground current loops and use power supplies with ungrounded outputs.
- (5) Lightning arrestors should be used when there is a danger from this source.
- (6) Refer to diagrams for connection information.

#### RTD'S.

- (1) Avoid locating the RTD where it will be in a direct flame.
- (2) Locate it where the average temperature will be measured. It should be representative of the mass.
- (3) Immerse the RTD far enough so that the measuring point is entirely in the temperature to be measured; nine to ten times the diameter of the protection tube is recommended. Heat that is conducted away from the measuring point causes a lower reading.

#### COMMISSIONING.

- (1) Once all the above conditions have been carried out and the wiring checked apply power to the LPN-R loop and allow five minutes for it to stabilize.
- (2) Due to differences in cable resistance in the RTD legs or errors within the RTD itself a small Zero error may occur (usually less than 0.5°C). To remove this error use a calibration standard RTD at the same immersion depth and adjust the ZERO Pot on the top of the LPN-R enclosure with a small screwdriver, until the two levels agree. (Clockwise to increase the output reading and anticlockwise to decrease the output reading)

#### MAINTENANCE.

- (1) Check RTD's in place - with a calibration RTD at the same immersion depth. Refer Commissioning.
- (2) Do it regularly - at least once every 6 months.
- (3) Replace defective protection tubes - even if they look good they may not be air or gas tight.
- (4) Check cables entering the RTD sensor head.
- (5) Keep rotary switches clean and free of oxidation of contact points.

**Intech** INSTRUMENTS LTD  
[www.intech.co.nz](http://www.intech.co.nz)  
Christchurch Ph: +64 3 343 0646  
Auckland Ph: 09 827 1930  
Email: [sales@intech.co.nz](mailto:sales@intech.co.nz)