

Ordering Information

XU Demo Kit



ITEM	CODE	DESCRIPTION
SERIES	XU-KIT	XU Demo Box - Which Includes: XU2HI, XU2HN, XU2, XU4 and XU-USB.

XU2HI & XU2HN, Head Mount Isolated & Non-Isolated Transmitters

ITEM	CODE	DESCRIPTION
SERIES	XU2HI- XU2HN-	Head Mount Transmitter Isolated Head Mount Transmitter Non-Isolated*
Type of Input	Pt100-	RTD Pt100 DIN (Options JIS & CN10)
	Pt1000-	RTD Pt1000 DIN (Options JIS & CN10)
	Tc □ -	Thermocouple Type; B, E, J, K, N, R, S, T
Measuring Range	-	State Measuring Range
Output Action on Sensor Fail	US	Upscale
	DS	Downscale

Note: Thermocouple Input is not available on the Non-Isolated XU2HN Transmitter.

XU-Spring-Kit For vibration areas or where wide ambient temperatures exist on the probe head.



XU2, 2 Wire Transmitter Loop Powered

ITEM	CODE	DESCRIPTION
SERIES	XU2-	Universal Input Transmitter
Type of Input	Pt100-	RTD Pt100 DIN (Options JIS & CN10)
	Pt1000-	RTD Pt1000 DIN (Options JIS & CN10)
	Tc □ -	Thermocouple Type; B, E, J, K, N, R, S, T
	mA-	mA Input impedance = 10Ω
	mV-	mV Input resistance = 300KΩ
	V-	V Input resistance = 300KΩ
	Pot 1- Pot 2-	Potentiometer Low = 0~2KΩ Potentiometer High = 0~1MΩ
Measuring Range	-	State Measuring Range
Output Action on Sensor Fail (for Temperature Input types only)	US	Upscale
	DS	Downscale

Ordering Examples:

- 1/ XU2 - Pt100 - 0~100C - DS XU2; RTD Pt100 DIN 0~100°C Input; Downscale; 4~20mA Output.
2/ XU2 - Tc K - 0~1200C - US XU2; Thermocouple Type K 0~1200°C Input; Upscale; 4~20mA Output.



XU4, 4 Wire Universal Transmitter

ITEM	CODE	DESCRIPTION
SERIES	XU4-	4 Wire Universal Input Transmitter
Type of Input	Pt100-	RTD Pt100 DIN (Options JIS & CN10)
	Pt1000-	RTD Pt1000 DIN (Options JIS & CN10)
	Tc □ -	Thermocouple Type; B, E, J, K, N, R, S, T
	mA-	mA Input impedance = 10Ω
	mV-	mV Input resistance = 300KΩ
	V-	V Input resistance = 300KΩ
	Pot 1- Pot 2-	Potentiometer Low = 1K~2KΩ Potentiometer High = 5K~1MΩ
Measuring Range	-	State Measuring Range
Type and Range of Output	-	State Current Output Range (e.g. 4~20mA) or State Voltage Output Range (e.g. 0~10V)
Output Action on Sensor Fail (for Temperature Input types only)	US	Upscale
	DS	Downscale

Ordering Examples:

- 1/ XU4 - Pt100 - 0~100C - 0~10V - DS XU4; RTD Pt100 DIN 0~100°C Input; Voltage: 0~10V Output; Downscale.
2/ XU4 - Tc K - 0~1200C - 4~20mA - US XU4; Thermocouple Type K 0~1200°C Input; 4~20mA Output; Upscale.

XU-USB USB Programming Key online:

Download free XU programming software via the link www.intech.co.nz/xu-usb



XU Transmitter Series

XU2

2 Wire Transmitter
Loop Powered



Isolated

XU2HI & XU2HN

In Head 2 wire
Loop Powered



Isolated & Non-Isolated

XU4

4 Wire Universal
Transmitter



Isolated

Power Supply:
20~265Vac &
21~265Vdc

Common Features

- Programmable via USB.
- No power supply or calibration required during programming.
- Input types:
 - RTD Pt100 and Pt1000
 - Thermocouple B, E, J, K, N, R, S, T**
 - mA, V, & mV *
 - Potentiometer *
 - 32 point curve fitter for mA, mV, V inputs.*
 - * Not available in the XU2HI / XU2HN.
 - ** Not available in the XU2HN.
- Input to Output Isolation 3750Vac. (Excluding XU2HN)
- High Accuracy 0.1%.
- Reverse Polarity Protected.
- Heartbeat Status LED. (XU2 / XU4 only)
- Case Temperature range -20°C to +80°C.
- Compact DIN Rail Mount Enclosure.
- Easy to Install.
- Low Cost.



★ Zero Adjust
Potentiometer
(XU2 / XU4 only)

★ No power supply or calibration
required during programming!

XU2, XU2HI & XU2HN (2 Wire) Universal Input

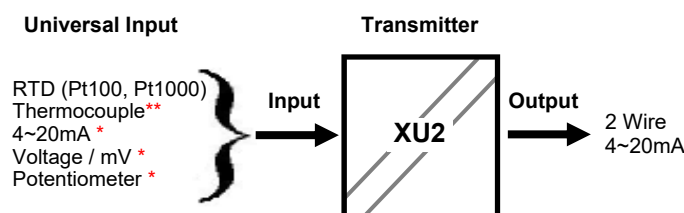

* Not available in the XU2HI / XU2HN.
** Not available in the XU2HN.

XU4 (4 Wire) Universal Input

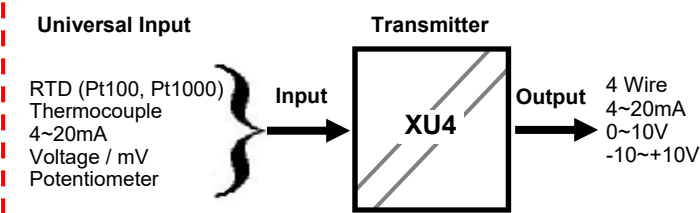

Product Liability. This information describes our products. It does not constitute guaranteed properties and is not intended to affirm the suitability of a product for a particular application. Due to ongoing research and development, designs, specifications, and documentation are subject to change without notification. Regrettably, omissions and exceptions cannot be completely ruled out. No liability will be accepted for errors, omissions or amendments to this specification. Technical data are always specified by their average values and are based on Standard Calibration Units at 25C, unless otherwise specified. Each product is subject to the 'Conditions of Sale'.
Warning: These products are not designed for use in, and should not be used for patient connected applications. In any critical installation an independent fail-safe back-up system must always be implemented

XU2, XU2HI & XU2HN Specifications

Output	2 wire 4~20mA / or 20~4mA - Loop Powered.
Power Supply	10.5~36Vdc.
Supply Voltage Sensitivity	<±0.005%/V FSO.
Output Load Resistance	700Ω @ 24Vdc. (50Ω/V Above 10.5Vdc.)
Maximum Output Current	Limited to <28mA.
EMC Emissions Compliance	EN 61326
EMC Immunity Compliance	EN 61326
Safety Compliance	EN 61010-1
Accurate to	<±0.03% FSO Typical.
Linearity & Repeatability	<±0.02% FSO Typical. (Unless Individual Specifications State Otherwise)
Ambient Drift	<±0.003%/C FSO Typical.
Noise Immunity	125dB CMRR Average. (2.0k Vdc Limit.)
R.F. Immunity	<1% Effect FSO Typical.
Signal Isolation Voltage	Between Input and Output 3750Vac for 1 min. (Excluding XU2HN)
Response Time	400msec Typical. (From 10 to 90% 300msec Typical.)
Sensor Fail	Low 3.8mA, High 21mA
Startup Time	3 seconds, 3.7mA output
Output calibrate via Pot	±0.5mA Zero offset adjust. (XU2 only)
Operating Temperature	-20~85°C (XU2HN: -20~65°C)
Storage Temperature	-20~100°C
Operating Humidity	5~85%RH Max. Non-Condensing.
Mounting	35mm Symmetrical Mounting Rail. In Head mount for XU2HI & XU2HN
Dimensions	XU2: H=79, W=20, D=68mm. / XU2HI & XU2HN: H=44, W=44, D=23mm.

XU4 Specifications

Output	4 wire
- Voltage	Field Programmable from 0V~10V, 10V~0V, +10V to (-10V), -10V to +10V
- Current	Field Programmable from 4~20mA, 0~20mA, 20~4mA & 20~0mA
Universal P/S:	20~265Vac and 21~265Vdc
- Circuit Sensitivity	<±0.001%/V FSO Typical.
EMC Emissions Compliance	EN 61326
EMC Immunity Compliance	EN 61326
Safety Compliance	EN 61010-1
Accurate to	<±0.03% FSO Typical.
Linearity & Repeatability	<±0.02% FSO Typical. (Unless Individual Specifications State Otherwise.)
Ambient Drift	<±0.003%/C FSO Typical.
Noise Immunity	125dB CMRR Average. (2.0kVdc Limit.)
R.F. Immunity	<1% Effect FSO Typical.
Signal Isolation Voltage	Between Input and Output 3750Vac for 1 min.
Response Time	400msec Typical. (From 10 to 90% 300msec Typical)
Output calibrate via Pot	±0.5mA Zero offset adjust
Error Detection	LED indication for sensor errors.
Operating Temperature	-20~85°C.
Storage Temperature	-20~100°C.
Operating Humidity	5~85%RH Max. Non-Condensing.
Mounting	35mm Symmetrical Mounting Rail.
Dimensions	H=79, W=30, D=68mm.

Terminal Connections

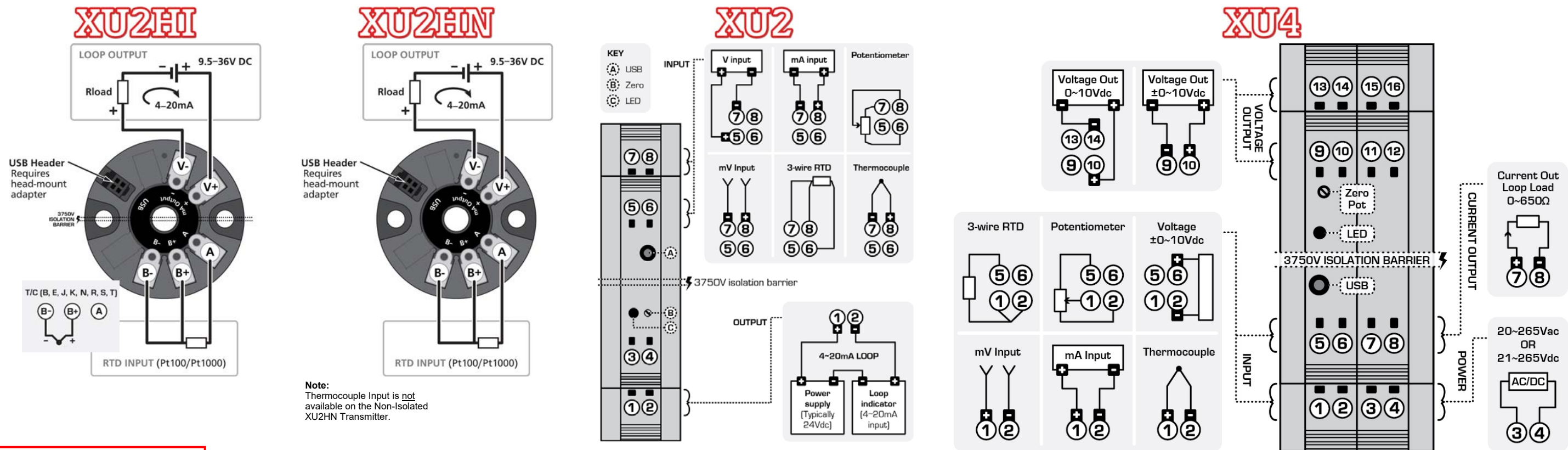

Common Specifications

Thermocouple		RTD		Voltage/Current Input		Potentiometer	
Thermocouple Input	Types B, E, J, K, N, R, S, T	RTD Input	Pt100 or Pt1000 DIN 3 Wire Type. (2 Wire can be used with offset Calibration)	Voltage Input		Potentiometer Input	3 Wire Potentiometer.
- USB Programmable Zero	From 0 to ±99% of the Span.	- Sensor Current	0.15mA Nominal	- USB Programmable Zero	From 0 to ±99% of the Span.	- Excitation Voltage	1.2Vdc.
- USB Programmable Span	Within Thermocouple Type Limits.	- Lead Wire Resistance	Pt100: 10Ω/Wire Max. Pt1000: 5Ω/Wire Max. 0.02%FSO Offset error per Ω of lead resistance.	- USB Programmable Span	From ±100mVdc to ±10Vdc and Bipolar.	- Potentiometer Resistance	Low Range 1KΩ~2KΩ.
- Input Impedance	1MΩ Minimum.	- USB Programmable Zero	From 0 to ±99% of the Span.	- Minimum Input Resistance	300kΩ.	- Maximum Pot Resistance	High Range 5KΩ~1MΩ.
- T/C Lead Resistance	100Ω Maximum.	- USB Programmable Span	From -200C to 850°C	- mV Maximum Over-range	3Vdc Continuous.	- USB Programmable Zero	From 0 to 90% of the Span.
- Cold Junction Comp. Range	-20~90°C.	- Sensor Break Output Drive	Funct High Upscale. Funct Low Downscale	- V Maximum Over-range	60Vdc Continuous	- Field Programmable Span	From 0.1 to 100%.
- Accuracy - E,J,K,N,T	<±1°C, temp drift <±0.05°C	- Linearity (Pt100)	0.02% FSO for SPAN Inputs ≤200°C. 0.1% FSO for SPAN Inputs ≤850°C.	- Linearity Repeatability	<±0.02% FSO Typical	- Linearity and Repeatability	<±0.02% FSO Typical
- Accuracy - B, R, S	<±2°C, temp drift <±0.2°C	- Linearity (Pt1000)	0.02% FSO for SPAN Inputs ≤200°C. 0.2% FSO for SPAN Inputs ≤520°C.	Current Input			
- CJC error	<±1°C	<i>Other Types of RTD Available.</i>	JIS and CN10	- USB Programmable Zero	From 0 to ±99% of the Span.		
- Output Linear with temperature				- Field Programmable Span	From 1μA to 24mAdc. Standard range = 4~20mA		
- Sensor Break Output Drive	Upscale Standard. Downscale selectable.			- Minimum Recommended Span	0~1mA (gives 1000 steps on output)		
				- Input Resistance	10Ω.		
				- Maximum Over-range	50mAdc Continuous.		
				- Linearity and Repeatability	<±0.02% FSO Typical		