

# PI-S Programmable Isolating Dual Set Point Alarm Unit.

Programmable Isolating DC Voltage or DC Current Input Dual Setpoint Alarm Unit.

## Features.

- Field Programmable Input Ranges.
- Isolated Input to Output 1.6kV.
- High Accuracy.
- Universal AC/DC Power Supply.
- 0~100% Alarm Set Point Range.
- Dual Relay or SSR Drive Outputs.
- LED Indication of Relay Status.
- N.O. / N.C. Selectable Contacts.
- 0.2~30sec Adjustable Delay.
- High, Low, Window & Differential Selectable Alarms.



Other PI- models include:  
 PI-B Bridge / Strain gauge;  
 PI-D DC; mA, mV, V.  
 PI-F Frequency;  
 PI-K Resistance;  
 PI-M Maths Computing;  
 PI-N RTD Differential Pt100;  
 PI-P Potentiometer;  
 PI-R RTD Pt100;  
 PI-S Relay Dual Setpoint;  
 PI-T Thermocouple.

## Ordering Information.

PI-S-X Standard Calibration. Input: 4~20mA; Output: Relay A- High Alarm; Setpoint 80%; Relay B- Low Alarm; Setpoint 20%; Relay Contacts N.O.; No Time Delay; High Voltage Power Supply.

PI-S -  -  -  -   
 IR AR CO PS

Note: (i) N.O. = Normally Open, N.C. = Normally Closed.  
 (ii) Differential is also known as 'PUMP ON / OFF'.

Input Ranges		Alarm Relay Action			Contact Options				
Range	IR	Relay A	Relay B	AR	Relay		SSR		CO
					A	B	A	B	
0~5V	1	High Alarm	High Alarm	A	N.O.	N.O.			1
1~5V	2	High Alarm	Low Alarm	B	N.O.	N.C			2
0~10V	3	High Alarm	Slave Without Delay	C	N.C.	N.O			3
2~10V	4	High Alarm	Slave With Delay	D	N.C.	N.C			4
0~10mA	5	High Alarm	Inverted Slave With Delay	E			N.O.	N.O.	5
2~10mA	6	Low Alarm	High Alarm	F			N.O.	N.C	6
0~20mA	7	Low Alarm	Low Alarm	G			N.C.	N.O	7
4~20mA	8	Low Alarm	Slave Without Delay	H			N.C.	N.C	8
0~50mA	9	Low Alarm	Slave With Delay	I					
10~50mA	10	Low Alarm	Inverted Slave With Delay	J					
		Window Comparator	High Alarm	K					
		Window Comparator	Low Alarm	L					
		Window Comparator	Slave Without Delay	M					
		Window Comparator	Slave With Delay	N					
		Window Comparator	Inverted Slave With Delay	O					
		Differential	High Alarm	P					
		Differential	Low Alarm	Q					
		Differential	Slave Without Delay	R					
		Differential	Slave With Delay	S					
Special Input Range	Z	Differential	Inverted Slave With Delay	T					
<b>Power Supply</b>									<b>PS</b>
High Voltage Power Supply: 85~264Vac/dc									H
Mid Voltage Power Supply: 22~85Vac/dc									M

Note: Power supply H is field selectable for M, and M for H.

## Ordering Examples:

- 1/ PI-S-3-A-4-H 0~10V Input; High Alarms; N.C. Contacts; High Voltage Power Supply.
- 2/ PI-S-8-M-1-H 4~20mA Input; Window With Slave; N.O. Contacts; High Voltage Power Supply.

## Quality Assurance Programme.

The modern technology and strict procedures of the ISO9001 Quality Assurance Programme applied during design, development, production and final inspection grant the long term reliability of the instrument.

# PI-S Rev2 Specifications.

Input	-Voltage	Field Programmable 0~5, 1~5, 0~10 & 2~10Vdc. Minimum Input Resistance = 200kΩ.
	- Current	Maximum Over Range = 200Vdc Continuous. Field Programmable 0~10, 2~10, 0~20, 4~20, 0~50 & 10~50mA. Maximum Input Resistance 20mA Ranges = 50Ω, Other mA Ranges = 100Ω. Maximum Over Range = 80mAdc Continuous.
Output	-Both Relays	Field Selectable, N.O. or N.C. Field Selectable; Active on High or Low; Window Alarm; or Differential Alarm.
	-SSR Drive	12V @ 20mA max.
Alarm Setting Range		0~100% of Input Signal: 0~99% in 1% Increments, Using Two Ten-position Setpoint Switches and ±1% Using the Fine Adjustment Trimptot.
Alarm Hysteresis		1% FSO Typical.
Time Delay		0.2~30sec Nominal, Adjustable by a Single Turn Trimptot.
LED Indication		Operates When Alarms are Active.
Relay Outputs.		Action; SPST. Contact Material; Silver Alloy.
	Maximum Rating	No. of Operations
	250Vac, 2A	2x10 <sup>5</sup> @ 1A 250Vac Resistive
	125Vac, 2A	
	110Vdc, 0.3A	
	30Vdc, 2A	
	1/6hp, 250Vac	
	1/10hp, 125Vac	
Power	-H	85~264Vac/dc; 50/60Hz; 5VA.
	-M	22~85Vac/dc; 50/60Hz; 5VA.
	-Circuit Sensitivity	<±0.001%/V FSO Typical.
Accurate to:		<±0.1% FSO Typical.
Linearity & Repeatability		<±0.1% FSO Typical.
Ambient Drift		<±0.01%/C FSO Typical.
Noise Immunity		125dB CMRR Average. (1600Vdc Limit).
EMC Compliances		Emissions EN 55022-A. Immunity EN 50082-1, <1% Effect FSO Typical.
Safety Compliance		EN 60950
Mains Isolation		250Vac.
Isolation Test Voltages		Mains to Input/Outputs 3kVac 50Hz for 1min; Input to Outputs 3kVac for 1min.
Operating Temperature & Humidity		0~60C. (Storage Temp. -20~80C.) 5~85% RH Max. Non-Condensing.
Dimensions and Mounting		L=80, W=50, H=120mm. Mounts on 35mm Symmetrical Mounting Rail.

**Product Liability.** This information describes our products. It does not constitute guaranteed properties and is not intended to affirm the suitability of a product for a particular application. Due to ongoing research and development, designs, specifications, and documentation are subject to change without notification. Regrettably, omissions and exceptions cannot be completely ruled out. No liability will be accepted for errors, omissions or amendments to this specification. Technical data are always specified by their average values and are based on Standard Calibration Units at 25C, unless otherwise specified. Each product is subject to the 'Conditions of Sale'.

**Warning:** These products are not designed for use in, and should not be used for patient connected applications. In any critical installation an independent fail-safe back-up system must always be implemented.

## Examples of Input Connection.

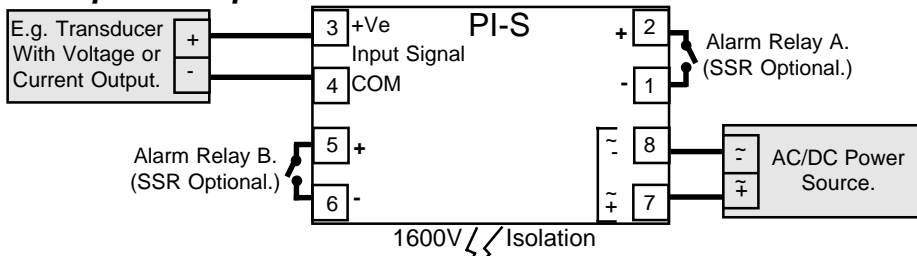

## Terminations

Alarm A:	1	RELAY
	2	A
Input	3	+Ve SIGNAL
	4	COM
Alarm B:	5	RELAY
	6	B
P/S	7	Neutral/+DC
	8	Phase/-DC

## Plan View of PI-S Adjustments.

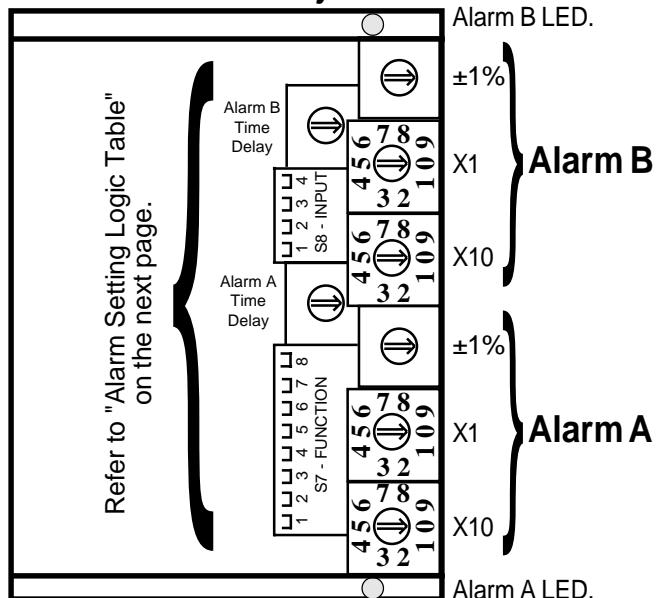

## PI-S Dimensions and Mouning.

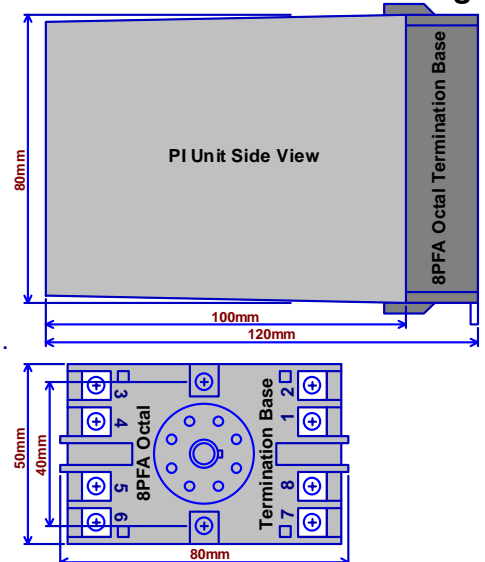

### Setting Alarm Setpoints.

DIP switches and Pots are accessed by removing the small rectangular lid on the top of the PI-S enclosure

Example. To set a 28% alarm setpoint:

Set X10 to 2 (ie.20%)

Set X1 to 8 (ie. 8%)

=> Total = 28%

If finer than 1% alarm setpoint resolution is required, use the FINE Pot shown in the 'Plan View of PI-S Adjustments'. Adjust the Pot clockwise to increase the setpoint setting, and anti-clockwise to decrease the setpoint setting.

\*Refer to page 'Alarm Action Notes' for more information.

### Time Delay Settings.

Fully clockwise = 30sec (maximum delay).

Fully anti-clockwise = 0.2sec (minimum delay).

Time delay is only active going INTO the alarm state.

There is no time delay coming out of an alarm state.

NOTE: The table below DOES NOT show time delays.

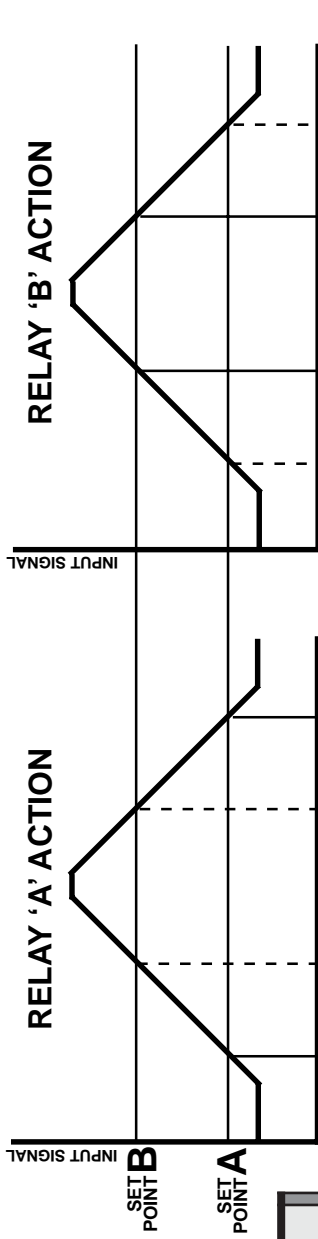

### Alarm Setting Logic Table.

Alarm Relay Action		S7 - Function							
Alarm Relay A	Alarm Relay B	1	2	3	4	5	6	7	8
High Alarm	High Alarm	1	1	0	1	1	0	1	0
High Alarm	Low Alarm	1	0	0	1	1	0	1	0
High Alarm	Slave Without Delay	1	0	0	0	1	1	0	1
High Alarm	Slave With Delay	1	1	0	0	1	0	1	0
High Alarm	Inverted Slave With Delay	1	0	0	0	1	0	1	0
Low Alarm	High Alarm	0	1	0	1	1	0	1	0
Low Alarm	Low Alarm	0	0	0	1	1	0	1	0
Low Alarm	Slave Without Delay	0	0	0	0	1	1	0	1
Low Alarm	Slave With Delay	0	1	0	0	1	0	1	0
Low Alarm	Inverted Slave With Delay	0	0	0	0	1	0	1	0
Window Comparator	High Alarm	0	1	1	1	1	1	0	0
Window Comparator	Low Alarm	0	0	1	1	1	0	1	0
Window Comparator	Slave Without Delay	0	0	1	0	1	0	1	1
Window Comparator	Slave With Delay	0	1	1	0	1	0	1	0
Window Comparator	Inverted Slave With Delay	0	0	1	0	1	0	1	0
Differential	High Alarm	0	1	1	1	1	0	0	0
Differential	Low Alarm	0	0	1	1	1	0	0	0
Differential	Slave Without Delay	0	0	1	0	0	1	0	1
Differential	Slave With Delay	0	1	1	0	0	0	0	0
Differential	Inverted Slave With Delay	0	0	1	0	0	1	0	0

## PI-S H1 Power Supply Jumper Settings.



**WARNING: High Voltages Maybe Present.**  
Only adjust jumper with power disconnected.

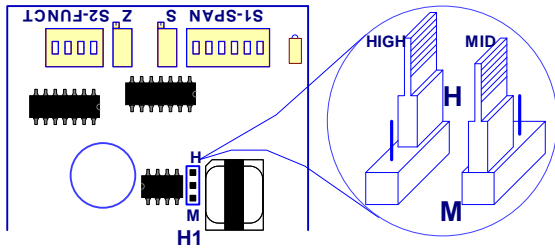

Power Supply Jumper Settings	
H1	Power Supply Voltage Range
H	Link for High: 85~264Vac/dc
M	Link for Mid: 22~85Vac/dc

Notes:

- 1/ H1 is approx 4cm (1½") behind the 'S' trimpot.
- 2/ Exceeding voltage ranges may damage the unit.
- 3/ Ensure the enclosure label is correctly labelled for the jumper position.
- 4/ Adjust H1 jumper with a pair of needle nose pliers.

## PI-S Input Programming Table.

		S8-INPUT			
		1	2	3	4
Voltage Input	0~5V	0	0	1	0
	1~5V	0	0	1	1
	0~10V	0	0	0	0
	2~10V	0	0	0	1
Current Input	0~10mA	0	1	0	0
	2~10mA	0	1	0	1
	0~20mA	1	1	0	0
	4~20mA	1	1	0	1
	0~50mA	1	0	1	0
	10~50mA	1	0	1	1

## Alarm Action Notes.

- (i) **B** relay is always the slave, copying the operation of **A** relay.
- (ii) 'Slave Without Delay' means **A** & **B** relays switch simultaneous.
- (iii) 'Slave With Delay' means **B** relay uses the 'B Time Delay'.
- (iv) For Window Comparator and Differential alarms, **A** & **B** setpoints are interchangeable, but use the 'A Time Delay'.
- (v) The PI-S can be configured as a single setpoint change over alarm unit when using alarm relay actions 'C', 'H', 'M', or 'R'.

- Make **A** relay N.O., and **B** relay N.C.
- Output terminal 2 & 5 must be externally jumpered.
- Output terminal 1 becomes N.O.
- Output terminal 6 becomes N.C.
- Output terminal 2 & 5 become common.

**NOTE:** In this change over mode, it is possible for both alarm relays to be in the same state, for a maximum of 100msec.

## The Proper Installation & Maintenance of PI-S.

Note. All power and signals must be de-energised before connecting any wiring, altering any jumpers or DIP switches, or inserting or removing the PI unit from it's base.

### MOUNTING.

- (1) Mount in a clean environment in an electrical cabinet on DIN or EN mounting rail.
- (2) Draft holes must have minimum free air space of 20mm. Foreign matter must not enter or block draft holes.
- (3) Do not subject to vibration or excess temperature or humidity variations.
- (4) Avoid mounting in cabinets with power control equipment.
- (5) To maintain compliance with the EMC Directives the LPI-B is to be mounted in a fully enclosed steel cabinet. The cabinet must be properly earthed, with appropriate input / output entry points and cabling.

### WIRING.

- (1) A readily accessible disconnect device and a 1A, 250Vac overcurrent device, must be in the power supply wiring.
- (1) All cables should be good quality overall screened INSTRUMENTATION CABLE with the screen earthed at one end only.
- (2) Signal Cables should be laid a minimum distance of 300mm from any power cables.
- (3) For 2 wire current loops and 2 wire voltage signals or 2 wire current signals, Austral Standard Cables B5102ES is recommended. For 3 wire transmitters Austral Standard Cables B5103ES is recommended.
- (4) It is recommended that you do not ground current loops and use power supplies with ungrounded outputs.
- (5) Lightning arrestors should be used when there is a danger from this source.
- (6) Refer to diagrams for connection information.

### COMMISSIONING.

- (1) Ensure that the unit has been set up for the correct:
  - {i} alarm relay options- alarm trigger points, time delays, N.O. / N.C.;
  - {ii} contact options: and high / low, window, differential, or slave alarm action.
 as per calibration information.
- (2) Once all the above conditions have been carried out and the wiring checked, apply the power to the PI-S, and allow five minutes for the unit to stabilize.
- (3) Check the alarm trigger point by varying or simulating the input signal to the PI-S. Check that the unit triggers at the correct setting and that the time delay is correct.

**CAUTION:** Before triggering the alarm unit, ensure that this will not cause any undesirable effects. It may be necessary to isolate the alarm relay action before checking the settings.

### MAINTENANCE.

- (1) Repeat (3) of Commissioning.
- (2) Do it regularly - at least once every 12 months.

**Intech**  
Instruments

[www.intech.co.nz](http://www.intech.co.nz)

Christchurch Ph: +64 3 343 0646  
Auckland Ph: 09 827 1930  
Email: [sales@intech.co.nz](mailto:sales@intech.co.nz)