

LPN-LUX

(Replaces TWN-LUX.)

Light Intensity Transmitter.

Light Intensity (LUX)
Sensor and 2 Wire
Output Transmitter.

Description.

The LPN-LUX incorporates an integrated light sensor within an industrial IP66 rated sealed enclosure and is especially designed for high precision linear applications. The sensor has a flat glass window with a built in colour correction filter, giving an approximation to the spectral response in the human eye.

Features.

- Various Lux Ranges Available.
- 2 wire 4~20mA Output (Loop Powered).
- High Accuracy.
- IP66 Enclosure.
- Low Cost.
- Easy to Install.
- Reverse Polarity Protection.



Ordering Information.

- **LPN-LUX** - Standard Calibration: 0~1000lux Nominal.
- - Special Calibration Ranges available: 0~100, 0~500, 0~5000, 0~10000lux.

Specifications.

Input		0~1000lux - Standard Calibration.
Output	Current	2 wire 4~20mA (Loop Powered).
	Load Resistance	600Ω @ 24Vdc.
Power Supply		8~33Vdc (Loop Powered).
Temperature Coefficient		0.15% per 1°C.
Operating Temperature		0~60°C (Storage Temp. -20~80°C).
Operating Humidity		5~85% RH Max. Non-Condensing.
Analogue/Digital Converter		12 Bit.
EMC Compliances		Emissions EN 55022-A. Immunity EN 50082-1.
Safety Compliances		EN 60950.
Cable Length		2m.
Enclosure	Type	Polycarbonate.
	Ratings	IP66 rated, RoHS Compliant, UL 94 HB Flammability Rating.
	Dimensions	L=64mm, W=58mm, H=35mm (Length including mounting flanges = 94mm).

LPN-LUX Dimensions.

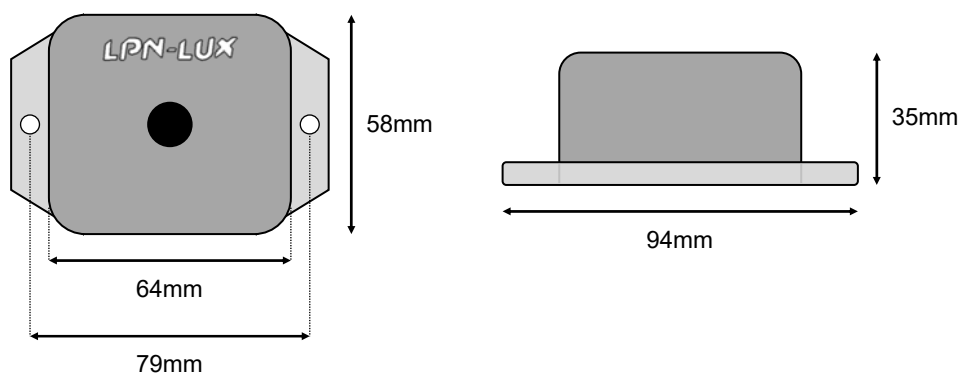

Product Liability. This information describes our products. It does not constitute guaranteed properties and is not intended to affirm the suitability of a product for a particular application. Due to ongoing research and development, designs, specifications, and documentation are subject to change without notification. Regrettably, omissions and exceptions cannot be completely ruled out. No liability will be accepted for errors, omissions or amendments to this specification. Technical data are always specified by their average values and are based on Standard Calibration Units at 25C, unless otherwise specified. Each product is subject to the 'Conditions of Sale'.

Warning: These products are not designed for use in, and should not be used for patient connected applications. In any critical installation an independent fail-safe back-up system must always be implemented.

Connection Diagram - 4~20mA Loop Powered.

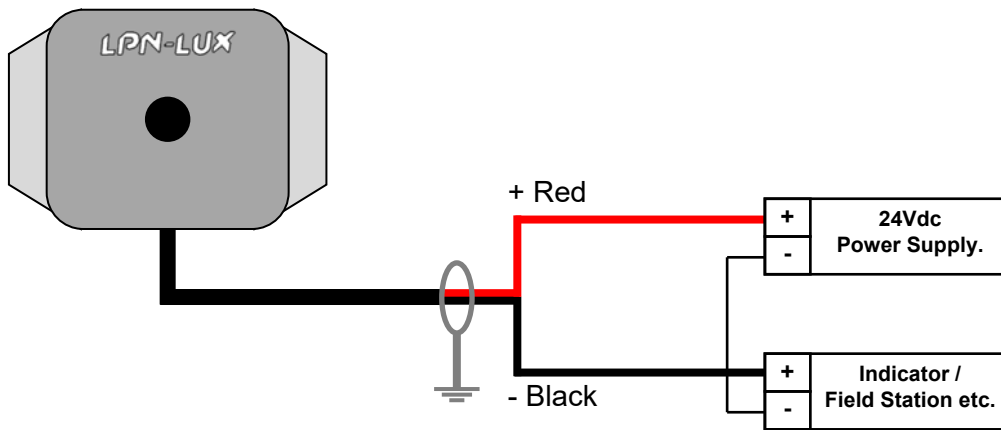

Maximum Load Vs Power Supply.

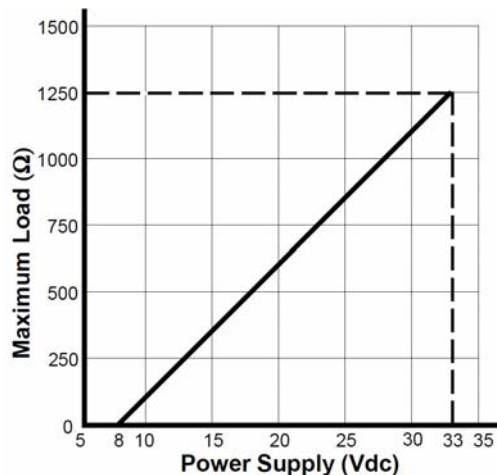

The Proper Installation & Maintenance of LPN-LUX.

MOUNTING.

- (1) Mount in a clean environment away from power control equipment. Be mindful of positioning the light sensor; positioned in the centre of the enclosure, so that the desired level of illumination reaches the sensor. **Do Not mount the sensor in direct light or sunlight** - measure reflected light. e.g. mount on the ceiling, facing the floor, to measure the light level of the room.
- (2) Do not subject to vibration or excess temperature or humidity variations.

WIRING.

- (1) All cables should be good quality overall screened INSTRUMENTATION CABLE with the screen earthed at one end only.
- (2) Signal cables should be laid a minimum distance of 300mm from any power cables.
- (3) It is recommended that you use power supplies with ungrounded outputs and that you do not ground current loops.
- (4) Lightning arrestors should be used when there is a danger from this source.
- (5) To ensure IP66 rating is maintained, make sure all closures are properly sealed; including the wire gland.

COMMISSIONING.

- (1) Once all the above conditions have been carried out and the wiring checked, apply power to the LPN-LUX and allow five minutes for it to stabilise.

MAINTENANCE.

- (1) For cleaning the LPN-LUX sensor, use a wet cloth and ensure all traces of dirt are removed. Do not use any cleaning agents. Do it regularly - at least once every 6 months.

Intech
Instruments

www.intech.co.nz

Christchurch Ph: +64 3 343 0646

Auckland Ph: 09 827 1930

Email: sales@intech.co.nz