

# Intech Micro 2300-RTD6 analogue input station MODBUS RTU slave application supplementary manual.

## **MODBUS supplementary manual to the 2300-RTD6 Installation Guide.**

The 2300 series stations are designed to connect as slaves to MODBUS RTU masters such as PC's or PLC's to offer an economical I/O solution.

### **Intech Micro 2300 Series I/O stations:**

- 2300-A8II** - 8 Isolated Current Inputs.
- 2300-A8VI** - 8 Isolated Voltage Inputs.
- 2300-Tc8** - 8 Isolated Thermocouple Inputs.
- 2300-RTD6** - 6 RTD Inputs.
- 2300-MULTI** - 2 RTD, 2 AI, 1 AO, 4 DI, 2 DO.
- 2300-D16** - 16 Digital Inputs.
- 2300-RO4** - 4 Relay Outputs.
- 2300-AO8I** - 8 Current Outputs.
- 2300-NET** - Isolated Ethernet TCP/IP to RS485.



### **Intech Micro 2300 Series - Connection Examples.**

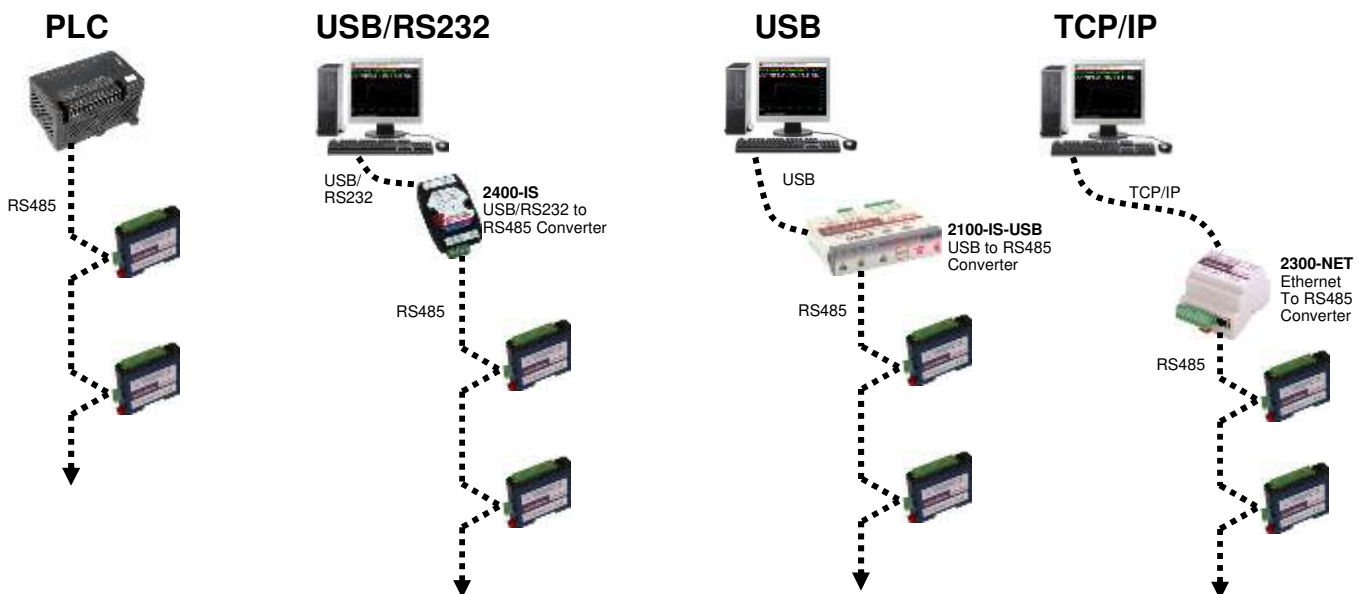

## 2300-RTD6 Specifications.

<b>RTD Inputs:</b>	-Input Points	6
	-RTD Configuration	2 or 3 Wire
	-Resolution	0.1°C
	-Drift	100ppm/°C Typ.
	-Line resistance effect	< 0.1°C balanced
	-Max. Line resistance	100ohms
	-Isolation	1500Vrms between field and logic

<b>RTD Type:</b>				
	-Number	Type	Range	Accuracy
	-1	Pt100	-200 to 850°C	± 0.3°C, IEC 751:1983
	-2	Ni120	-80 to 320°C	± 0.3°C
	-3	Pt1000	-200 to 850°C	± 0.3°C
	-4	Ni1000-DIN	-200 to 850°C	± 0.3°C
	-5	Ni1000-Landys&Gyr	-200 to 850°C	± 0.3°C
	-6	Ohms	10~400 ohms	± 0.05%
	-7	Ohms	100~4000 ohms	± 0.05%

<b>Connectors:</b>	-Logic Power and Comms	4 Pin plug-in connector on side of station
	-Inputs	18 Way screw plug-in connector on top of station

<b>Comms:</b>	-Protocols	RS485, Modbus RTU
	-Baud Rate	2400, 4800, 9600, 19200, 38400, 57600, 115200
	-Format	Parity: 0 = none, 1 = even, 2 = odd Stop Bits: 1 = 1 stop bit, 2 = 2 stop bits

<b>Power Supply:</b>	-Logic Supply Voltage	12~24Vdc
	-Logic Supply Current	87mA @ 12V / 45mA @ 24V

<b>Safety and EMC Compliances:</b>	
EMC Compliance	89/336/EEC and Low Voltage Equipment Directive 73/23/EEC
Safety Compliance	IEC 950

<b>General Specifications:</b> (Unless otherwise stated in other input specifications).		
Operating Temperature	-10~50°C	
Storage Temperature	-40~85°C	
Operating Humidity	Up to 95% non condensing	
Housing	-Dimensions	L=97.5, W=22.6, H=109mm
	-Mounting	35mm Symmetrical Mounting Rail.

Note 1. Contact INTECH INSTRUMENTS for more detailed programming information.

**Product Liability.** This information describes our products. It does not constitute guaranteed properties and is not intended to affirm the suitability of a product for a particular application. Due to ongoing research and development, designs, specifications, and documentation are subject to change without notification. Regrettably, omissions and exceptions cannot be completely ruled out. No liability will be accepted for errors, omissions or amendments to this specification. Technical data are always specified by their average values and are based on Standard Calibration Units at 25C, unless otherwise specified. Each product is subject to the 'Conditions of Sale'.

**Warning: These products are not designed for use in, and should not be used for patient connected applications. In any critical installation an independent fail-safe back-up system must always be implemented.**

## Modbus Register Types.

There are 4 types of variables which can be accessed from the station. Each station has one or more of these data variables.

Type	Start Address	Variable	Access
1	00001	Digital Outputs	Read & Write
2	10001	Digital Inputs	Read Only
3	30001	Input registers (Analog)	Read Only
4	40001	Output registers (Analog)	Read & Write (Holding type)

**Note:** The Modbus message length must be limited to 100 consecutive read or write registers. If more registers are required then a new poll group must be added for the next xxx registers.

The 2300-RTD6 station is a 6 RTD input station. The station can accommodate either 2 or 3 wire RTD sensors. The RTD inputs are isolated from the logic.

The RTD resistance is read by the station circuitry, linearised and converted to degrees Centigrade. No ranging is required as the station covers the full range of the RTD as indicated in the RTD table. The value that is read from the Modbus register is the actual temperature in degrees centigrade to 0.1°C resolution. ie: a value of 3451 corresponds to a temperature of 345.1°C.

The RTD type is setup by writing a value to the RTD Type register. The value is obtained from the table below. For example to select a Pt100 RTD, the value "1" must be written to the RTD Type register. All 6 RTD inputs adopt the same RTD type.

The DIP switch 9 is used to select upscale or downscale burnout for break detection. A value of 32768 is used to indicate upscale burnout and a value of -32767 is used to indicate downscale burnout.

**Note:** As there is no inter-channel isolation, isolated RTD's must be used in order to prevent ground loops and reading errors.

### **Communications Settings.**

The data in the station is stored in 16 bit registers. These registers are accessed over the network using the MODBUS RTU communication protocol.

#### **Communications Settings with DIP Switch 10 OFF (IOStudio Mode)**

BAUD RATE        9600  
 DATA BITS        8  
 PARITY            NONE  
 STOP BITS        1

#### **Communications Settings with DIP Switch 10 ON (Programmed Baud Rate, MicroScan SCADA Factory Default)**

BAUD RATE        2400, 4800, 9600, 19200, 38400, 57600, 115200  
 DATA BITS        8  
 PARITY            None, Even, Odd  
 STOP BITS        1, 2

Note: To change these settings, download the free **IOStudio 2300 Series MODBUS Configuration** software via the link from the Intech website: [www.intech.co.nz/2300](http://www.intech.co.nz/2300)

During this mode, DIP Switch 10 should be turned OFF so that the PC can communicate with the 2300 station using the IOStudio Mode communications settings. Once the Communications Settings are programmed, power down the 2300 station and change DIP Switch 10 to the ON position. Restore the power to the 2300 station and the configured Communications Settings will be ready for use.

**Warning:** Only program ONE 2300 station at a time!

### **Communications Settings Registers.**

40121	Baud Rate	2400	11520	R/W	2400, 4800, 9600, 19200, 38400, 57600, 115200
40122	Parity	0	2	R/W	0 = none, 1 = even, 2 = odd
40123	Stop Bits	1	2	R/W	1 = 1 stop bit, 2 = 2 stop bits
40124	Reply Delay	0	65535	R/W	(x10ms)

### Baud Rate Register (40121)

The baud rate value is programmed directly into the baud rate register. The only exception is the 115200 baud rate where the value 11520 is used.

### Parity Register (40122)

The parity can be set to none by writing a 0 to the parity register, set to even by writing a 1 to the parity Register or set to odd by writing a 2 to the parity register.

### Stop Bits Register (40123)

The number of stop bits can be set to 1 by writing a 1 to the stop bits register or set to 2 by writing a 2 to the stop bits Register.

### Reply Delay Register (40124)

The reply delay is a time delay between the Modbus message received to the reply being sent. In some applications where a modem or radio is used in the RS485 network, it may be necessary to add a reply delay due to turn around delays in the equipment.

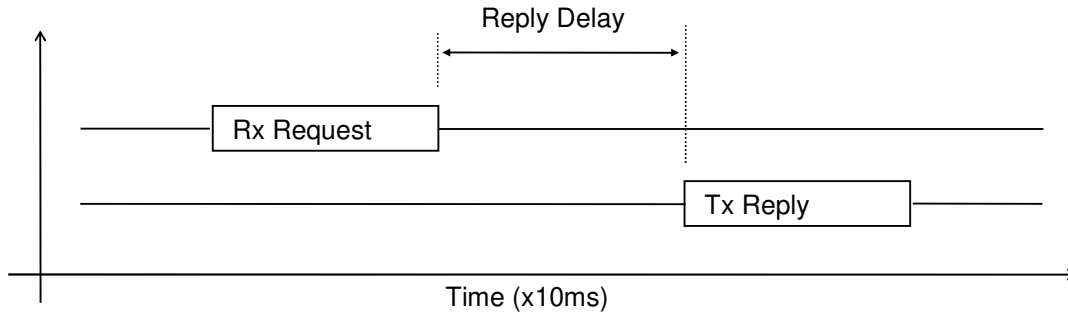

### Status Indicators.

- Power:** Flashes to indicate the CPU is running.
- RS485 Rx:** Flashes to indicate the unit has received a valid Modbus message.
- RS485 Tx:** Flashes to indicate the unit has sent a Modbus message.
- Input Status:** "ON" when the RTD is open circuit.  
"OFF" when the RTD is connected.

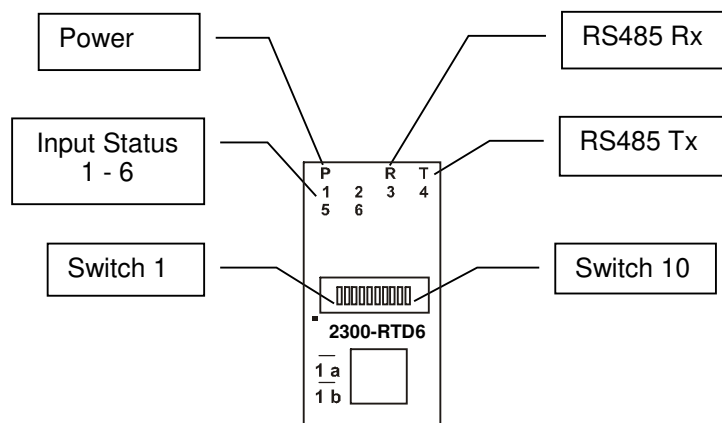

### Power and RS485 Comms Wiring.

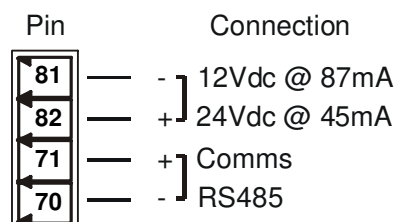

**Warning:** If the power/communication connections are reversed, the remote station may become faulty.

## Wiring.

The following diagram shows how the inputs are connected to a 2 and 3 wire RTD.

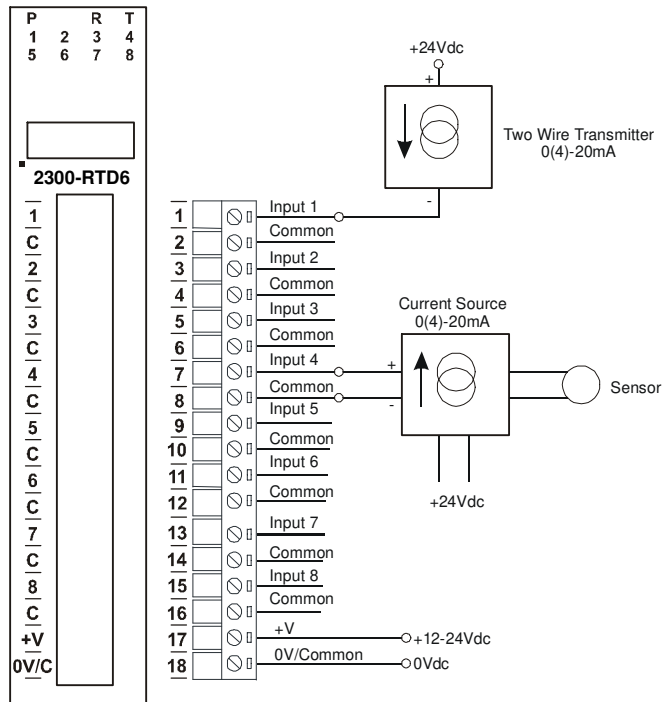

## Dip Switch Settings.

DIP SWITCH	FUNCTION	DESCRIPTION
1	STATION ID	+1 Station ID's from 0 to 127 are set up using switches 1 to 7
2	STATION ID	+2 "
3	STATION ID	+4 "
4	STATION ID	+8 "
5	STATION ID	+16 "
6	STATION ID	+32 "
7	STATION ID	+64 "
8	-	Not used
9	RTD BREAK	RTD break. When switched off the RTD value will loaded with -32767 when the RTD is faulty. When switched on the RTD value will be loaded with 32768.
10	BAUD RATE	Selects 9600 in OFF position (IOstudio Mode) or Programmed Baud Rate in ON position (MicroScan SCADA Factory Default) See Page 3 'Communications Settings.' for more information.

Note: See Installation Guide for the Station ID Table (Dip Switch Settings).

## Data Registers.

Modbus Address	Register Name	Low Limit	High Limit	Access	Description
30001	S/W Version / Module Type	N/A	N/A	R	High Byte = Software Version Low Byte = 109
30002	RTD Input 1	-xxx.x	yyyy.y	R	RTD Inputs. See table for range.
30003	RTD Input 2	-xxx.x	yyyy.y	R	Resolution in 0.1°C.
30004	RTD Input 3	-xxx.x	yyyy.y	R	"
30005	RTD Input 4	-xxx.x	yyyy.y	R	"
30006	RTD Input 5	-xxx.x	yyyy.y	R	"
30007	RTD Input 6	-xxx.x	yyyy.y	R	"
30008	Input Status	0	65535	R	bit1 = 0(OK),bit1 = 1(error or open circuit)
30100	DIP Switch	0	65535	R	Status of DIP Switch on Front Panel
40101	RTD Type	1	7	R/W	See RTD Tables.
40102	Line Frequency	50	60	R/W	Line Frequency
40103	Units Type	1	2	R/W	1=°C, 2=°F
40121	Baud Rate	2400	11520	R/W	2400, 4800, 9600, 19200, 38400, 57600, 115200
40122	Parity	0	2	R/W	0 = none, 1 = even, 2 = odd
40123	Stop Bits	1	2	R/W	1 = 1 stop bit, 2 = 2 stop bits
40124	Reply Delay	0	65535	R/W	0 = Disable, >0 = Enable. (x10ms)

## RTD Input Status.

There is one status bits associated with each RTD input. These bits are used to indicate if the input is open circuit or over range. If the input is open circuit or over range, then the error bit will be set.

<u>Bit 1- Error</u>	<u>Bit 2-Not Used</u>	<u>Condition</u>	<u>Status LED</u>
0	0	Input working OK	(LED OFF)
1	0	Open circuit / Over range	(LED ON)

The analog input status can be read in a single register as follows:

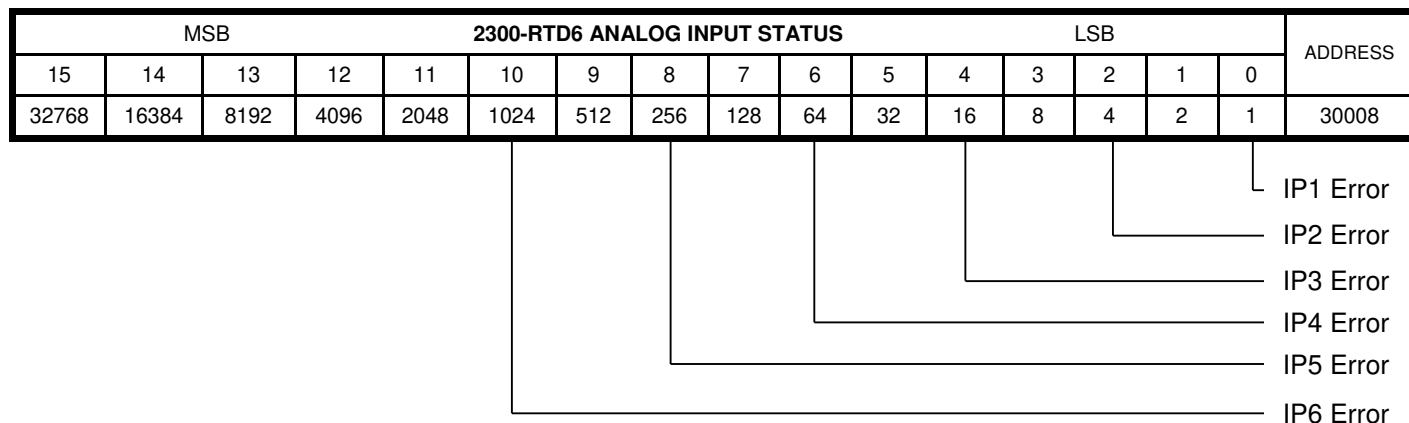

**Intech**  
Instruments

[www.intech.co.nz](http://www.intech.co.nz)

Christchurch Ph: +64 3 343 0646

Auckland Ph: 09 827 1930

Email: [sales@intech.co.nz](mailto:sales@intech.co.nz)