

IN-P

Multifunction Process Indicator



Installation Guide.

IN-P Installation Guide Index.

SECTION 1. – Description and Ordering Information.	Page 3
SECTION 2. – Specifications.	Page 4
SECTION 3. – Case Schematics.	Page 4
SECTION 4. – Input Jumper Configuration.	Page 5
4.1 – <i>Position your input Jumpers.</i>	Page 5
SECTION 5. – Wiring.	Page 6
5.1 – <i>Connect your indicator to the power supply.</i>	Page 6
5.2 – <i>Wire your IF11 analogue input module.</i>	Page 6
5.3 – <i>Wire your analogue output (if fitted).</i>	Page 6
5.4 – <i>Wire your relays (if fitted).</i>	Page 6
5.5 – <i>Wire your serial port (if fitted).</i>	Page 6
5.6 – <i>Wire your function pins (if required).</i>	Page 7
5.7 – <i>Power up your indicator.</i>	Page 7
SECTION 6. – Setup & Calibration.	Page 7
6.1 – <i>Enter calibration PIN.</i>	Page 7
6.2 – <i>Input setup.</i>	Page 7
6.3 – <i>Calibration.</i>	Page 7
6.4 – <i>Averaging.</i>	Page 8
6.5 – <i>Analogue output setup.</i>	Page 8
6.6 – <i>Serial setup.</i>	Page 9
6.7 – <i>Edit calibration PIN.</i>	Page 9
SECTION 7. – Setpoint Setup.	Page 10
7.1 – <i>Enter setpoint PIN.</i>	Page 10
7.2 – <i>Edit setpoints.</i>	Page 10
7.3 – <i>Edit setpoint PIN.</i>	Page 11
SECTION 8. – Setpoint Direct Access.	Page 11
SECTION 9. – Reset PIN Numbers.	Page 11
SECTION 10. – Display Brightness.	Page 11
SECTION 11. – Display Shortcuts.	Page 11

SECTION 1. – Description.

The IN-P Multifunction Process Indicator interfaces smoothly with a wide range of PLC and monitoring systems. Designed specifically for use in process applications, this indicator accepts a variety of inputs. The IN-P can be configured for many different analogue inputs and functions as listed below.

Setup and calibration is simple, with on-screen, step-by-step instructions. The IN-P has a 6-digit LED display, 6 set-points and 5 front panel buttons for easy setup and operator interface. Up to 6 relay outputs, an analogue output and/or communications can also be added.



Ordering Information.

ITEMS		CODE		DESCRIPTION
SERIES	IN-P-			Multifunction Process Indicator
ANALOGUE INPUTS	PRC1-			1x 4~20mA / 0~10V input + 24Vdc excitation
	PRC4-			4x 4~20mA input + 24Vdc excitation
	TC1-			1x Thermocouple input Types B, J, K, N, R, S, T
	TC4-			4x Thermocouple input Types B, J, K, N, R, S, T
	RTD1-			1x RTD Pt100 input
	RTD4-			4x RTD Pt100 input
RELAY OUTPUTS	N-			None
	R2-			2x 5A relay outputs *For PRC1 model only
	R4-			4x 5A relay outputs
	R6-			6x 5A relay outputs *For PRC1 model only
ANALOGUE OUTPUT / RETRANSMISSION	N-			None
	A-			1 x 4~20mA / 0~10V Analogue Output
COMMUNICATIONS	N-			None
	WS232-			1x serial port Isolated RS232
	WS485-			1x serial port Isolated RS485
POWER SUPPLY	HV-			85~265Vac / 95~370Vdc
	LV-			15~48Vac / 10~72Vdc

Ordering Example: **IN-P-RTD4-R2-N-WS485-HV** Multifunction Process Indicator; 4x RTD Pt100 Inputs, 2x 5A relay outputs, 1x serial port RS485, 85~265Vac / 95~370Vdc Power Supply.

Functions available on request:

- A - Auto or manual scanner with alarms.
- B - Maths functions, (i) $\sqrt{\quad}$, (ii) Difference, (iii) Average, (iv) Hi / Lo Select.
- C* - Hold, Tare, Reset (External switches connect to rear terminals).
- D* - Flow Rate + Totalising.
- E* - Energy display & totaliser (flow x ΔT).
- F - Step controller.
- G* - Auto / Manual Station.
- H - Retransmission.
- I - Other Functions – please specify.
- J - Data Logging.

* Available on channel one only.

Product Liability. This information describes our products. It does not constitute guaranteed properties and is not intended to affirm the suitability of a product for a particular application. Due to ongoing research and development, designs, specifications, and documentation are subject to change without notification. Regrettably, omissions and exceptions cannot be completely ruled out. No liability will be accepted for errors, omissions or amendments to this specification. Technical data are always specified by their average values and are based on Standard Calibration Units at 25C, unless otherwise specified. Each product is subject to the 'Conditions of Sale'.

Warning: These products are not designed for use in, and should not be used for patient connected applications. In any critical installation an independent fail-safe back-up system must always be implemented.

SECTION 2. – Specifications.

Power supply	HV: 85~265Vac / 95~370Vdc or LV: 15~48Vac / 10~72Vdc.
Sampling rate	10Hz.
Resolution	16-bit.
Accuracy	0.05% of reading.
Temperature drift	Typically 50ppm/°C.
Calibration	Factory pre-calibrated - automatic or manual user calibration available.
Security	Setup is PIN code protected.
Case	48 x 96 x 119.5mm (H x W x D) / 45.5 x 92.5mm panel cutout.

OPTIONAL

Relay outputs	2, 4 or 6 x 5A Form A relays.
Analogue output	Isolated 16-bit 4~20mA/0~10V output (fully scaleable). Window programmable over any range within the full-scale range of the indicator.
Serial port	Isolated RS485/RS232. <u>Modes:</u> ASCII, Modbus RTU slave, Ranger A. <u>Data rates:</u> 1200~115k2 baud. <u>Parity:</u> Odd, even or none.

JUMPER SELECTABLE OPTIONS

Input range jumper	20mA, Custom, 2V, 10V.
--------------------	------------------------

SECTION 3. – Case Schematics.

The IN-P has a 6-digit, 14-segment alphanumeric LED display, 5 front-panel buttons and 6 setpoint annunciator LED's.

3.1 – Fig 1 - Front view:



BUTTON PRESS FUNCTIONS:

- A - Function 1 **F1** This button is used to access the input setup and calibration menu. See Section 6.
- B - Program **P** This button is typically used to save your settings and advance to the next step in the setup process.
- C - Up **▲** This button is typically used to scroll through options or increase values in the setup menu. Pressing this button from the main display will show the current PEAK value (see Section 11).
- D - Down **▼** This button is typically used to scroll through options or decrease values in the setup menu. Pressing this button from the main display will show the current VALLEY value (see Section 11).
- E - Function 2 **F2** This button is used to access the setpoint setup menu (see Section 7) and the setpoint direct access menu (see Section 8).

3.2 – Fig 2 - Rear view:

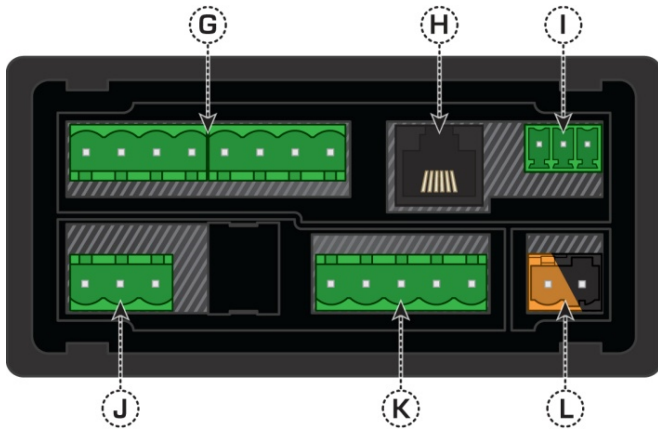

CONNECTOR PINS:

- | | |
|---------------------------------|-------------------------|
| G - Relays | Wiring: Section 5.3 |
| H - Serial port | Wiring: Section 5.5 |
| I - Analogue output | Wiring: Section 5.4 |
| J - IP07 input module | Jumper setup: Section 4 |
| K - Function pins | Wiring: Section 5.2 |
| L - Power supply (HV/LV) | Wiring: Section 5.6 |
| | Wiring: Section 5.1 |

SECTION 4. – Input Jumper Configuration.

Before you Begin:

Before you can begin wiring, the IP07 input module must be removed from the meter case so that the jumpers can be positioned for your input type. Remove the plastic backing plate from the rear of the meter by inserting a screwdriver into the indents circled on the image below:



Before you begin:

Once the backing plate has been removed, gently slide the input module from the case (see Section 3.2J to identify the input module).

4.1 – Position your input jumpers:

The IP07 input module has one jumper, which may need to be repositioned to suit your application. When you have finished, slide the input module back into the case and replace the plastic backing plate.

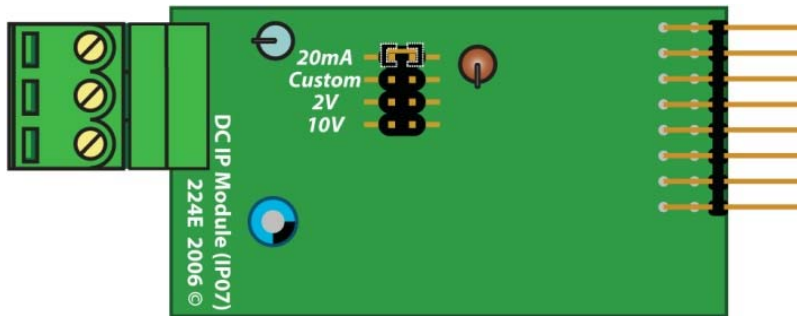

JUMPER POSITIONING:

- | | |
|---------------|-----------------------------------|
| 20mA | Current input (0~20mA or 4~20mA). |
| Custom | Custom input – call for options. |
| 2V | Voltage input (0~2V). |
| 10V | Voltage input (0~10V). |

Example showing a Jumper In & Jumper Out:

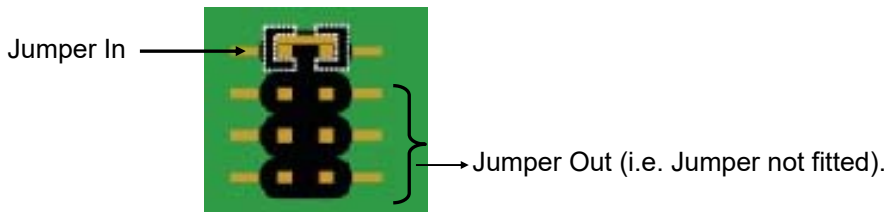

SECTION 5. – Wiring.

Before you Begin:

Determine whether your indicator is configured for low or high voltage power supply. Make sure to check the label on the unit against the colour of the power connector:

Orange = High voltage HV (85~265Vac / 95~370Vdc).

Black = Low voltage LV (15~48Vac / 10~72Vdc).

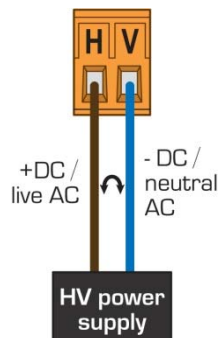
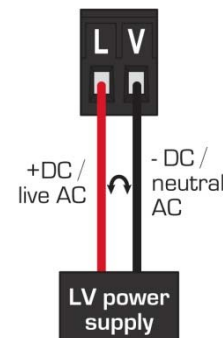
<p>5.1 – Connect your indicator to the power supply Refer to 3.2L.</p> <p>Wire your indicator to your power supply as per the appropriate diagram.</p> <div style="border: 1px solid black; padding: 5px; margin-top: 10px;"> <p style="text-align: center; color: red;">Remember to switch your power supply off before you begin wiring, and NEVER connect your low voltage indicator to mains power.</p> </div>	<p>High voltage (HV) - 85~265Vac, 95~370Vdc</p> 	<p>Low voltage (LV) - 15~48Vac, 10~72Vdc</p> 
--	---	---

5.2 – Wire your IP07 analogue input module:

Refer to 3.2J

Make sure that you have completed Section 4 before you begin wiring your input module. Once you have adjusted your jumper settings as needed (see Section 4) and replaced the plastic backing plate, wire your input module as shown in the appropriate diagram below:

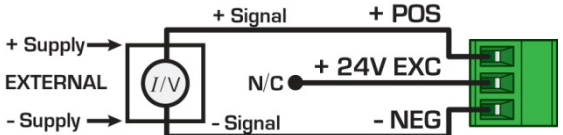
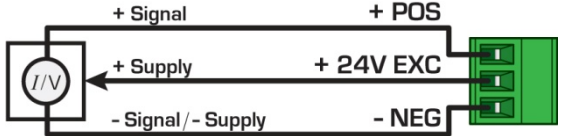
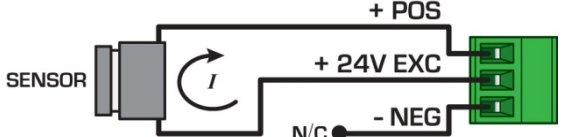
<p>2-wire current or voltage process input: External excitation used.</p>	
<p>3-wire current or voltage process input: Indicator supplied excitation.</p>	
<p>2-wire current input: Loop powered sensor.</p>	

5.3 – Wire your relays (if fitted):

Refer to 3.2G

Wire your relays as per the diagram. Relays can be programmed to operate within the total span range of the indicator. If you do not have any relays fitted, step 5.3 is skipped.

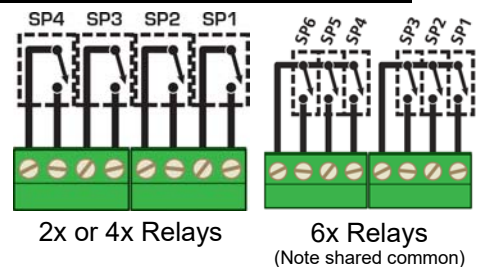

5.4 – Wire your analogue output (if fitted):

Refer to 3.2I

If your indicator has an analogue output fitted, wire it as shown. If you do not have an analogue output, step 5.4 is skipped.



5.5 – Wire your serial port (if fitted):

Refer to 3.2H

If your indicator has a serial port fitted, wire it as per the diagram. If you do not have a serial port fitted then step 5.5 is skipped.

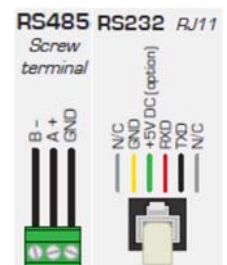

5.6 – Wire your function pins (if required):

Refer to 3.2K

Connect external switches to enable a function to be executed when its switch is activated.

Valley	Clears the valley reading.
Hold	Hold the current display value.
Test	Reset the meter.
Peak	Clears the peak reading.

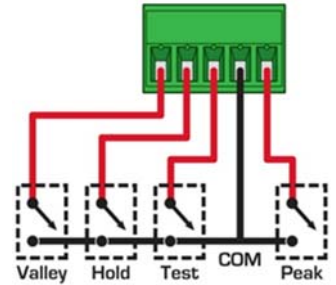

5.7 – Power up your indicator:

Once you have completed the wiring process it is safe to switch on your power supply. Ensure that your display is functioning before you proceed.

SECTION 6. – Setup & Calibration.

Enter the setup and calibration mode by pressing **F1**.

6.1 – Enter calibration PIN:

A **___ ENTER CAL PIN NUMBER** scrolls across the display and toggles with **0**.

Use the **▲** and **▼** buttons to enter your security code (factory default = 1). Then press **P**.

If the correct PIN is entered then the setup is started at 6.2.

If an incorrect PIN number is entered, **___ INCORRECT PIN NUMBER - ACCESS DENIED** scrolls across the display and it returns to the normal operating mode.

Note:

To SKIP or ENTER values - Push



To SELECT a menu input - Push



**You will be given the opportunity to change your PIN number at the end of this section (6.7).
If you have forgotten your PIN number, see Section 9.**

6.2 – Input setup:

Input defaults are set to 4~20mA, 50Hz, no decimal and no rounding.

A **___ INPUT SETUP** scrolls across the display and toggles with **SKIP**.

Press **P** to skip to 6.3, or the **▲** button and then **P** to **ENTER** input setup.

B **___ MAINS FREQUENCY** scrolls across the display and toggles with the currently selected mains frequency. Using the **▲** and **▼** buttons, select either **50HZ** or **60HZ**. Then press **P**.

C **___ INPUT MODE** scrolls across the display and toggles with the currently selected input mode.

Using the **▲** and **▼** buttons, select: **4-20MA** (4~20mA), **0-20MA** (0~20mA), **2 V** (0~2V) or **10 V** (0~10V). Then press **P**.

If you opt to change the input mode in this section then the jumper plug on the input module must also be changed to match. See Section 4 for more information.

D **___ DECIMAL POINT POSITION** scrolls across the display and toggles with the currently selected decimal point position. Use the **▲** and **▼** buttons to choose between: **NO DP**, **0.1**, **0.12**, **0.123**, or **0.1234**, and then press **P**.

E **___ DISPLAY ROUNDING** scrolls across the display and toggles with the currently selected display rounding. Using the **▲** and **▼** buttons, select: **NONE**, **2**, **5** or **10**. Then press **P**.

Rounding is quoted in display counts and is not influenced by decimal point position. For example, if your input signal is 5.3mA, the display will show: 5.3 (for rounding=None), 5.4 (for rounding=2), 5.5 (for rounding=5) or 5.0 (for rounding=10).

6.3 – Calibration:

A **___ CALIBRATION TECHNIQUE** scrolls across the display and toggles with **SKIP**. Press **P** to skip to 6.4, or use the **▲** and **▼** buttons to select either **AUTO**, **MANUAL** or **S.G.** (specific gravity), and then press **P**.

AUTO - The automatic (key-in) 2-point calibration procedure uses zero and span values to calculate the scale and offset. This is the most accurate calibration method, but requires known low and high input signals (or the use of a calibrator).

MANUAL - The manual calibration procedure uses low and high display values, and is intended for a pre-calibrated sensor with a known output range. (For example 4mA=0 and 20mA=1000.) It does not require any input signals to be applied to the indicator during calibration.

S.G. - The specific gravity calibration procedure allows the user to enter a scale factor which is used to compensate for changes in the specific gravity of different substances. This does not constitute a full calibration and assumes that either an automatic or manual calibration has been applied previously with the S.G. value set to 1.0.

If you selected AUTO in 6.3A:

- B** **___ APPLY LOW INPUT SIGNAL** ----- **ENTER LOW DISPLAY VALUE** scrolls across the display. Apply the required low input signal to the indicator. Using the ▲ and ▼ buttons, enter your low end display value. Then press **P** to accept.
- ___ APPLY HIGH INPUT SIGNAL** ----- **ENTER HIGH DISPLAY VALUE** scrolls across the display. Apply the required high input signal to the indicator. Using the ▲ and ▼ buttons, enter your high end display value. Then press **P**. If calibration is successful, the indicator will return to the operational display.

___ CALIBRATION FAILED

A calibration failure results when the indicator cannot detect any change in input signal during the calibration procedure. After viewing this message you will be redirected to the operational display. Check your input signal and connections, and then repeat the process.

If you selected MANUAL in 6.3A:

- C** **___ ENTER DISPLAY VALUE FOR (X)** scrolls across. (X=0mA/4mA/0V, depending on your selection in 6.2C.) Using the ▲ and ▼ buttons, enter your display value for the selected low input signal. Then press **P**.
- ___ ENTER DISPLAY VALUE FOR (X)** scrolls across. (X=20mA/2V/10V, depending on your selection in 6.2C.) Using the ▲ and ▼ buttons, enter your display value for the selected high input signal. Then press **P** to accept the new calibration values and return to the operational display.

If you selected S.G. in 6.3A:

- D** **___ SPECIFIC GRAVITY** scrolls across and toggles with the current specific gravity scale factor. Adjust this value using the ▲ and ▼ buttons, and then press **P** to accept and return to the operational display.

6.4 – Averaging:

Your indicator has input signal averaging, guaranteeing stable measurement. If the input exceeds the averaging window value it will not average, ensuring fast response.

- A** **___ AVERAGING PARAMETERS** scrolls across the display and toggles with **SKIP**. Press **P** to skip to 6.5, or the ▲ button and then **P** to **ENTER** averaging setup.
- B** **___ AVE SAMPLES** scrolls across the display and toggles with the currently selected averaging. Use the ▲ and ▼ buttons to alter the signal averaging and then press **P**. *Increasing the number of samples will stabilise measurement, but it will also slow down response rates.*
- C** **___ AVE WINDOW** scrolls across the display and toggles with the currently selected averaging window value. Use the ▲ and ▼ buttons to alter the signal averaging window, and then press **P**.

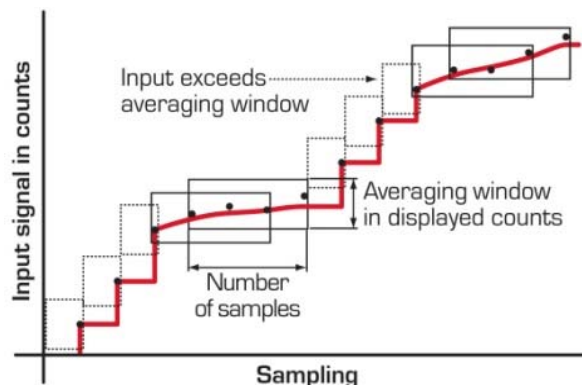

If your input signal contains large noise spikes then you can increase the size of averaging window to ensure that these pulses are still averaged. However, increasing the averaging window too far will reduce the ability of the indicator to respond quickly to real changes in input signal. Setting the averaging window to zero will turn off the window mode and give continuous averaging as per the selected averaging samples.

6.5 – Analogue output setup:

If your indicator does not have this option installed then you will not view this section - setup will continue at 6.6.

- A** **___ ANALOG OUTPUT SETUP** scrolls across display and toggles with **SKIP**. Press **P** to skip to 6.6, or the ▲ button and then **P** to **ENTER** analogue output setup.
- B** **___ LOW SCALE VALUE FOR ANALOG OUTPUT** scrolls across the display and toggles with the current selection. Use the ▲ and ▼ buttons to enter your cal low position, and then press **P**. This sets the display value for cal low (as at 6.5E).
- C** **___ HIGH SCALE VALUE FOR ANALOG OUTPUT** scrolls across the display and toggles with the current selection. Use the ▲ and ▼ buttons to enter your cal high position, and then press **P**. This sets the display value for cal high (as at 6.5F).
- D** **___ CALIBRATE ANALOG OUTPUT?** scrolls across the display and toggles with **SKIP**. If you do not wish to calibrate your analogue output, press **P** now. If you would like to calibrate your analogue output: Set the analogue output board jumper in the correct position (see Section 4) and connect a mA or volt meter across the analogue output connector (see 5.3). Press the ▲ button to select **ENTER** and then **P** to enter calibration mode.

- E** **___ CAL LOW ANALOG OUTPUT** scrolls across the display and toggles with a calibration number. Using the ▲ and ▼ buttons, calibrate your low analogue output as required. Then press **P**. The display value is shown in internal units (mA).
- F** **___ CAL HIGH ANALOG OUTPUT** scrolls across the display and toggles with a calibration number. Using the ▲ and ▼ buttons, calibrate your high analogue output as required. Then press **P**. The display value is shown in internal units (mA).

6.6 – Serial setup:

If your indicator does not have this option installed, then you will not view this section - setup will continue at 6.7.

- A** **___ SERIAL SETUP** scrolls across the display and toggles with **SKIP**. Press **P** to skip to 6.7, or the ▲ button and then **P** to **ENTER** serial port setup.
- B** **___ SERIAL MODE** scrolls across the display and toggles with the currently selected serial mode. Using the ▲ and ▼ buttons, select: **ASCII**, **MODBUS** (RTU) or **RNGR A** (Ranger A). Then press **P**. **ASCII** is a simple protocol that allows connection to various PC configuration tools. **MODBUS** is an industry standard RTU slave mode that allows connection to a wide range of devices, such as PC's or PLC's. **RNGR A** is a continuous output, used to drive remote displays and other instruments in the Rinstrum™ range. (Ranger is a trade name belonging to Rinstrum Pty Ltd.)
- C** **___ BAUD RATE** scrolls across the display and toggles with the current selection. Use the ▲ and ▼ buttons to select: **300**, **600**, **1200**, **2400**, **4800**, **9600**, **19200** or **38400**. Then press **P**.
- D** **___ PARITY** scrolls across the display and toggles with the current selection. Use the ▲ and ▼ buttons to select: **NONE**, **ODD** or **EVEN**. Then press **P**.
- E** **___ SERIAL ADDRESS** scrolls across the display and toggles with the current selection. Use the ▲ and ▼ buttons to set the serial address, and then press **P**. The serial address parameter is used to identify a particular device when it is used with other devices in a system. (It applies particularly to Modbus mode when used on a RS485 network.) The serial address of the indicator must be set to match the serial address defined in the master device.

RANGER A - This allows the indicator to drive a remote display from the Rinstrum range. The following shows the output string format when Ranger A output is selected: **<Start> <Sign> <Output Value> <Status> <End>**

STRING CHARACTER(S):

<Start>	STX character (ASCII 02).
<Sign>	Output value sign (space for + and dash for -).
<Output Value>	Seven character ASCII string containing the current output value and decimal point. (If there is no decimal point, then the first character is a space. Leading zero blanking applies.)
<Status>	Single character output value status: U=Under, O=Over, E=Error.
<End>	ETX character (ASCII 03).

MODBUS REGISTERS - These are all holding registers and should be accessed via function codes 3 and 6. Register addresses are displayed in the Modicon™ addressing format. i.e. Register 65=40065 (subtract 1 for direct addressing).

16-BIT		32-BIT SIGNED (2x16-bit)	
40001	Alarm status (Bit 0=SP1, Bit1=SP2, Bit 2=SP3, Bit 3=SP4)	40068	SP 4 hysteresis
40065	SP 1 hysteresis	40074	SP 4 make delay
40071	SP 1 make delay	40069	SP 5 hysteresis
40066	SP 2 hysteresis	40075	SP 5 make delay
40072	SP 2 make delay	40070	SP 6 hysteresis
40067	SP 3 hysteresis	40076	SP 6 make delay
40073	SP 3 make delay	40527	Valley
		40535	Setpoint 1
		40537	Setpoint 2
		40539	Setpoint 3
		40541	Setpoint 4
		40543	Setpoint 5
		40545	Setpoint 6
		40587	D/A scale low value
		40591	D/A scale high value

6.7 – Edit calibration PIN:

- A** **___ EDIT CAL PIN NUMBER** scrolls across the display and toggles with **SKIP**. Press **P** to skip and return to the operational display, or the ▲ button and then **P** to **ENTER**.
- B** **___ ENTER NEW CAL PIN NUMBER** scrolls across the display and toggles with the current PIN (default = 1). Using the ▲ and ▼ buttons, enter your new calibration PIN number. Then press **P** to exit and return to the operational display.

SECTION 7. – Setpoint Setup.

Enter the setpoint setup mode by pressing and holding the **F2** button for 3 seconds.

Note:

To SKIP or ENTER values - Push



To SELECT a menu input - Push



7.1 – Enter setpoint PIN:

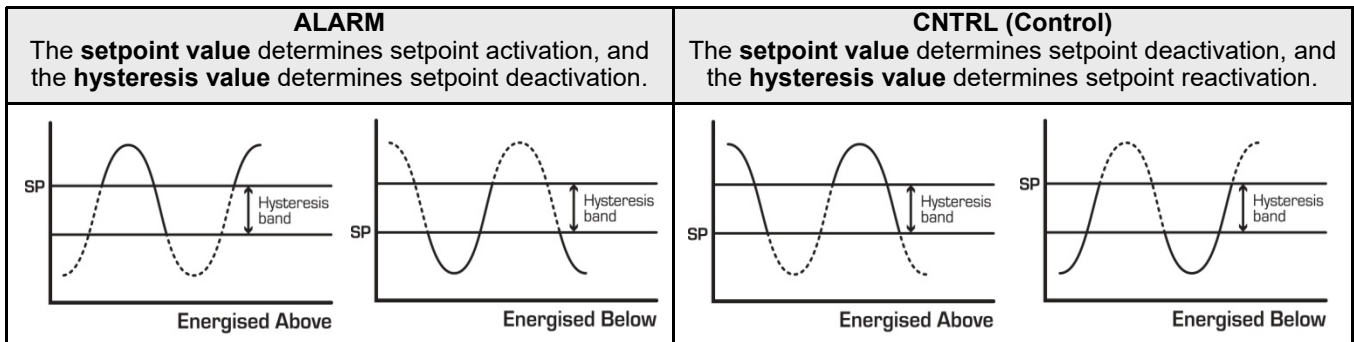

- A** **___ ENTER SP PIN NUMBER** scrolls across the display and toggles with **0**. Use the **▲** and **▼** buttons to enter your security code (factory default = 1). Then press **P**. If the correct PIN is entered then the setup is started at 7.2. If an incorrect PIN number is entered, **___ INCORRECT PIN NUMBER - ACCESS DENIED** scrolls across the display and it returns to the normal operating mode.

**You will be given the opportunity to change your PIN number at the end of this section (7.3).
If you have forgotten your PIN number, see Section 9.**

7.2 – Edit setpoints:

- A** **___ EDIT SETPOINT** scrolls across the display and toggles with **SKIP**. Press **P** to skip to 7.4, or use the **▲** and **▼** buttons to select a setpoint to edit: **SP 1**, **SP 2**, **SP 3**, **SP 4**, **SP 5** or **SP 6**. Then press **P**.
SP 3-6 are not available for models with only 2 relays installed. SP 5-6 are not available for models with only 4 relays installed.
- B** **___ SP VALUE** scrolls across the display and toggles with the last setpoint value entered. Using the **▲** and **▼** buttons, adjust the display value at which the setpoint will activate. Then press **P**.
- C** **___ SP ACTIVATION** scrolls across the display and toggles with the last selected setpoint activation. Use the **▲** and **▼** buttons to select **ABOVE** or **BELOW** and then press **P**.
ABOVE - relay turns on above the setpoint value and off below it.
BELOW - relay turns on below the setpoint value and off above it.
- D** **___ SP TYPE** scrolls across the display and toggles with the last selected setpoint type. Using the **▲** and **▼** buttons, select either **ALARM** or **CNTRL (Control)**. Then press **P**.
- E** **___ HYSTERESIS VALUE** scrolls across the display and toggles with the current selection. Use the **▲** and **▼** buttons to adjust this value if required. Then press **P**.
The hysteresis value defines the separation band between setpoint activation and deactivation. Hysteresis will operate as per the specified type setting (see 7.2D).
- F** **___ MAKE DELAY** scrolls across the display and toggles with the current selection. Use the **▲** and **▼** buttons to adjust this value if required. Then press **P**.
This value is displayed in seconds with a 0.1 second resolution, and is the time delay before the relay energises.
- G** **___ OPEN ACCESS TO SP VALUE** scrolls across the display and toggles with the last selected direct access setting. Use the **▲** and **▼** buttons to select either **YES** or **NO**, and then press **P**.
*When enabled, this option allows the setpoint value to be edited directly after pressing the **F2** button, without needing to enter a PIN number or go through all of the other options. Each setpoint can individually have this option enabled or disabled.*

If you selected SP 1 in 7.2A - Skip 7.2H and continue to 7.2I now.

- H** **___ TRAIL SP1** scrolls across the display and toggles with the current trailing setting. Using the **▲** and **▼** buttons, select either **OFF** or **ON**, and then press **P**.
*If you choose ON, the selected setpoint will become an offset value, which is effectively added to the value of **SP 1**.*
- I** **___ EDIT SETPOINT** scrolls across the display and toggles with **SKIP**. You are now back at 7.2A. To edit another setpoint, follow the instructions from 7.2A-I. If you do not wish to edit another setpoint, press **P** now to proceed to 7.3.

7.3 – Edit setpoint PIN:

- A **___ EDIT SP PIN NUMBER?** scrolls across the display and toggles with **SKIP**.
Press **P** to skip and return to the operational display, or the **▲** button and then **P** to **ENTER**.
- B **___ ENTER NEW SP PIN NUMBER** scrolls across the display and toggles with the current PIN (default = 1).
Using the **▲** and **▼** buttons, enter your new totalizer reset and setpoint entry PIN number.
Then press **P** to **EXIT** and return to the operational display.

SECTION 8. – Setpoint Direct Access.

If none of the setpoints have their direct access option enabled then the **F2** button will not respond to a short press. (See 7.2G to enable.)

8.1 – Setpoint direct access:

- A Begin by pressing the **F2** button for half a second. The name of the first access-enabled setpoint (**SP 1**, **SP 2**, **SP 3**, **SP 4**, **SP 5** or **SP 6**) will appear on the display and toggle with the current value for that setpoint. Using the **▲** and **▼** buttons, adjust the selected value.
Then press **P** to accept and progress to the next access-enabled setpoint.
SP3-4 are not available for models with only two relays installed.
 - B Pressing **P** for the last access-enabled setpoint will exit and return to the operational display.
-

SECTION 9. – Reset PIN Numbers.

If you have forgotten either of your PIN numbers, follow the procedure below to reset both the calibration and setpoint entry PIN's to their factory default of 1.

- A Press the **▲**, **▼** and **P** buttons at the same time.
(This key combination can be difficult to execute and you may need several attempts to get it right.)
- B When successful, a factory identification text will scroll across the display, followed by:
___ ALL PIN NUMBERS RESET TO 1.
- C Reset the PIN numbers individually as required by following the instructions in Sections 6.7 and 7.3, entering '1' whenever you are prompted for your current PIN.

SECTION 10. – Display Brightness.

To adjust the brightness of the LED display:

- A Press the **P** and **▲** buttons together from the operational display. **BRI** appears on the screen and toggles with the current brightness setting.
- B Use the **▲** and **▼** buttons to adjust the brightness of the LED backlight as required, and then press **P**.
The display returns to normal operating mode.

SECTION 11. – Display Shortcuts.

Use these shortcuts for quick viewing of specified parameters from the operational display:

- To view the maximum (peak) value:** Press the **▲** button for ½ a second. The word **PEAK** appears on the display and toggles with the maximum measured process input value.
Press **P** to return to the operational display.
- To view the minimum (valley) value:** Press the **▼** button for ½ a second. The word **VALLEY** appears on the display and toggles with the minimum measured process input value.
Press **P** to return to the operational display.
- To reset peak or valley:** Press both the **▲** and **▼** buttons together while the required parameter is being displayed.

Intech[®]
Instruments
www.intech.co.nz
Christchurch Ph: +64 3 343 0646
Auckland Ph: 09 827 1930
Email: sales@intech.co.nz