

INTECH Micro 2100-M REV. 1.1



Installation Guide.

Section A. Description, Ordering and Specifications.

2100-M Installation Guide Index.

Section A. Description, Ordering and Specifications.

Features and Ordering Information.	Page 3
Specifications.	Page 4
Dimensions.	Page 5
Terminals and Layout	Page 6

Section B. Input Programming.

Notes for Programming all Models.	Page 7
2100-M-I Input Programming.	Page 7
2100-M-R Input Programming.	Page 8
2100-M-V Input Programming.	Page 9
2100-M Output Programming.	Page 9
H1 Power Supply Settings.	Page 9

Section C. Input and Output Connection Diagrams.

2100-M-I Input Connection Diagram for 4~20mA Inputs.	Page 10
2100-M-R Input Connection Diagram for RTD Inputs.	Page 10
2100-M-V Input Connection Diagram for Voltage Inputs.	Page 11
Connection Diagram Using an LPI-D Current Loop Isolator on the Output.	Page 11
Connection Diagram Using an XI-P1 Current Loop Isolator on the Output.	Page 12

Section D. Connecting to a Microscan Scada System.

2100-A16 Analogue Input Expansion - Using 2100-M Analogue Input Multiplexer.	Page 12
Option 1. 5 Wire Connection Diagram.	Page 12
Option 2. 4 Wire Connection Diagram.	Page 13
IN-2000-AI Remote Station Connection Diagram.	Page 13

Section E. Connection to a PLC.

Clock/Reset Mode, PLC Installation Guide.	Page 14
Binary Channel Selection Mode, PLC installation Guide.	Page 14
Binary Channel Selection Mode Table.	Page 14
PLC Connection Diagram Using External Power Supply & 24V Common Open Collectors.	Page 15
PLC Connection Diagram Using 2100-M Power Supply & 15V Common Open Collectors.	Page 15
2100-M Rev.1 PLC Connection Diagram Using External Power Supply & 0V Common Open Collectors.	Page 16
2100-M Rev.1 PLC Connection Diagram Using 2100-M Power Supply & 0V Common Open Collectors.	Page 16
2100-M Rev.0 PLC Connection Diagram Using External Power Supply & 0V Common Open Collectors.	Page 17
2100-M Rev.0 PLC Connection Diagram Using 2100-M Power Supply & 0V Common Open Collectors.	Page 17
Analogue Signal Converted to Frequency for a PLC, using a TWI-FO.	Page 18

Section F. Wiring, Installation and Maintenance.

Mounting.	Page 18
Cover Removal and Fitting.	Page 18
Wiring.	Page 18
2100-M-R RTD'S.	Page 18
Commissioning.	Page 19
Maintenance.	Page 19

INTECH Micro 2100-M Rev 1.1

16 Channel
Programmable
Multiplexer.

Features.

- 16 Channel Multiplexer.
- Field Programmable Inputs.
- Field Programmable Output.
- Input Types Available:
 - ◊ MilliAmp;
 - ◊ Pt100 RTD;
 - ◊ Volts and Millivolts;
- Clock/Reset Channel Selection, or Binary Channel Selection.
- High Accuracy 0.1%.
- Compact DIN Rail Mount Enclosure.
- Easy to Install.
- Low Cost Expansion for PLCs.
- Solid State Switches for Reliability.



2100 IntechMicro Series:

- 2100-A16: 16AI, 4DI, 2 Relay Out, 2 AO.
- 2100-D: 12DI, 12 Relay Out.
- 2100-IS: Isolated RS232 to RS422/485.
- 2100-MR: 16 RTD Input Multiplexer.
- 2100-NET: Isolated Ethernet to RS232/422/485.
- 2100-R: 16 Relay Expansion for 2100-A16.

Description.

The 2100-M (previously the EXPO-3) can multiplex up to 16 inputs, into one output, selectable by a PLC or a Data Logging System. It uses solid state switches, making it extremely reliable and durable.

The PLC only requires two digital outputs and one analogue input to select and receive data from the 2100-M. For each additional 2100-M added to the system only one more analogue input is required. (The typical fan-out for most PLC's digital outputs is eight 2100-Ms) The 2100-M-I, the 2100-M-R and the 2100-M-V are on board input / output programmable.

The 2100-M is used extensively in industrial plants, with proven reliability and accuracy. It comes complete and ready to operate in a compact DIN rail mount enclosure.

Ordering Information



Ranging Options of the 2100-M

Input Model	-M	Input Range - IR				Output -AO	Channel Selection	-CS	Sensor Break	-SB	Power Supply ⁽³⁾	-PS
		Standard	Range Select	Min ⁽¹⁾	Max ⁽²⁾							
mA	I			2mA	20mA	4~20mA	Clock/Reset	CR	Upscale	US	85~264Vac/dc	H
RTD	R			20°C	600°C	0~20mA	Binary	BIN	Downscale	DS	23~90Vdc	M
mV & V	V			200mV	10V	0~10Vdc						
						0~5Vdc						
						Custom						

Note 1) Minimum Range = Signal High - Signal Low.

Note 2) Maximum Range = Signal High - Signal Low.

Note 3) Sensor Break only applies to the RTD (-R) input model.

Note 4) Power supply 'H' is field selectable for 'M', and 'M' for 'H'. Power supply 'L' must be ordered separately.

Ordering Examples.

- 1/ 2100-M-R -50/+50 4/20mA H RTD Input -50~+50°C; 4~20mA Output; 85~264Vac/dc Power Supply.
- 2/ 2100-M-R 0/100 4/20mA M RTD Input 0~100°C; 4~20mA Output; 23~90Vdc Power Supply.

Quality Assurance Programme.

The modern technology and strict procedures of the ISO9001 Quality Assurance Programme applied during design, development, production and final inspection grant long term reliability of the instrument. This instrument has been designed and built to comply with EMC and Safety Standards requirements.

Common 2100-M Specifications.

Inputs:	16 inputs. Refer next page for individual model specifications.		
Output:	-Programmable	0~20mA	500Ω Load Maximum.
		4~20mA	500Ω Load Maximum.
		0~10mA	1000Ω Load Maximum.
		2~10mA	1000Ω Load Maximum.
		0~5Vdc	Maximum Output Drive = 8mA.
		1~5Vdc	Maximum Output Drive = 8mA.
		0~10Vdc	Maximum Output Drive = 8mA.
		2~10Vdc	Maximum Output Drive = 8mA.
Channel Selection Inputs:	4 Opto-isolated Inputs each with LED indication. Inputs Bi-directional. (CS COM can be +ve or -ve.)		
-Hysteresis	0.2V.		
-Load	@ 6V	1mA per Channel.	
	@ 12Vdc	4mA per Channel.	
	@ 15Vdc	5mA per Channel.	
	@ 20Vdc	8mA per Channel.	
	@ 24Vdc	9mA per Channel.	
CLOCK and RESET Pulse Length	20msec. Min.		
Channel Selection Pulse Amplitude	6~40Vdc.		
Settling Time Before Reading	100msec.		
	- Multiple readings with averaging recommended.		
Power:	-H	85~264Vac/dc; 50/60Hz; 10VA.	
	-M	23~90Vdc; 10VA.	
		Refer to '2100-M H1 Power Supply Settings' for voltage selection instructions.	
	-L	10~28Vac/dc; 50~60Hz; 10VA. (Discontinued.)	
Safety and EMC Compliances:			
EMC Emissions Compliance	EN 55022-A.		
EMC Immunity Compliance	EN 50082-1.		
Safety Compliance	EN 60950.		
Mains Isolation	250Vac.		
Mains Isolation Test Voltage	-To all Inputs and Outputs:	3000Vac 50Hz for 1min.	
	-To Earth:	1500Vac 50Hz for 1min.	
Control Isolation Test Voltages:	-Channel control to input/outputs.	1000Vdc for 1min.	
	Input/Output isolation is not provided. Isolation units are available.		
	- Refer to the connection diagrams.		
General Specifications:	(Unless otherwise stated in other input specifications.)		
Accurate to	<±0.1% FSO Typical.		
Linearity & Repeatability	<±0.1% FSO Typical.		
Channel Separation	<±0.1% FSO Typical.		
Ambient Drift	<±0.01%/C FSO Typical.		
RF Immunity	<±1% Effect FSO Typical.		
Operating Temperature	0~60C.		
Storage Temperature	-20~80C.		
Operating Humidity	5~85%RH Max. Non-Condensing.		
Housing	-Material	ABS Inflammability V0 (UL94).	
	-Dimensions	L=195, W=120, H=70mm.	
	-Mounting	35mm Symmetrical Mounting Rail.	
	-Weight	700g. Includes Packaging.	

Individual 2100-M Model Specifications.

2100-M-R, 3-wire RTD Inputs

Inputs	16 Single Ended RTD Inputs. All 2nd 'B' Terminals Connected.
RTD Type	3 Wire Pt100 RTD DIN 43760:1980 Standard Input. Other RTD input types available on request. (eg Ni100, Cu10, etc.)
Ranging	Field Programmable Within -200°C to 600°C. Minimum Range = 20C°.
Sensor Current	1mA Multiplexed.
Lead Resistance	5Ω/Lead Maximum Recommended. All temperature probes must be isolated from each other and earth.
Sensor Fail	Upscale: >110%FSO. (Load Dependant.) Downscale: ≤1%FSO Typical

2100-M-I, mA Inputs

Inputs	16 Single Ended Inputs. All -Ve Terminals Connected.
Ranging	Field Programmable Within 0 to 20mAdc. Minimum Range = 2mA.
Input Resistance	100Ω.
Maximum Over-range	35mAdc Continuous.

2100-M-V, Voltage Inputs

Inputs	16 Single Ended Inputs. All -Ve Terminals Connected.
Ranging	Field Programmable Within 0 to 10Vdc. Minimum Range = 200mV.
Input Resistance	100kΩ.
Maximum Over-range	26Vdc Continuous.

Contact **Intech Instruments Ltd** for more detailed programming information.

Product Liability. This information describes our products. It does not constitute guaranteed properties and is not intended to affirm the suitability of a product for a particular application. Due to ongoing research and development, designs, specifications, and documentation are subject to change without notification. Regrettably, omissions and exceptions cannot be completely ruled out. No liability will be accepted for errors, omissions or amendments to this specification. Technical data are always specified by their average values and are based on Standard Calibration Units at 25°C, unless otherwise specified. Each product is subject to the 'Conditions of Sale'.

Warning: These products are not designed for use in, and should not be used for patient connected applications. In any critical installation an independent fail-safe back-up system must always be implemented.



CAUTION: Dangerous voltages may be present. The 2100-M has no user serviceable parts. Protective enclosure only to be opened by qualified personnel. Remove ALL power sources before removing protective cover.



2100-M Rev 1.1 Dimensions.

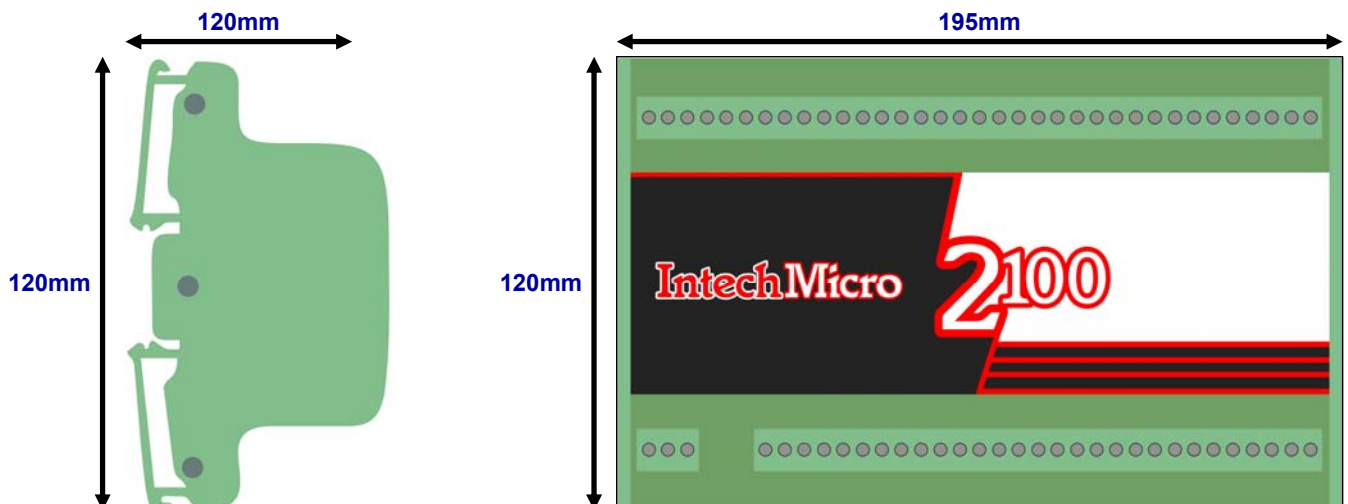

2100-M Terminal and Layout.

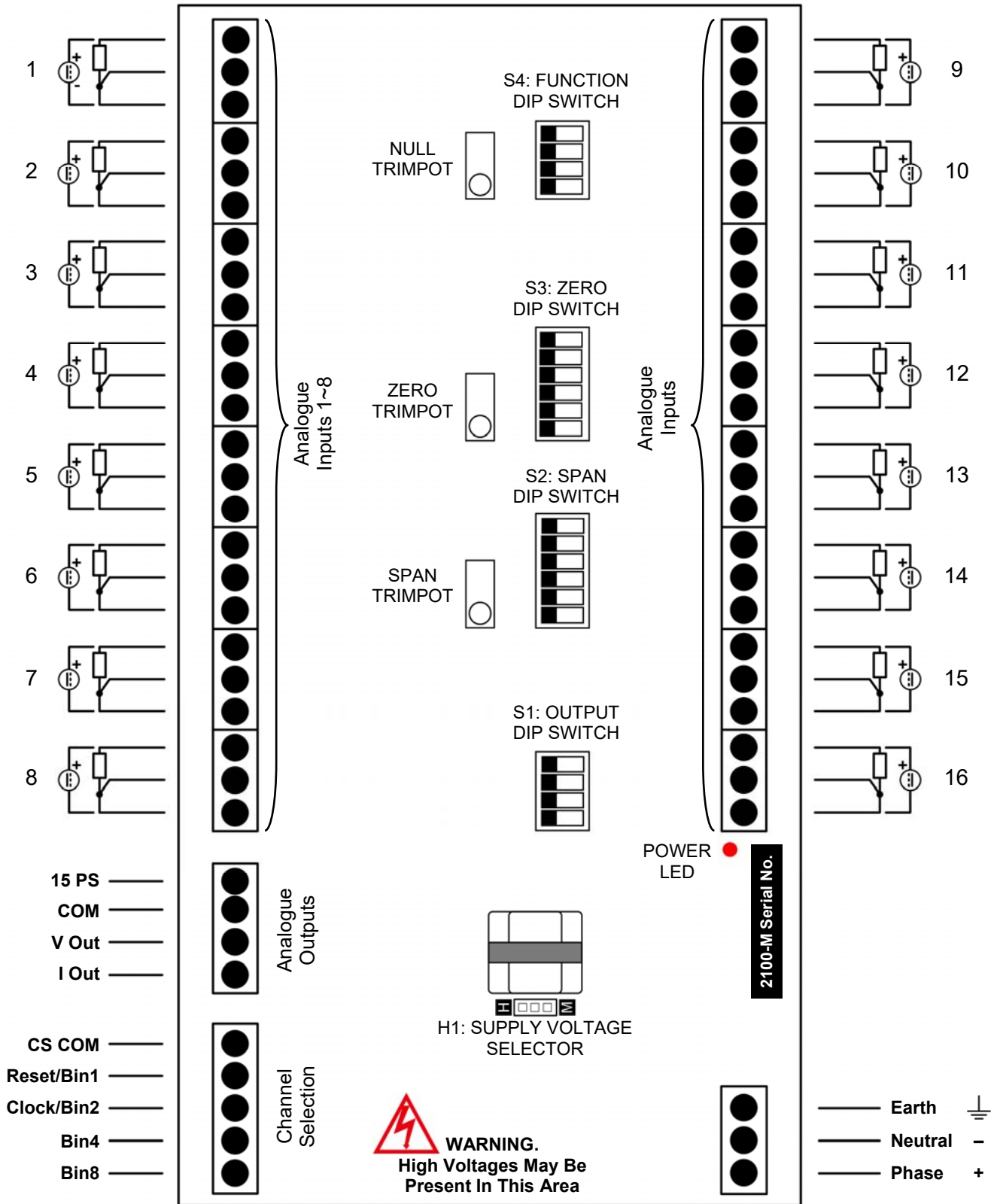

Only adjust jumpers and DIP switches with power OFF.

CAUTION: Dangerous voltages may be present. The 2100-M has no user serviceable parts. Protective enclosure only to be opened by qualified personnel. Remove ALL power sources before removing protective cover.

Section B. Input Programming.

2100-M Input Programming - Notes for Programming all Models.

For All Programming Tables - Switch Status: 0=OFF, 1=ON, X=Any Position.

Gain Value	1	2	4	8	16	32
DIP Switch No.	1	2	3	4	5	6

If a gain value of 28 is required, put DIP switch No's 3, 4, 5 OFF (ie, gains of 4 + 8 + 16 = 28) and all the other DIP switches ON. Enter the Zero or Span gain value into the appropriate Zero or Span DIP switch. DIP switches are accessed by removing the cover.

Important: Once a range has been selected on the DIP switches the 2100-M should be checked using the appropriate signal levels. DIP switch settings will normally be accurate to 1%. (This can be greater for smaller ranges.) Use the Zero and Span Pots in the 2100-M to finely calibrate the desired range. Using a small screwdriver turn the Pots clockwise to increase the output, and anticlockwise to decrease the output.

Note: Do not adjust the NULL Pot. This is factory set.

2100-M-I Input Programming.

If the input range is not listed in the programming table, use the following formulae to work out the Zero and Span switch Gain Values. Use the table at the top of the previous page to calculate DIP switch settings from the calculated gain values.

$$\text{Span Gain} = \frac{80}{\text{signal high} - \text{signal low}}$$

$$\text{Zero Gain} = \text{signal low} \times 4 \quad \text{Note: Eg. Enter 20mA as 20.}$$

Input Range mAdc	S2-Span						S3-Zero						S4-Function			
	1	2	3	4	5	6	1	2	3	4	5	6	1	2	3	4
0~2mA	1	1	1	0	1	0	1	1	1	1	1	1	X	0	X	
0~4mA	1	1	0	1	0	1	1	1	1	1	1	1	X	0	X	
0~5mA	1	1	1	1	0	1	1	1	1	1	1	1	X	0	X	
0~8mA	1	0	1	0	1	1	1	1	1	1	1	1	X	0	X	
0~10mA	1	1	1	0	1	1	1	1	1	1	1	1	X	0	X	
0~16mA	0	1	0	1	1	1	1	1	1	1	1	1	X	0	X	
0~20mA	1	1	0	1	1	1	1	1	1	1	1	1	X	0	X	
1~5mA	1	1	0	1	0	1	1	1	0	1	1	1	0	0	X	
2~10mA	1	0	1	0	1	1	1	1	1	0	1	1	0	0	X	
4~12mA	1	0	1	0	1	1	1	1	1	1	0	1	0	0	X	
4~20mA	0	1	0	1	1	1	1	1	1	1	0	1	0	0	X	
12~20mA	1	0	1	0	1	1	1	1	1	1	0	0	0	0	X	

Set to '0' for Binary Channel Selection.
Set to '1' for Clock/Reset Channel Selection.

2100-M-R Input Programming.

If the input range is not listed in the programming table, use the following formulae to work out the Zero and Span switch Gain Values. Use the table at the top of this page to calculate DIP switch settings from the calculated gain values.

$$\text{deg C Span Gain} = \frac{1200}{\text{deg C High} - \text{deg C Low}}$$

$$\text{deg F Span Gain} = \frac{2400}{\text{deg C High} - \text{deg C Low}}$$

$$\text{deg C Zero Gain} = \frac{\text{deg C Low}}{5}$$

$$\text{deg F Zero Gain} = \frac{\text{deg F Low}}{10}$$

If Zero Gain is:
 1/ +ve Put S4-1 OFF (Positive Offset)
 2/ -ve Put S4-1 ON (Negative Offset)

Input Range C (Put S4-2 OFF)	Input Range F (Put S4-2 ON)	S2-Span						S3-Zero						S4-Function			
		1	2	3	4	5	6	1	2	3	4	5	6	1	2	3	4
0~20C	0~40F	1	1	0	0	0	0	1	1	1	1	1	1	X	SET TO '0' FOR CELC I U S SET TO '1' FOR FAHRENHEIT.	Set to '0' for UPSCALE Sensor Break. Set to '1' for DOWNSCALE Sensor Break.	Set to '0' for Binary Channel Selection. Set to '1' for Clock/Reset Channel Selection.
0~25C	0~50F	1	1	1	1	0	0	1	1	1	1	1	1	X			
0~30C	0~60F	1	1	1	0	1	0	1	1	1	1	1	1	X			
0~40C	0~80F	1	0	0	0	0	1	1	1	1	1	1	1	X			
0~50C	0~100F	1	1	1	0	0	1	1	1	1	1	1	1	X			
0~60C	0~120F	1	1	0	1	0	1	1	1	1	1	1	1	X			
0~70C	0~140F	0	1	1	1	0	1	1	1	1	1	1	1	X			
0~75C	0~150F	1	1	1	1	0	1	1	1	1	1	1	1	X			
0~80C	0~160F	0	0	0	0	1	1	1	1	1	1	1	1	X			
0~90C	0~180F	0	1	0	0	1	1	1	1	1	1	1	1	X			
0~100C	0~200F	1	1	0	0	1	1	1	1	1	1	1	1	X			
0~110C	0~220F	0	0	1	0	1	1	1	1	1	1	1	1	X			
0~120C	0~240F	1	0	1	0	1	1	1	1	1	1	1	1	X			
0~125C	0~250F	1	0	1	0	1	1	1	1	1	1	1	1	X			
0~150C	0~300F	1	1	1	0	1	1	1	1	1	1	1	1	X			
0~200C	0~400F	1	0	0	1	1	1	1	1	1	1	1	1	X			
0~250C	0~500F	0	1	0	1	1	1	1	1	1	1	1	1	X			
0~300C	0~600F	1	1	0	1	1	1	1	1	1	1	1	1	X			
0~400C	0~800F	0	0	1	1	1	1	1	1	1	1	1	1	X			
0~600C	0~1200F	1	0	1	1	1	1	1	1	1	1	1	1	X			
-10~10C	-20~20F	1	1	0	0	0	0	1	0	1	1	1	1	1			
-10~20C	-20~40F	1	1	1	0	1	0	1	0	1	1	1	1	1			
-10~40C	-20~80F	1	1	1	0	0	1	1	0	1	1	1	1	1			
-20~20C	-40~40F	1	0	0	0	0	1	1	1	0	1	1	1	1			
-20~30C	-40~60F	1	1	1	0	0	1	1	1	0	1	1	1	1			
-25~25C	-50~50F	1	1	1	0	0	1	0	1	0	1	1	1	1			
-25~50C	-50~100F	1	1	1	1	0	1	0	1	0	1	1	1	1			
-30~20C	-60~40F	1	1	1	0	0	1	1	0	0	1	1	1	1			
-50~50C	-100~100F	1	1	0	0	1	1	1	0	1	0	1	1	1			
-50~100C	-100~200F	1	1	1	0	1	1	1	0	1	0	1	1	1			
-50~150C	-100~300F	1	0	0	1	1	1	1	0	1	0	1	1	1			
-100~100C	-200~200F	1	0	0	1	1	1	1	1	0	1	0	1	1			
-100~200C	-200~400F	1	1	0	1	1	1	1	1	0	1	0	1	1			
-200~200C	-400~400F	0	0	1	1	1	1	1	1	1	0	1	0	1			
-200~400C	-400~800F	1	0	1	1	1	1	1	1	1	0	1	0	1			
20~40C	40~80F	1	1	0	0	0	0	1	1	0	1	1	1	0			
50~100C	100~200F	1	1	1	0	0	1	1	0	1	0	1	1	0			
50~150C	100~300F	1	1	0	0	1	1	1	0	1	0	1	1	0			
100~200C	200~400F	1	1	0	0	1	1	1	1	0	1	0	1	0			
100~500C	200~1000F	0	0	1	1	1	1	1	1	0	1	0	1	0			

2100-M-V Input Programming.

If the input range is not listed in the programming table, use the following formulae to work out the Zero and Span switch Gain Values. Use the table at the top of the previous page to calculate DIP switch settings from the calculated gain values.

For V input: Span Gain = $\frac{40}{\text{signal high} - \text{signal low}}$

Zero Gain = signal low x 8

Note: Eg. Enter 2V as 2.

For mV input: Span Gain = $\frac{10,000}{\text{signal high} - \text{signal low}}$

Zero Gain = $\frac{\text{signal low}}{25}$

Note: Eg. Enter 200mV as 200.

Input Range Vdc	S2-Span						S3-Zero						S4-Function			
	1	2	3	4	5	6	1	2	3	4	5	6	1	2	3	4
0~200mV	1	1	1	0	1	0	1	1	1	1	1	1	X	0	X	Set to '0' for Binary Channel Selection. Set to '1' for Clock/Reset Channel Selection.
0~400mV	1	1	0	1	0	1	1	1	1	1	1	1	X	0	X	
0~500mV	1	1	1	1	0	1	1	1	1	1	1	1	X	0	X	
0~800mV	1	0	1	0	1	1	1	1	1	1	1	1	X	0	X	
0~1000mV	1	1	1	0	1	1	1	1	1	1	1	1	X	0	X	
0~1V	1	1	1	0	1	0	1	1	1	1	1	1	X	1	X	
0~2V	1	1	0	1	0	1	1	1	1	1	1	1	X	1	X	
0~2.5V	1	1	1	1	0	1	1	1	1	1	1	1	X	1	X	
0~4V	1	0	1	0	1	1	1	1	1	1	1	1	X	1	X	
0~5V	1	1	1	0	1	1	1	1	1	1	1	1	X	1	X	
0~8V	0	1	0	1	1	1	1	1	1	1	1	1	X	1	X	
0~10V	1	1	0	1	1	1	1	1	1	1	1	1	X	1	X	
100~500mV	1	1	0	1	0	1	1	1	0	1	1	1	0	0	X	
200~1000mV	1	0	1	0	1	1	1	1	0	1	1	1	0	0	X	
0.5~2.5V	1	1	0	1	0	1	1	1	0	1	1	1	0	1	X	
1~5V	1	0	1	0	1	1	1	1	0	1	1	1	0	1	X	
2~6V	1	0	1	0	1	1	1	1	1	0	1	1	0	1	X	
2~10V	0	1	0	1	1	1	1	1	1	0	1	1	0	1	X	
6~10V	1	0	1	0	1	1	1	1	1	0	0	1	0	1	X	

2100-M Output Programming.

Iout	Vout	S1-Output			
		1	2	3	4
4~20mA	2~10V	1	1	1	0
0~20mA	0~10V	0	0	0	0
2~10mA	1~5V	1	1	1	1
0~10mA	0~5V	0	0	1	1

2100-M H1 Power Supply Settings.

Power Supply Jumper Settings	
H1	Power Supply Voltage Range
H	Jumper for 85~264Vac/dc
M	Jumper for 23~90Vdc

- Note 1. Power must be OFF before changing H1's position.
- Note 2. Exceeding these parameters may damage the unit.
- Note 3. Ensure the enclosure label is correctly labelled for the jumper position.
- Note 4. Low Voltage Power Supply version is fixed, and has no jumper. This must be ordered separately.

Section C. Input and Output Connection Diagrams.

2100-M-I Input Connection Diagram for 4~20mA Inputs.

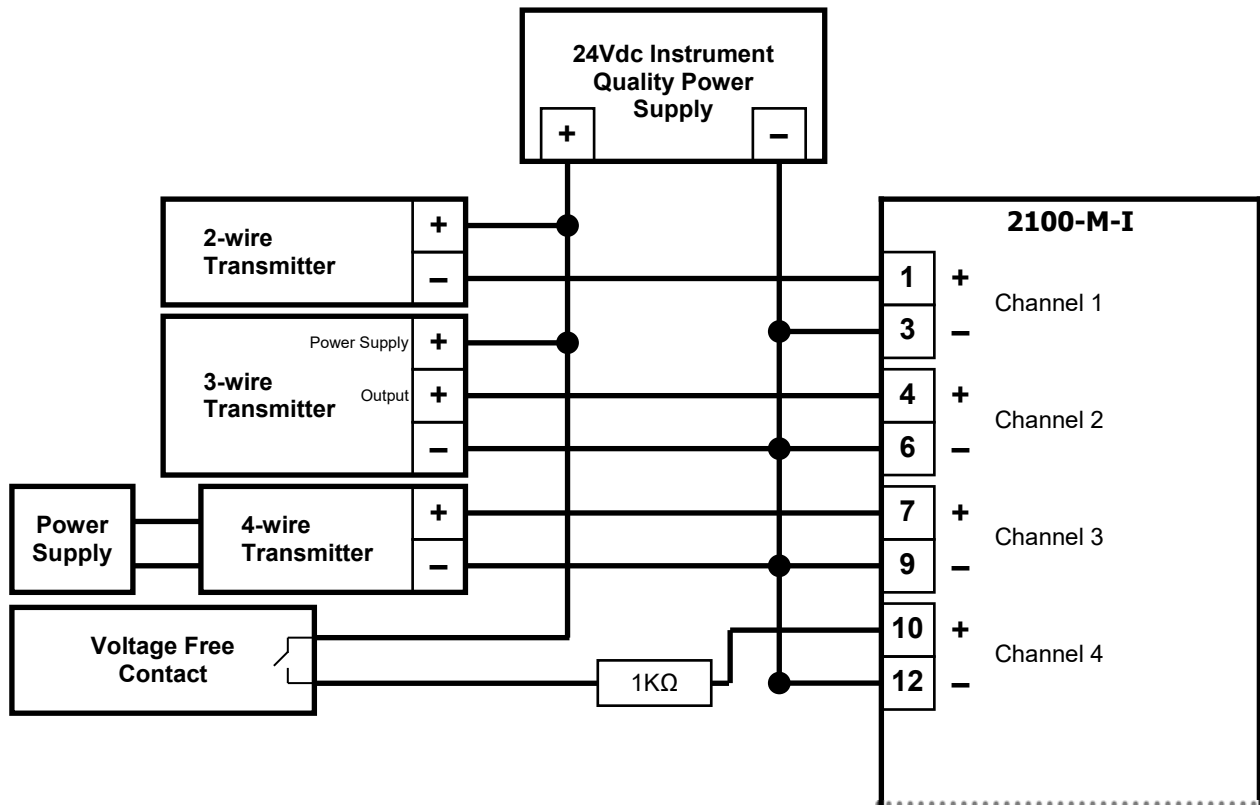

Connection configuration for 2 wire, 3 wire and 4 wire transmitters, and digital inputs.

Note 1. All 2100-M-I inputs are single ended. (ie, all negative inputs are internally connected.)

Note 2. Inputs can be used as digital inputs for sensing a clean, voltage free, field contact.

Note 3. All cables must be screened, and the screens earthed at one end only.

Important: Do not use the 2100-M power supply to power up any transmitter or other equipment. An external power supply must be used for this purpose. **The 15V supply is for Channel Selection only.**

2100-M-R Input Connection Diagram for RTD Inputs.

Note 1. Inputs can be used as digital inputs for sensing a clean, voltage free, field contact. S4-3 must be set to '0'. (Upscale sensor break.)

Note 2. All RTD cables must be screened, and the screens earthed at one end only. All the three wires must be the same resistance. (i.e. the same type and size.) Refer to 'Wiring and Installation' for recommended types.

Note 3. It is recommended that only 3-wire RTDs are used. If 2-wire RTDs are used, lead resistances will not be compensated for, causing a zero offset error.

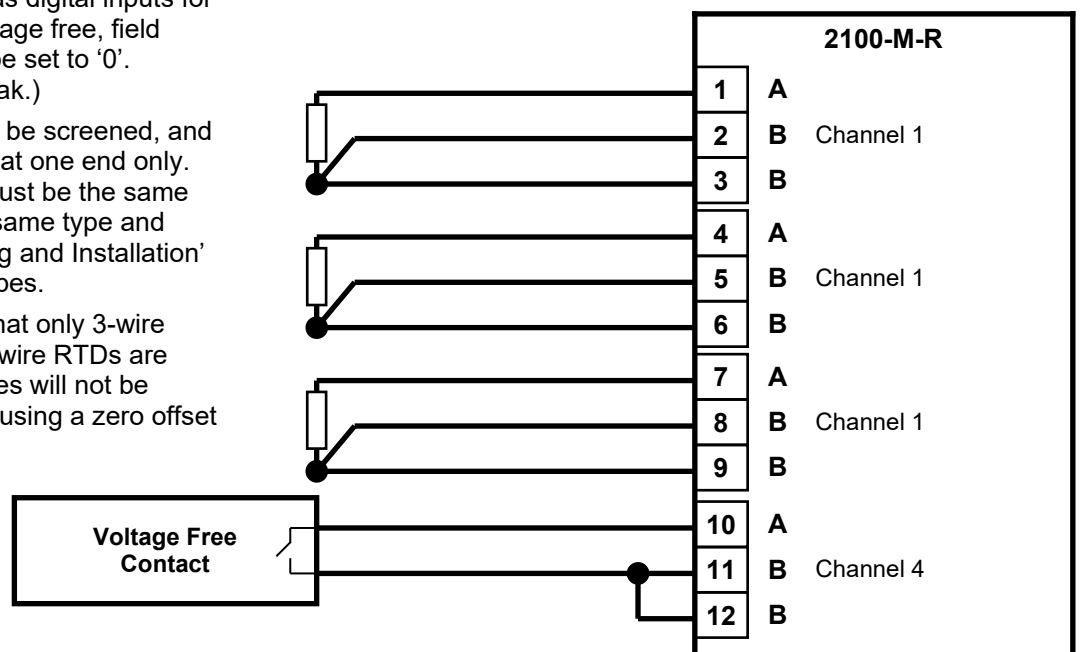

Important: All 2100-M-R inputs are single ended. i.e. all the 2nd 'B' terminals are internally connected.

2100-M-V Input Connection Diagram for Voltage Inputs.

Connection configuration for 3 wire and 4 wire transmitters, and digital inputs.

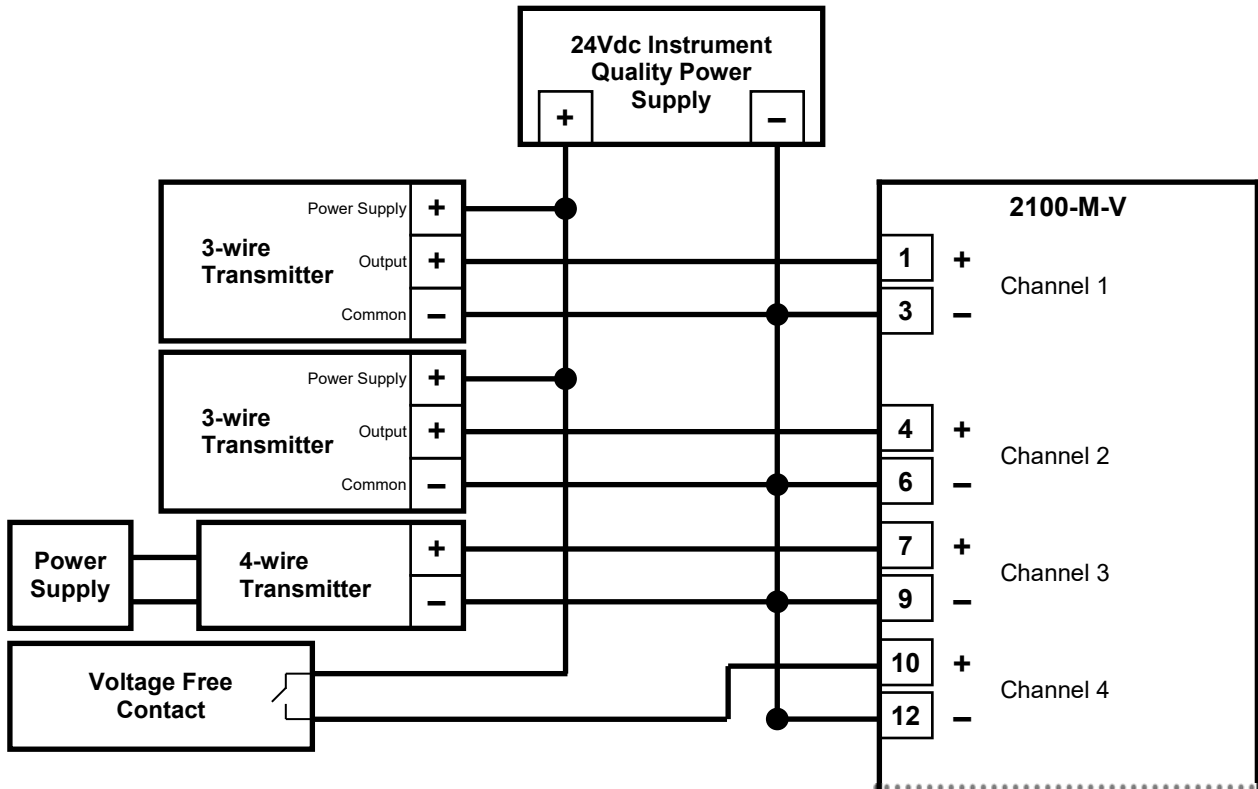

Note 1. All 2100-M-V inputs are single ended. (ie, all negative inputs are internally connected).

Note 2. Inputs can be used as digital inputs for sensing a clean, voltage free, field contact.

Note 3. All cables must be screened, and the screens earthed at one end only.

Important:

- Do not use the 2100-M power supply to power up any transmitter or other equipment. An external power supply must be used for this purpose. The 15V supply is for the Channel Selection only.
- Input voltages must not exceed 26V.

2100-M Connection Diagram Using an LPI-D Current Loop Isolator on the Input.

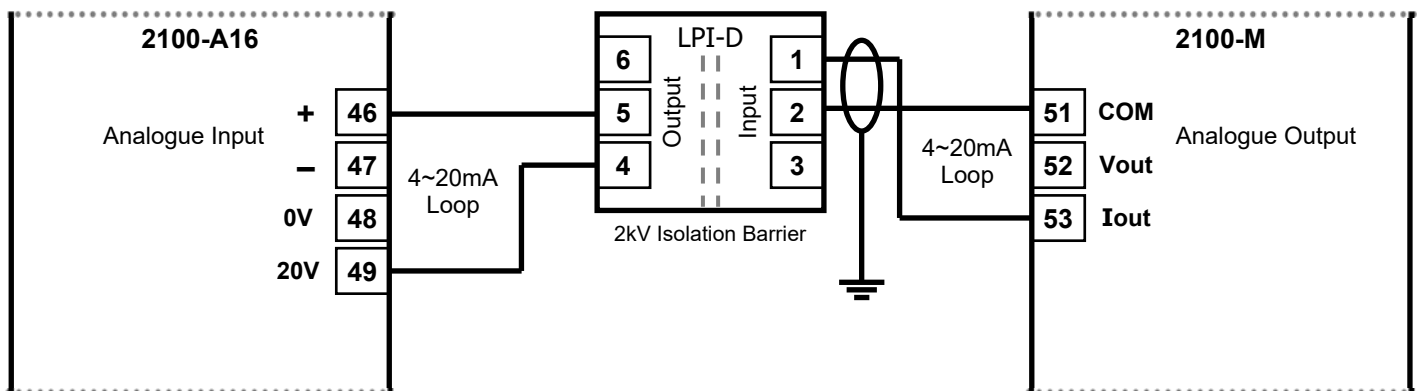

2100-M Connection Diagram Using an XI-P1 Current Loop Isolator on the Input.

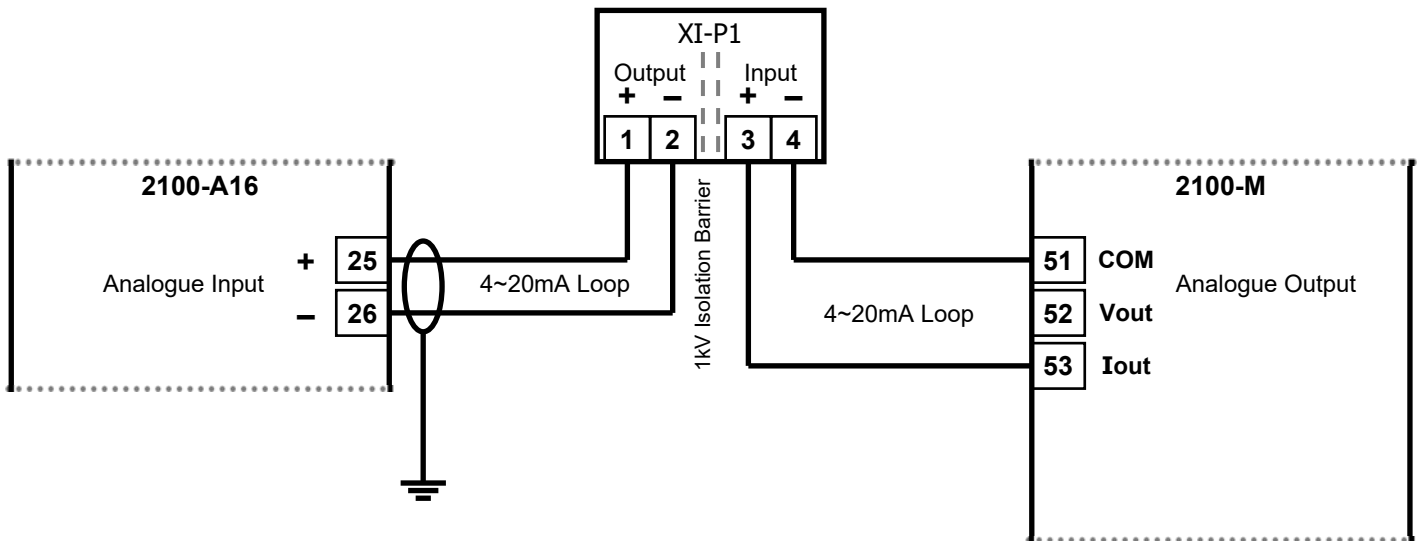

Section D. Connection to a MicroScan SCADA System.

2100-A16 Analogue Input Expansion - Using 2100-M Analogue Input Multiplexer.

Analogue input expansion can be achieved using up to four 2100-M, 16 Channel, Analogue Input Multiplexers. This gives a total of 76 analogue inputs. Control for the 2100-M is through the AO1 and AO2 on the 2100-A16. (Refer Note 4 below.) One analogue input is required per 2100-M, and each 2100-M input must be of the same type and range. The remaining 2100-A16 analogue inputs can be used for any other type of input.

Option 1. 5 Wire Connection Diagram.

This uses 5 wires for the first 2100-M, with 2 additional wires for each additional 2100-M. In this configuration the analogue inputs are differential. The maximum peak input voltage is 18V.

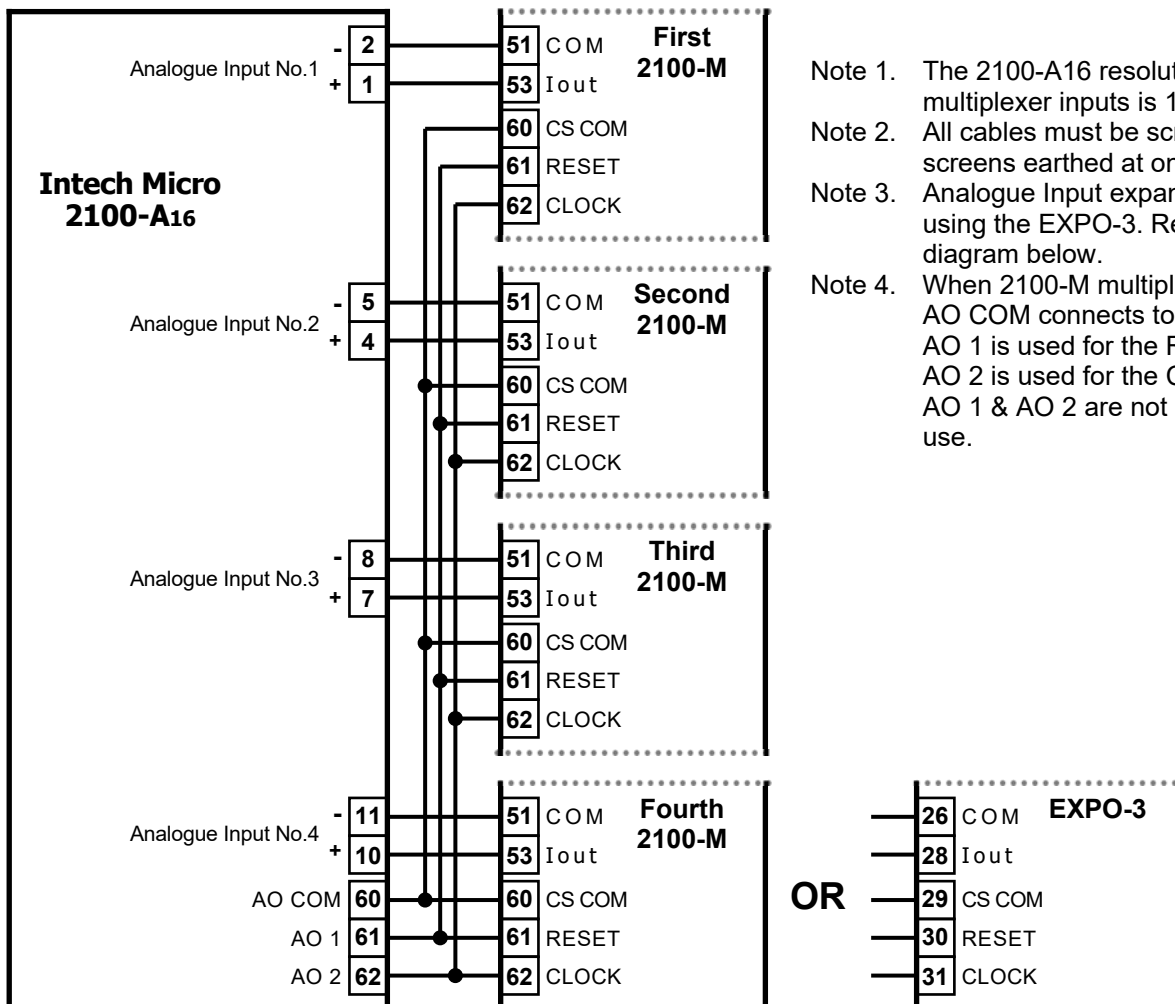

- Note 1. The 2100-A16 resolution on 2100-M multiplexer inputs is 12 bits (4096 steps)
- Note 2. All cables must be screened, and the screens earthed at one end only.
- Note 3. Analogue Input expansion is also possible using the EXPO-3. Refer to the connection diagram below.
- Note 4. When 2100-M multiplexers are used: AO COM connects to CS COM; AO 1 is used for the RESET pulse; AO 2 is used for the CLOCK pulse. AO 1 & AO 2 are not available for any other use.

Option 2. 4 Wire Connection Diagram.

This uses 4 wires (2 pair) for the first 2100-M, with 1 additional wire for each additional 2100-M. In this configuration the analogue inputs single ended. i.e. All the -ve inputs are all commoned.

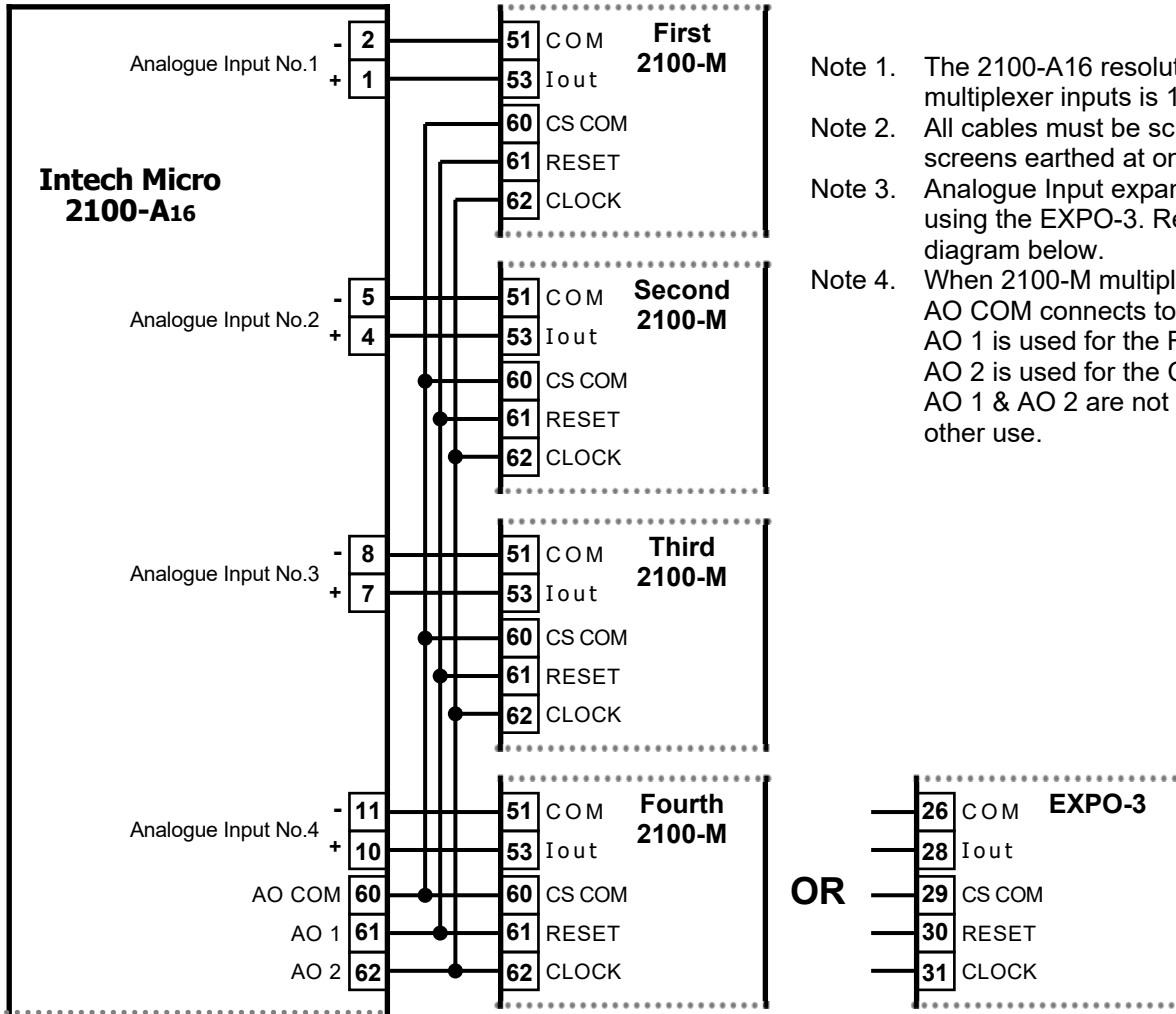

- Note 1. The 2100-A16 resolution on 2100-M multiplexer inputs is 12 bits (4096 steps)
- Note 2. All cables must be screened, and the screens earthed at one end only.
- Note 3. Analogue Input expansion is also possible using the EXPO-3. Refer to the connection diagram below.
- Note 4. When 2100-M multiplexers are used: AO COM connects to CS COM; AO 1 is used for the RESET pulse; AO 2 is used for the CLOCK pulse. AO 1 & AO 2 are not available for any other use.

OR

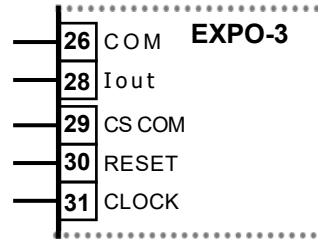

2100-M to IN-2000-AI Remote Station Connection Diagram.

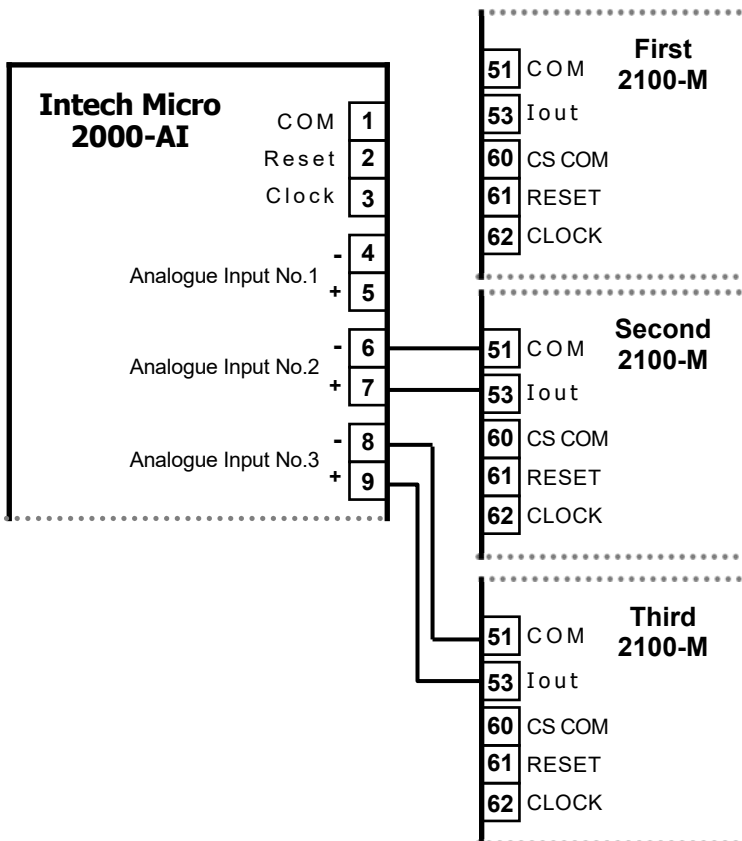

- Note 1. Up to three 2100-M multiplexers can be connected to one IN-2000-AI.
- Note 2. The remaining IN-2000-AI inputs (4 to 8) can be used for normal 4~20mA input signals.
- Note 3. All cables must be screened, and the screen earthed at one end only
- Important:** Do not use the 2100-M power supply to power up any transmitter or other equipment. An external power supply must be used for this purpose. The 15V supply is for the Channel Selection only.

Section E. Connecting to a PLC.

2100-M Clock/Reset Mode, PLC Installation Guide.

Specifications

Clocking speed	- Reset pulse length	20msec.
	- Clock pulse length	20msec.
Settling times before reading		100msec Min*.
		(Multiple readings with averaging recommended.)
Binary signal magnitude	- All models	6~40Vdc Min*.

*Longer times may be required for longer cable lengths and higher resolution.

Sequence:

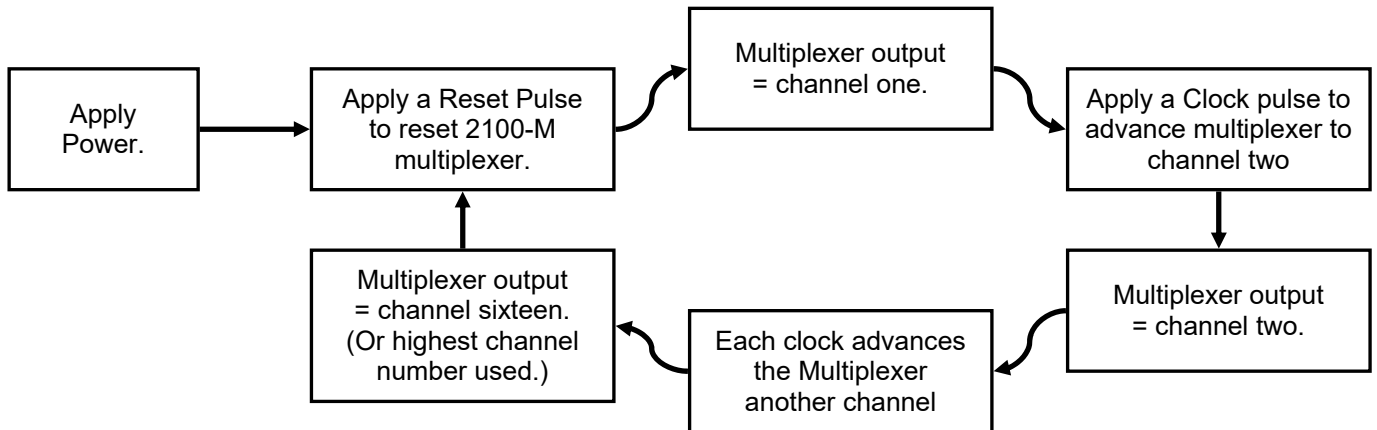

Operation:

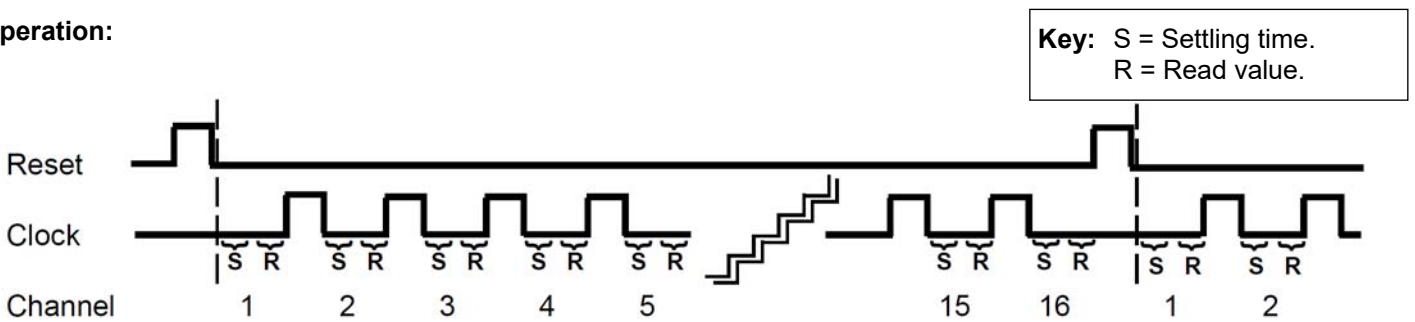

2100-M Binary Channel Selection Mode, PLC installation Guide.

Specifications

Settling times before reading	- All models	100msec Min*.
		(Multiple readings with averaging recommended.)
Binary signal magnitude	- All models	6~40Vdc Min*.

*Longer times may be required for longer cable lengths and higher resolution.

2100-M Binary Channel Selection Mode Table.

Terminal Number				2100-M Channel Selected
61-Bin1	62-Bin2	63-Bin4	64-Bin8	
0	0	0	0	1
1	0	0	0	2
0	1	0	0	3
1	1	0	0	4
0	0	1	0	5
1	0	1	0	6
0	1	1	0	7
1	1	1	0	8
0	0	0	1	9
1	0	0	1	10
0	1	0	1	11
1	1	0	1	12
0	0	1	1	13
1	0	1	1	14
0	1	1	1	15
1	1	1	1	16

Notes

- '0' = no voltage on the terminal.
'1' = 6~40Vdc on the terminal.
- Ensure that if the analogue output from each 2100-M is fed into the same unit (eg PLC), then it is recommended the analogue inputs to the PLC, etc, be isolated.

2100-M to PLC Connection Diagram Using External Power Supply and 24V Common Open Collectors.

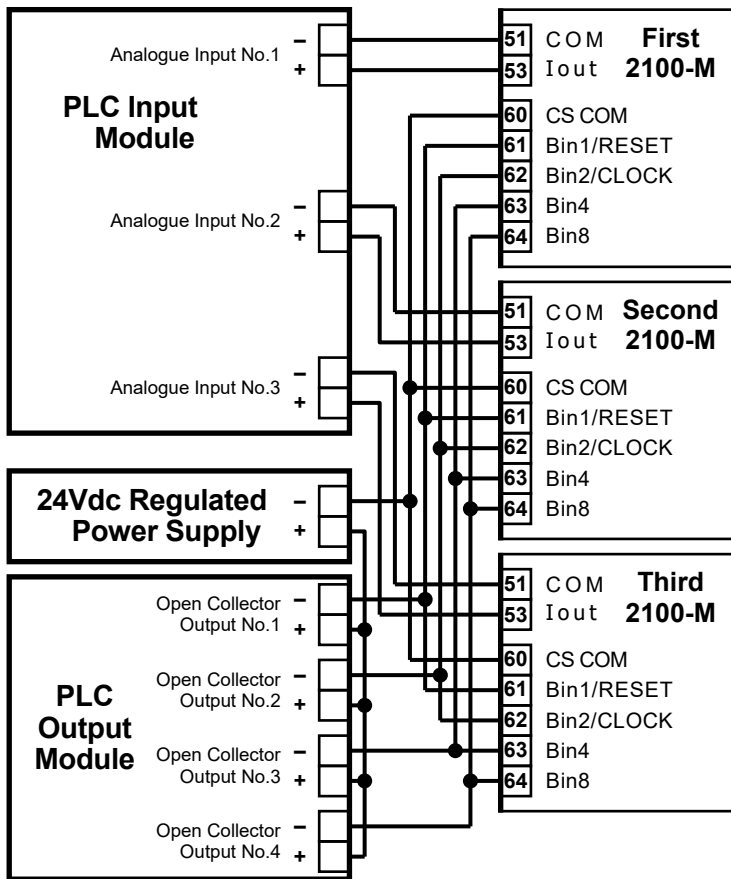

Connection of a 2100-M to a PLC with open collectors, commoned to +24V of an external power supply.

Note 1. In this configuration the 2100-M CS COM and Channel Selection inputs are isolated from the 2100-M inputs and outputs. The 24V external power supply can therefore be used to power transmitters connected to the 2100-M inputs.

Note 2. There is no limit to the number of 2100-Ms that can be connected, except the power supply and open collector outputs must be able to handle the load.

Note 3. Each Channel Selection input draws 9mA at 24Vdc.

Note 4. All cables must be screened, and the screens earthed at one end only.

Note 5. For Clock/Reset Channel Selection DO NOT connect PLC outputs 3 and 4 to Bin 4 and Bin 8 of the 2100-M.

Important: Do not use the 2100-M power supply to power up any transmitter or other equipment. An external power supply must be used for this purpose. The 15V supply is for the Channel Selection only.

2100-M to PLC Connection Diagram Using 2100-M Power Supply and 15V Common Open Collectors.

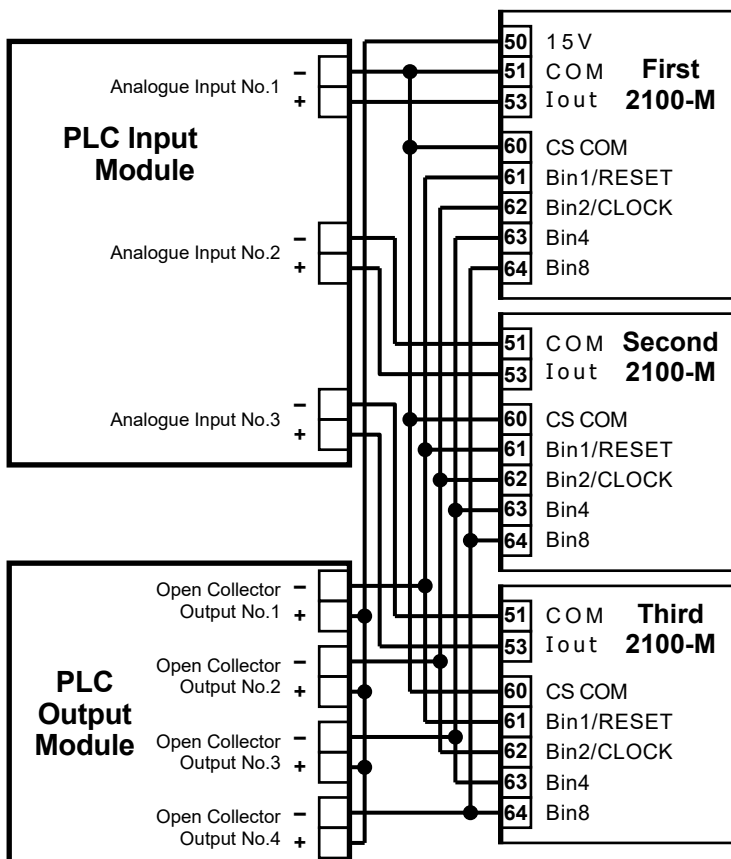

Connection of a 2100-M to a PLC with open collectors, commoned to the 15V of the first 2100-M power supply.

Note 1. Using this configuration, up to eight 2100-Ms can be connected using Clock/Reset mode, or four using Binary Channel Selection mode, provided the open collector outputs can handle the load.

Note 2. Each Reset and each Clock input draws 5mA at 15Vdc.

Note 3. All cables must be screened, and the screens earthed at one end only.

Note 4. For Clock/Reset Channel Selection DO NOT connect PLC outputs 3 and 4 to Bin 4 and Bin 8 of the 2100-M.

Important: Do not use the 2100-M power supply to power up any transmitter or other equipment. An external power supply must be used for this purpose. The 15V supply is for the Channel Selection only.

2100-M Rev.1 to PLC Connection Diagram Using External Power Supply and 0V Common Open Collectors.

Note: This diagram only applies to the 2100-M Rev.1. For 2100-M Rev.0 refer next page.

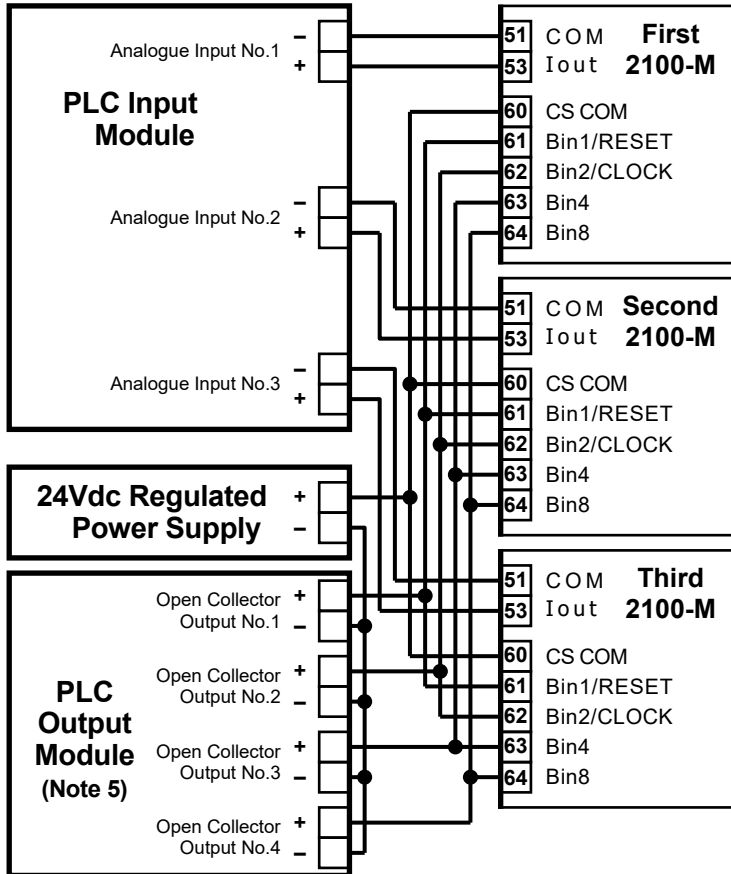

Connection of a 2100-M to a PLC with open collectors, commoned to +24V of an external power supply.

- Note 1. In this configuration the 2100-M CS COM and Channel Selection inputs are isolated from the 2100-M inputs and outputs. The 24V external power supply can therefore be used to power transmitters connected to the 2100-M inputs.
- Note 2. There is no limit to the number of 2100-Ms that can be connected, except the power supply and open collector outputs must be able to handle the load.
- Note 3. Each Channel Selection input draws 9mA at 24Vdc.
- Note 4. All cables must be screened, and the screens earthed at one end only.
- Note 5. For Clock/Reset Channel Selection DO NOT connect PLC outputs 3 and 4 to Bin 4 and Bin 8 of the 2100-M.
- Note 6. For 2100-M Rev.1 channel selection inputs are bi-directional. CS-COM can be connected to either the positive or negative of the supply.

Important: Do not use the 2100-M power supply to power up any transmitter or other equipment. An external power supply must be used for this purpose. The 15V supply is for the Channel Selection only.

2100-M Rev.1 to PLC Connection Diagram Using 2100-M Rev.1 Power Supply and 0V Common Open Collectors.

Note: This diagram only applies to the 2100-M Rev.1. For 2100-M Rev.0 refer next page.

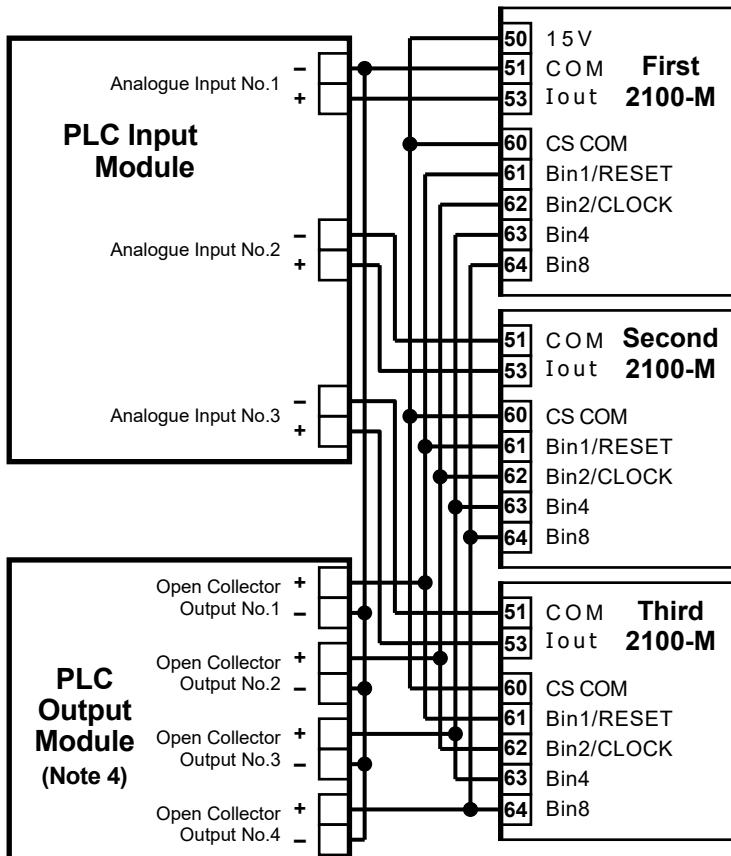

Connection of a 2100-M to a PLC with open collectors, commoned to the 15V of the first 2100-M power supply.

- Note 1. Using this configuration, up to eight 2100-Ms can be connected using Clock/Reset mode, or four using Binary Channel Selection mode, provided the open collector outputs can handle the load.
- Note 2. Each Reset and each Clock input draws 5mA at 15Vdc.
- Note 3. All cables must be screened, and the screens earthed at one end only.
- Note 4. For Clock/Reset Channel Selection DO NOT connect PLC outputs 3 and 4 to Bin 4 and Bin 8 of the 2100-M.
- Note 5. For 2100-M Rev.1 channel selection inputs are bi-directional. CS-COM can be connected to either the positive or negative of the supply.

Important: Do not use the 2100-M power supply to power up any transmitter or other equipment. An external power supply must be used for this purpose. The 15V supply is for the Channel Selection only.

2100-M Rev.0 to PLC Connection Diagram Using External Power Supply and 0V Common Open Collectors.

Note: This diagram only applies to the 2100-M Rev.0. For 2100-M Rev.1 refer previous page.

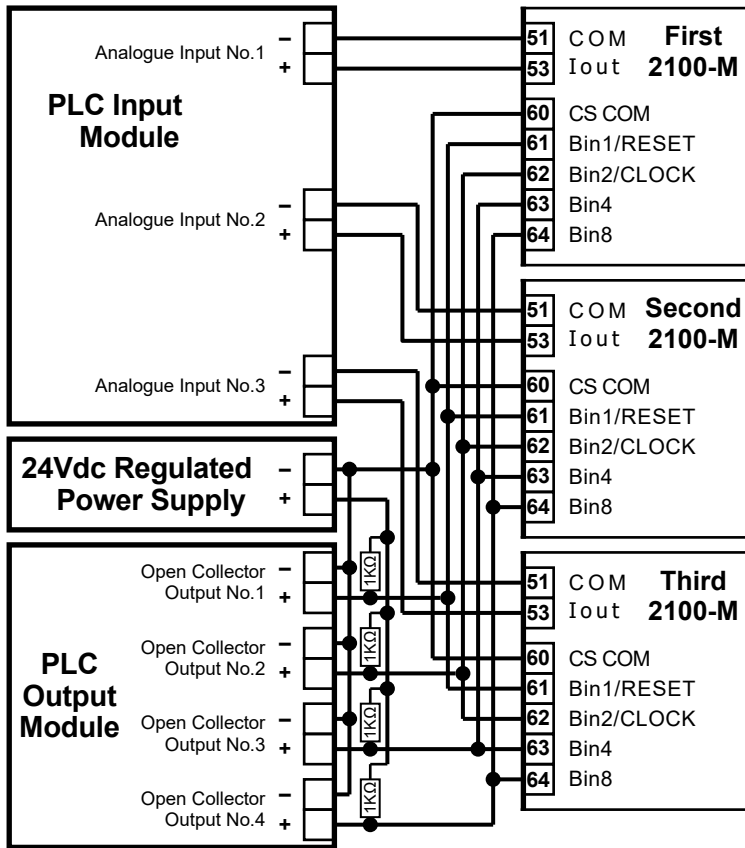

Connection of a 2100-M to a PLC with open collectors commoned to 0V of an external power supply.

- Note 1. This configuration reverses the logic so when the PLC digital output is off, the 2100-M is on.
- Note 2. With 1kΩ resistor, up to four 2100-Ms can be connected in this configuration, provided the open collector outputs can handle the load.
- Note 3. Each Channel Selection input draws 10mA at 24Vdc.
- Note 4. All cables must be screened, and the screens earthed at one end only.
- Note 5. For Clock/Reset Channel Selection DO NOT connect PLC outputs 3 and 4 to Bin 4 and Bin 8 of the 2100-M.

Important: Do not use the 2100-M power supply to power up any transmitter or other equipment. An external power supply must be used for this purpose. The 15V supply is for the Channel Selection only.

2100-M Rev.0 to PLC Connection Diagram Using 2100-M Power Supply and 0V Common Open Collectors.

Note: This diagram only applies to the 2100-M Rev.0. For 2100-M Rev.1 refer previous page.

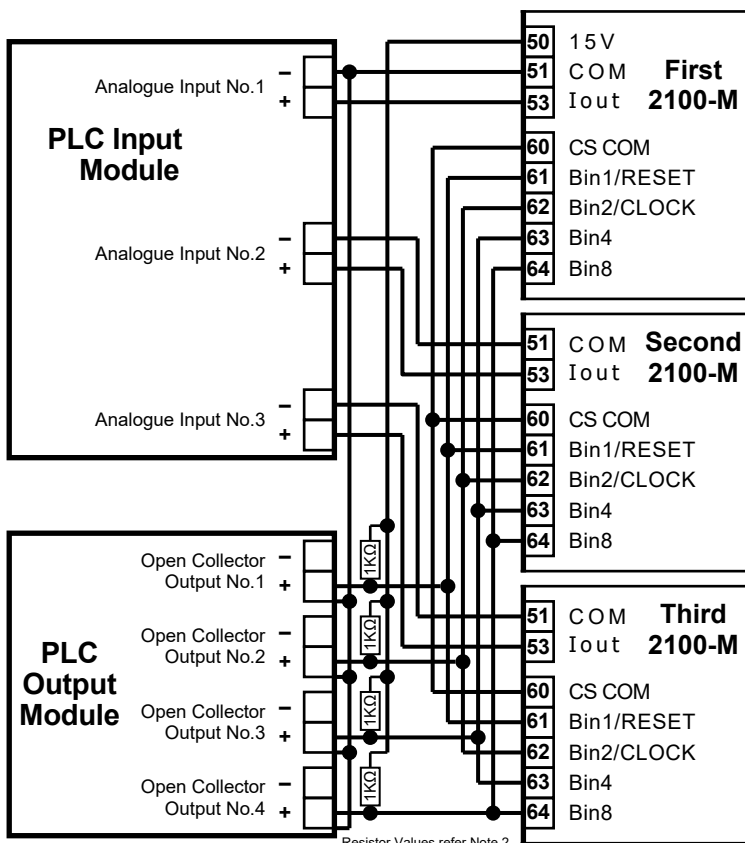

Connection of a 2100-M to a PLC with open collectors commoned to COM of the first 2100-M.

- Note 1. This configuration reverses the logic so when the PLC digital output is off, the 2100-M is on.
- Note 2. For Clock/Reset Channel Selection the resistors = **1kΩ**. Up to four 2100-Ms can be connected in this configuration provided the open collectors can handle the load. For Binary Channel Selection the resistor = **2.2kΩ**. Up to two 2100-Ms can be connected in this configuration provided the open collectors can handle the load.
- Note 3. All cables must be screened, and the screens earthed at one end only.
- Note 4. For Clock/Reset Channel Selection DO NOT connect PLC outputs 3 and 4 to Bin 4 and Bin 8 of the 2100-M.

Important: Do not use the 2100-M power supply to power up any transmitter or other equipment. An external power supply must be used for this purpose. The 15V supply is for the Channel Selection only.

Resistor Values refer Note 2.

Analogue Signal Converted to Frequency for a PLC, using a TWI-FO.

Description.

The TWI-FO converts 4~20mA from a 2100-M to a frequency output. (Typically 10~1010Hz, but this is rangable.) A PLC with two digital outputs and one digital input can receive sixteen multiplexed inputs.

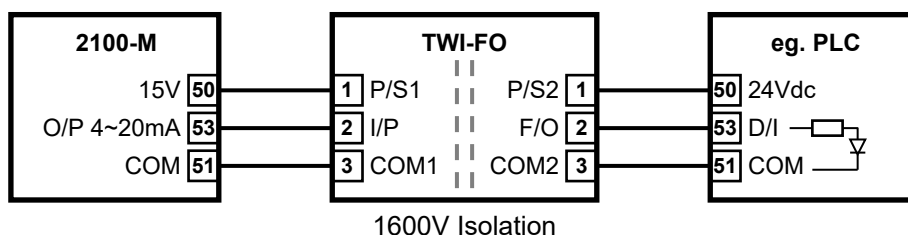

Section F. Wiring, Installation and Maintenance.

THE 2100-M IS TO BE INSTALLED AND SERVICED BY SERVICE PERSONNEL ONLY. NO OPERATOR / USER SERVICABLE PARTS.

All power and signals must be de-energised before connecting any wiring, or altering any Jumpers or Dip Switches.

Mounting.

* Also refer to Connection Diagrams and Notes.

- (1) Mount in a clean environment in an electrical cabinet on 35mm Symmetrical mounting rail.
- (2) Draft holes must have minimum free air space of 20mm. Foreign matter must not enter or block draft holes.
- (3) Do not subject to vibration or excess temperature or humidity variations.
- (4) Avoid mounting in cabinets with power control equipment.
- (5) To maintain compliance with the EMC Directives the 2100-M is to be mounted in a fully enclosed steel fire cabinet. The cabinet must be properly earthed, with appropriate input / output entry points and cabling.

Cover Removal and Fitting.

To remove 2100 covers, firmly push down the button in the middle of one endplate, and pull the end plate outwards, while pulling the cover up and out.

To fit the cover, first make sure the cover is being fitted the correct way around, (Terminal 82 on the cover is above 82 on the board.) and that the serial number on the board matches the serial number on the cover (if applicable). Slide one end of the cover into the slot in the endplate. Pull the other endplate outwards and push the cover down until it slides into the slot of this endplate. Check both ends are firmly held.

Wiring.

- (1) A readily accessible disconnect device and a 1A, 250Vac overcurrent device, must be in the power supply wiring.
- (2) For power supply, connect Phase (or +Ve) to terminal 82, Neutral (or -Ve) to 81, and Earth to 80. To ensure compliance to CE Safety requirements, the grey terminal insulators must be fitted to ALL mains terminals after wiring is completed. (ie. terminals 82, 81 and 80.) For Non Hazardous Voltage power supplies (not exceeding 42.4Vpeak or 60Vdc) terminals 81 and 80 may be linked together, instead of connecting an earth.
- (3) All signal cables should be good quality overall screened INSTRUMENTATION CABLE with the screen earthed at one end only.
- (4) Signal cables should be laid a minimum distance of 300mm from any power cables.
- (5) For 2 wire current loops, 2 wire voltage signals or 2 wire current signals, Austral Standard Cables B5102ES is recommended. For 3 wire transmitters and RTDs Austral Standard Cables B5103ES is recommended.
- (6) It is recommended that you do not ground current loops and use power supplies with ungrounded outputs.
- (7) Lightning arrestors should be used when there is a danger from this source.
- (8) Refer to diagrams for connection information.

2100-M-R RTD'S.

- (1) Avoid locating the RTD where it will be in a direct flame.
- (2) Locate it where the average temperature will be measured. It should be representative of the mass.
- (3) Immerse the RTD far enough so that the measuring point is entirely in the temperature to be measured; nine to ten times the diameter of the protection tube is recommended. Heat that is conducted away from the measuring point causes an error in reading.

2100-M Commissioning.

- (1)
 - a) Check that the 2100-M has been set up to the right input and output ranges, and that it's new ranges have been calibrated accurately and checked. DIP switch settings will normally be accurate to 1%. (This can be greater for smaller ranges.
 - b) Use the Zero and Span Pots in the 2100-M to finely calibrate the desired range. Using a small screwdriver turn the Pots clockwise to increase the output, and anticlockwise to decrease the output.
Note: Do not adjust the NULL Pot. This is factory set.
- (2) Once all the above conditions have been met, and the wiring checked, apply power to the 2100-M, the loops or sensors, and the IN-2000AI or PLC etc. controlling the 2100-M. Allow a 5 minute warm-up period.
- (3) For Clock/Reset Channel Selection only:
Check that the red LEDs on the 2100-M are flashing. The LED next to the Clock terminal (62) should flash 16 times faster than the LED next to the Reset terminal (61). For each Clock or Reset pulse received the respective LED on the 2100-M will go from OFF to ON to OFF. If a Clock or Reset line is held high, the respective LED will remain ON. If a Clock or Reset line is held low, the respective LED will remain OFF.
For Binary Channel Selection only:
Use the table on page 15.01-11 to determine which LEDs should be on. Eg. If Channel 8 is selected the LEDs next to Bin1 terminal (61), Bin2 terminal (62), and Bin3 terminal (63) should be ON, and the LED next to Bin4 terminal (64) should be OFF. The LEDs will remain on while the selected channel is being read.
- (4) Take a reading of the value being measured on each channel, and ensure that this agrees with the level being indicated by the IN-2000-AI, Data Logger, or PLC, for that channel. Adjust for any differences in the software of the system, unless there is a constant error shift in each channel. In which case the Zero and Span Pots on the 2100-M can adjust for the constant error.

Note. 2100-M-R: A small error can occur due to differences in cable resistance in the RTD legs, and errors in the RTD itself. (Usually less than 0.5C). To check the variable being measured use a calibration standard RTD at the same immersion depth. If the Zero error is large, the readings are fluctuating or a Zero error has suddenly appeared after the 2100-M has been operating for some time, there could be an earth loop between two or more RTD sensors on the 2100-M-R (or between other commoned 2100-M-Rs). Disconnect each RTD sensor individually from the 2100-M-R, and 'Megger' the RTD by shorting all three wires together and testing from this point to earth. If a path to earth is found repair or replace the faulty RTD sensor or probe.

Warning: Do not 'Megger' the RTDs while connected to the 2100-M-R. Damage to the 2100-M-R will result.

2100-M Maintenance.

2100-M-I and 2100-M-V.

- (1) Repeat (4) of commissioning. Do it regularly - at least once every twelve months.

2100-M-R.

- (1) Repeat (4) of commissioning. Do it regularly - at least once every six months.
- (2) Replace defective protection tubes - even if they look good they may not be air or gas tight.
- (3) Check cables entering the RTD sensor head.

Intech[®]
instruments

www.intech.co.nz

Christchurch Ph: +64 3 343 0646

Auckland Ph: 09 827 1930

Email: sales@intech.co.nz

2100-M-r1 221221