

JUMO ecoTRANS Lf 01/02

Transmitter/Switching Device for Conductivity



Operating Manual



20273100T90Z002K000

V7.00/EN/00435548/2020-10-15

1	Notes	5
2	Identifying the device version	6
2.1	Type designation	6
3	Mounting	7
4	Electrical connection	7
5	Electrical connection	9
6	Commissioning	12
6.1	Fundamentals of conductivity measurement	12
6.2	Applying the supply voltage	12
6.3	Altering the device functions	13
6.3.1	Operation through the Setup	14
6.3.2	Operation through the teach-in connector (type 202731/02... only)	16
6.4	Calibration	18
6.4.1	Characteristics of sensor and medium	19
6.4.2	Preparing to calibrate the cell constant or the temperature coefficient	20
6.4.3	Calibrating the cell constant	21
6.4.4	Calibrating the temperature coefficient	21
6.5	Manual entry of temperature coefficient and cell constant	23
6.6	Manual mode	24
6.7	Analog output (type 202731/01...)	25
6.8	Relay output (type 202731/02...)	27
6.9	LED messages	29
7	Technical data	30
7.1	General characteristics	32
8	Environment/waste disposal	33
9	China RoHS	34

Content

1 Notes



To protect the device from electrostatic discharge, users must discharge themselves electrostatically before touching the device !

All necessary settings are described in these Operating Instructions. However, if any difficulties should still arise during start-up, please do not carry out any manipulations on the unit. You could endanger your rights under the device warranty! Please contact the nearest subsidiary or the head office in such a case.

Please read these operating instructions before starting up the device. Keep the manual in a place which is accessible to all users at all times. Please assist us to improve these operating instructions, where necessary.

2 Identifying the device version

The nameplate with the order code is glued to the side of the housing. The supply voltage must correspond to the voltage given on the nameplate.

2.1 Type designation

(1) Basic type	
202731	Microprocessor transmitter/switching device for conductivity
(2) Output	
01	with analog output
02	with relay output
(3) Measuring range^a	
015	0 – 2 mS/cm/K = 1.0 $1/cm^b$
016	0 – 20 mS/cm/K = 1.0 $1/cm^c$
(4) Extra codes	
000	none
024	including PC setup software

^a Possible measuring ranges see Chapter 7 „Technical data“, page 30, setting see Chapter 6.3 „Altering the device functions“, page 13

^b The standard measuring range, set in the factory, for type 202731/01

^c The standard measuring range, set in the factory, for type 202731/02

	(1)		(2)		(3)		(4)
Order code	<input type="text"/>	/	<input type="text"/>	-	<input type="text"/>	/	<input type="text"/>
Order example	202731	/	01	-	015	/	000

3 Mounting

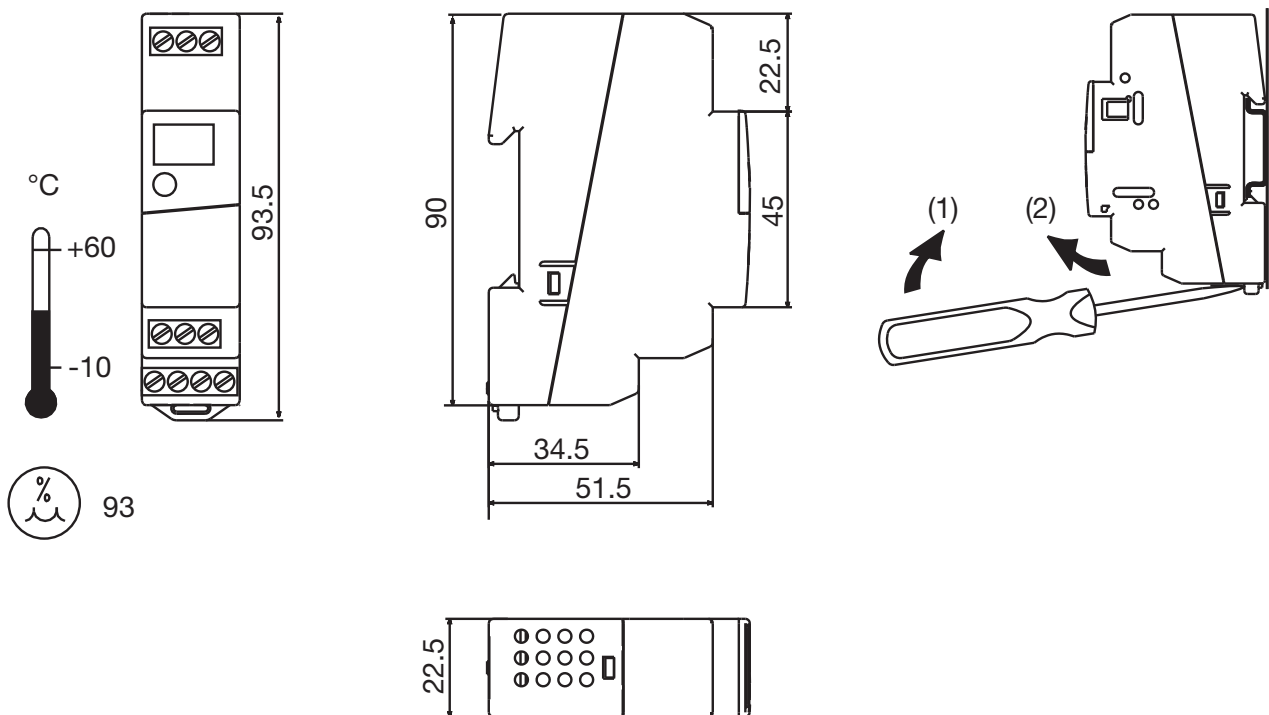

4 Electrical connection

The choice of cable, the installation, the fusing and the electrical connection must conform to the requirements of VDE 0100 “Regulations on the Installation of Power Circuits with Nominal Voltages below 1000 V” or the appropriate local regulations.

- To protect the device from electrostatic discharge, users must discharge themselves electrostatically before touching the device!
- The electrical connection must only be carried out by qualified personnel.
- Electromagnetic compatibility conforms to the standards and regulations cited in the technical data.
- The device may only be used on SELV or PELV electrical circuits.
- The device is **not** suitable for use in areas with an explosion hazard (Ex areas).

Apart from faulty installation, incorrect settings on the device may

also affect the proper functioning of the subsequent process or lead to damage. Safety devices should always be provided that are independent of the device (such as overpressure valves or temperature monitors/limiters) and only capable of adjustment by specialist personnel. Please observe the relevant safety regulations for such matters.

- The load circuit must be fused for the maximum relay current, in order to prevent the output relay contacts becoming welded in the event of a short circuit.
- Do not connect any additional loads to the screw terminals for the supply of the device.
- Any electrical connection other than that specified in the connection diagram may result in the destruction of the device.
- Run input, output and supply cables separately and not parallel to one another.
- Sensor leads must only be implemented as twisted and shielded, uninterrupted cables (**not** routed via terminal blocks etc).
- Supply fluctuations are only permissible within the specified tolerances (see Data Sheet 202731, page 3/6).



The supply voltage must be fed to the device with a 200 mA semiconductor fuse, semi time-lag, or an equivalent protection using a separate branch.

5 Electrical connection

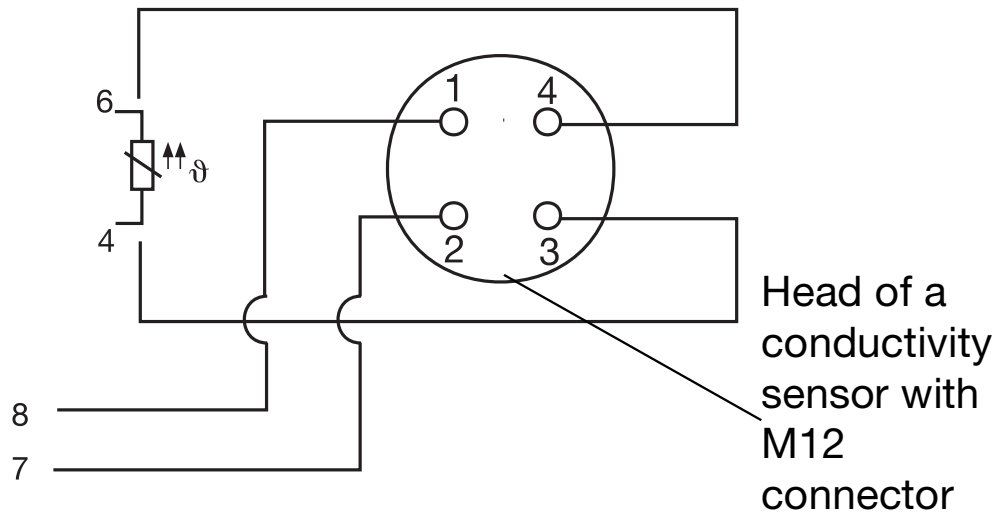
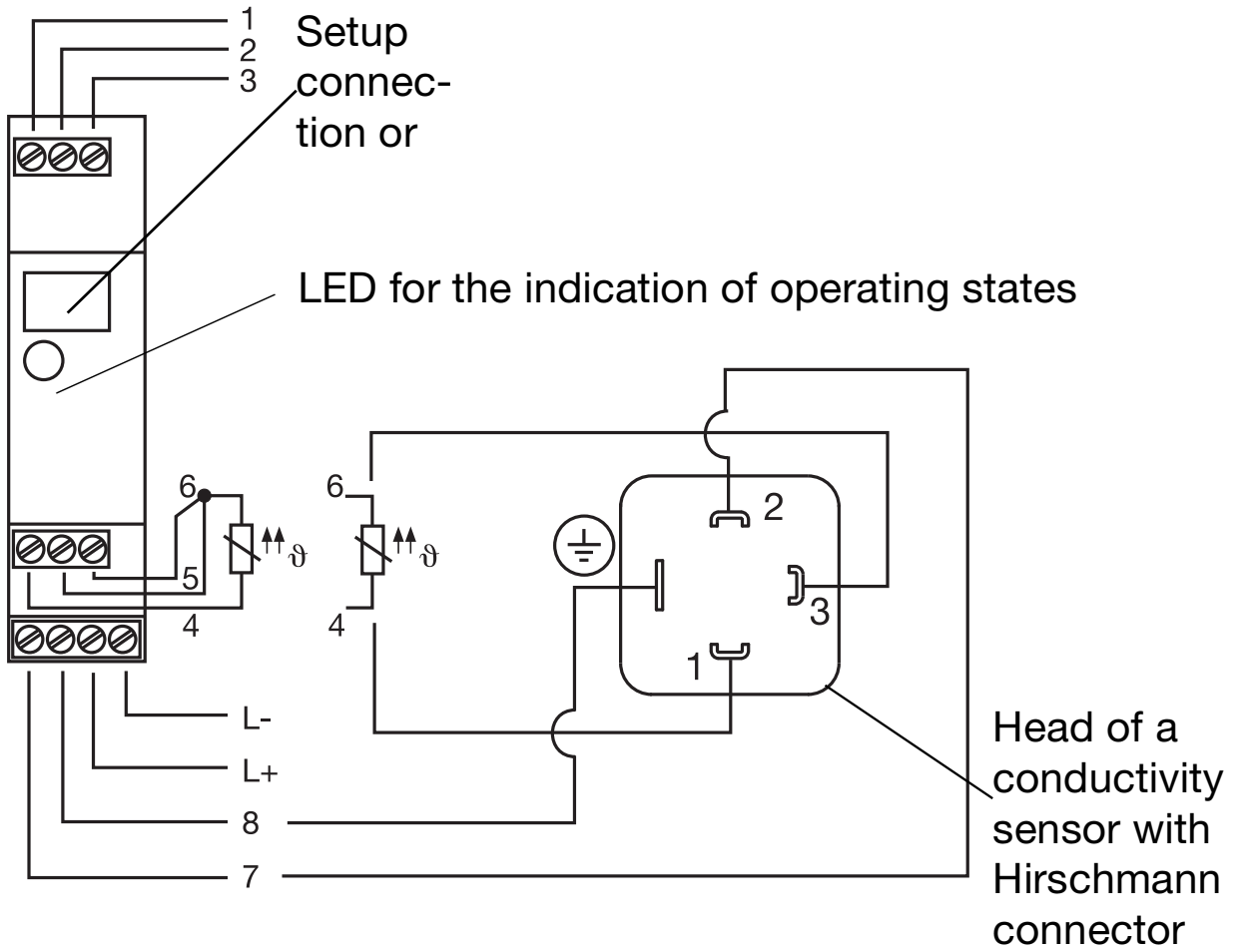

Connection of conductivity sensor

	Conductivity sensor		Type 202731/01... and type 202731/02....
	Angled connector to DIN 43 650 (Hirschmann connector)	Fixed cable	
Outer electrode	⊕	white	1 8
Inner electrode	2	brown	2 7
Temperature com- pensation	1 3	yellow green	3 4 6

Outputs	Terminal assignments		Symbol
Analog measurement output (electrically isolated) only with type 202731/01...	1 3	+ -	
Relay only with type 202731/02...	1 2 3	n.c. (break) common n.o. (make)	
Measurement inputs			
Conductivity sensor	8 7	outer electrode, on coaxial cells inner electrode, on coaxial cells	
Resistance thermometer in 3-wire circuit	4 5 6		
Resistance thermometer in 2-wire circuit	4 6		
Supply voltage			
Supply voltage (with reverse polarity protection) DC 20 to 30 V	L- L +		

6 Commissioning

6.1 Fundamentals of conductivity measurement

Principle of measurement

Electrolytic conductivity measuring cells basically consist of two metal plates arranged opposite each other which are immersed in the solution to be measured. The conductivity of the solution is determined through the measuring voltage and the resulting measuring current.

The current between the metal plates depends on their geometry (distance and area). The **cell constant** describes this dependence. Subject to manufacturing tolerances, or because of dirt or wear, the actual cell constant of a measuring cell may deviate slightly from its nominal value. This deviation is reflected by the **relative cell constant** that is adjustable on the conductivity transmitter.

The conductivity of a solution depends on temperature. The **temperature coefficient** of the solution describes the dependence of conductivity and temperature. Since conductivity is not always measured at the reference temperature, the temperature coefficient can be adjusted on the conductivity transmitter.

6.2 Applying the supply voltage

If the device has been connected correctly, the LED¹ will light up.

- green, constant status display
- red, constant the relay is active
(only on type 202731/02...)
- red, flashing alarm
 - measuring range infringed (overrange)
 - temperature range infringed (over/underrange)
 - temperature probe not connected correctly

¹ also see Chapter 6.9 „LED messages“, page 29

6.3 Altering the device functions

Alterations can only be carried out in the setup program.

Exception: the switching point of the type 202731/02... can also be determined by the device, through the teach-in connector.

Operation via the setup interface

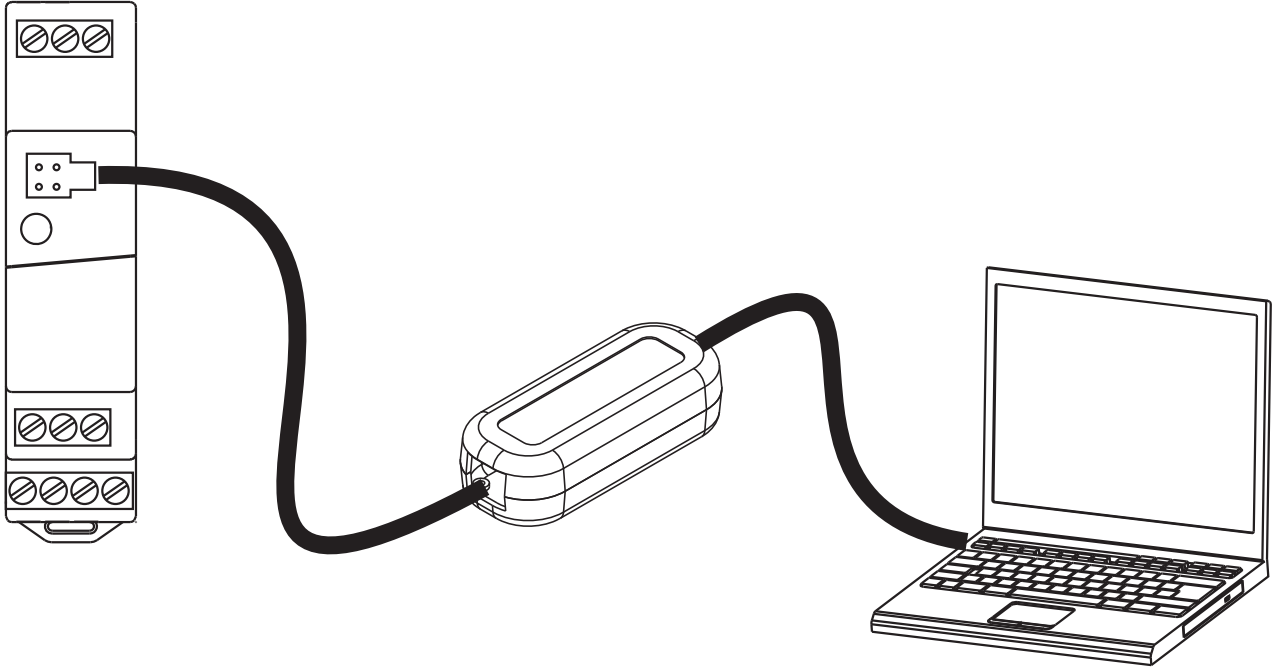

Caution

The setup interface and the measurement inputs for conductivity and temperature are connected electrically. This means that, in unfavorable conditions, equalizing currents may flow when the PC interface is connected. These equalizing currents may result in damage to the devices connected.

However, there is no danger if the measurement circuit of the transmitter is electrically isolated from ground. If this is not assured, then one of the following safety measures should be taken:

- 1) Use a computer without electrical coupling to ground (e.g. battery-operated notebook).
The computer must not be connected to a network.
- 2) Disconnect the measurement inputs of the transmitter before connecting the PC interface.

6.3.1 Operation through the Setup

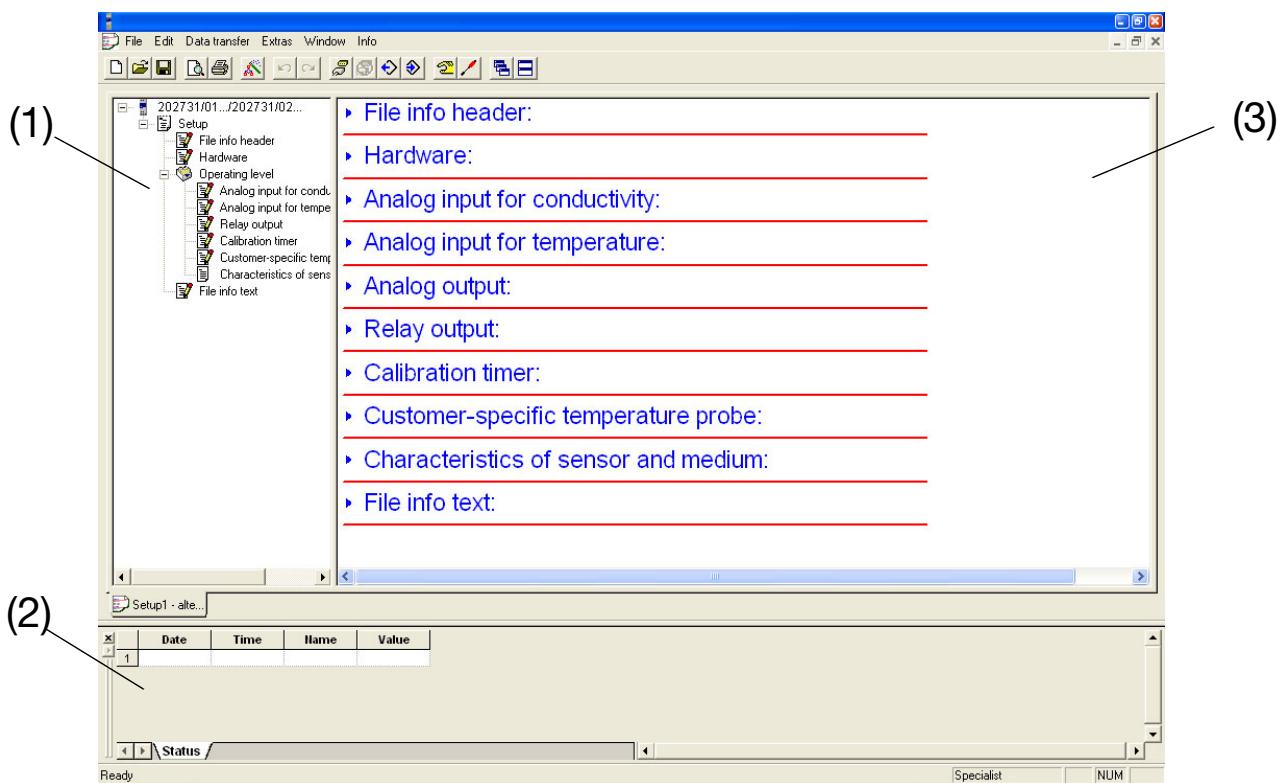

(1)	Navigation tree The navigation tree allows quick access (double-click) to the individual setting options.
(2)	Diagnosis window As soon as a connection with a device has been established, the latest data are shown here.
(3)	Working area If you click on the arrow (▶), the setting options will be shown. A double-click on the text will call up the corresponding editing window.

Analog input: Conductivity

In this window, you will be able to make settings with respect to the conductivity input.

Lead compensation:

The effect of long cables can be compensated on ranges above about 20 mS/cm by entering the lead resistance. This is done by entering the sum of the resistances for the incoming/return cables.

Analog input: Temperature

In this window, you can make settings with respect to the temperature input, such as probe type, connection circuit (e.g. 2-wire), reference temperature and so on.

Analog output (type 202731/01... only)

In this window, you can make settings concerning the analog output for conductivity, such as current/voltage output, scaling and so on.

Relay output (type 202731/02... only)

In this window, you can make settings concerning the relay output, such as min/max contact, switching point and so on.

Calibration timer

In this window, you will be able to specify calibration intervals, after which a calibration has to take place.

When the calibration timer has run down, the LED alternately switches between green and red.

Customized linearization for the temperature probe

This is used to adapt any temperature probe to the temperature input of the type 202731/01... or type 202731/02.

In the “Analog input for temperature” window, select “Customized probe type”.

Note

Because of the data format used, only the first and last interpolation points read back will correspond to the interpolation points transmitted. The intermediate values are calculated inside the device as equally spaced values.

Characteristics of sensor and medium

Parameters such as the relative cell constant and the temperature coefficient can be found here.

These data will only be displayed if they have been read out from the device or the appropriate saved file has been opened.

6.3.2 Operation through the teach-in connector

(type 202731/02... only)

In the learning (teach-in) mode, the switching point of the relay can be set using the teach-in connector (without the setup program).

Note

In the learning mode, the relay behaves as set in the setup program under “Response in calibration operation”.

The conductivity measured in the learning mode corresponds to the desired switching point.

The switching function has been defined so that the relay switches when the switching point (setpoint) has been exceeded. The hysteresis is set at 2% of the measuring range. A range with the correct cell constant must have been configured.

Procedure

- Type 202731/02... is operating (a conductivity sensor has been attached, the supply voltage has been connected).
- * Immerse the conductivity sensor into a solution with a known (desired) conductivity.
- * Plug the teach-in connector into the socket on type 202731/02.... The LED flashes green rapidly (4 times per second), green = the learning mode is active.
- The teach-in procedure lasts about 10 seconds.

Afterwards, the LED should flash green slowly (once per second) = OK, the learning mode has been successfully completed.

If the LED flashes red slowly (once per second)
= ERROR, the learning mode has **not** been successfully completed.

If the switching point has been found:

* Pull out the teach-in plug.

The device operates with the switching point that has been learned.

If the switching point has not been found:

* Pull out the teach-in plug.

The device operates with the original switching point.

Note

The learning mode can be activated by plugging the teach-in connector in again.

The learning mode can also be started without a connected conductivity sensor, whereby an ohmic resistance simulates the resistance of the liquid measured by the conductivity cell.

The required resistance can be determined as follows:

$$R = \frac{K}{L_f}$$

R = ohmic resistance [Ω]

K = cell constant of the actual conductivity sensor [1/cm]

L_f = conductivity at the desired switching point [S/cm]

Example

Type 202731/02... with the range

0 – 2 mS/cm; cell constant $K = 1.0 \text{ }^1/\text{cm}$

desired switching point $w = 0.8 \text{ mS/cm} = (0.0008 \text{ S/cm})$

$$R = \frac{1.0 \text{ }^1/\text{cm}}{0.0008 \text{ S/cm}} = 1250 \text{ } \Omega$$

The resistance that must be connected in place of the conductivity sensor has a value of 1250 Ω .

6.4 Calibration

General

The cell constants of conductivity sensors may vary somewhat depending on the type used, and additionally change during operation, for example, due to deposits such as lime, or as a result of wear. This results in a change in the output signal from the cell. It is therefore necessary for the user to be able to compensate for the deviations of the cell constant from the nominal value, either by manual entry or an automatic calibration of the cell constant K_{rel} .

The conductivity of a solution varies with temperature, so for correct measurement both the temperature and the temperature coefficient of the solution being measured must be known. The temperature can either be measured automatically, with a Pt100 or Pt1000 temperature probe or a customized temperature probe, or set manually by the user. The temperature coefficient can be determined automatically by the conductivity transmitter, or entered manually.

The time intervals between calibrations depend on the conditions in which the cell is used.

The device can draw your attention to a scheduled calibration by means of the calibration timer.

6.4.1 Characteristics of sensor and medium

The “Characteristics of sensor and medium” window is called up with the “screwdriver” icon.

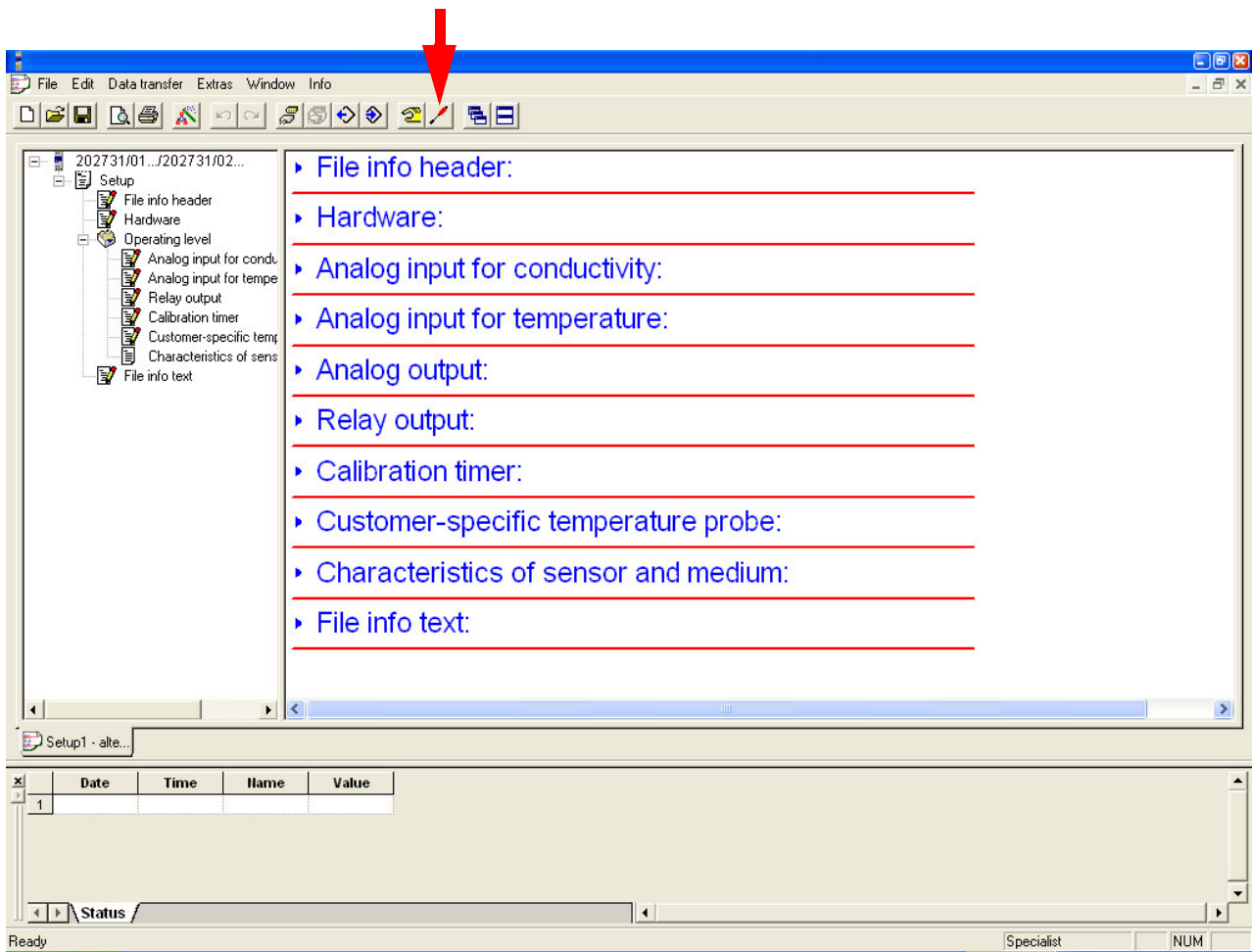

The data can be manually entered here or determined empirically and transferred to the device using an integrated routine.

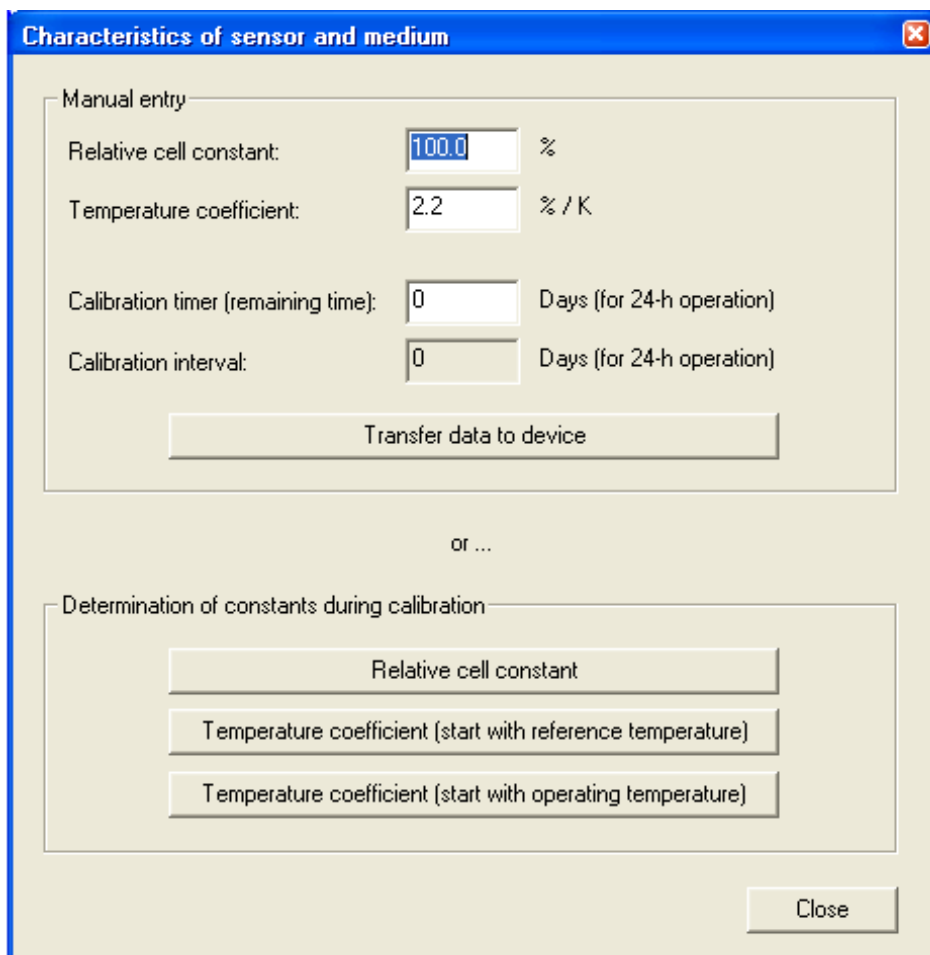

6.4.2 Preparing to calibrate the cell constant or the temperature coefficient

- * Connect the conductivity sensor to type 202731/01... or type 202731/02... .
- * Connect the type 202731/01... or type 202731/02... to the PC or laptop by means of the PC interface cable (Part no. 00456352).

Caution

The PC or notebook must not be electrically connected to ground or connected to a network, see page 13.

- * Apply supply voltage.
- * Start the setup program.

6.4.3 Calibrating the cell constant

The sequence is defined by the setup program.

- * Immerse the conductivity sensor into a solution with a known conductivity.
- * In the setup program, start “Calibration of the cell constant” by activating the “Relative cell constant” button.
- * Accept the calculated cell constant with “Yes” or discard it with “No”.

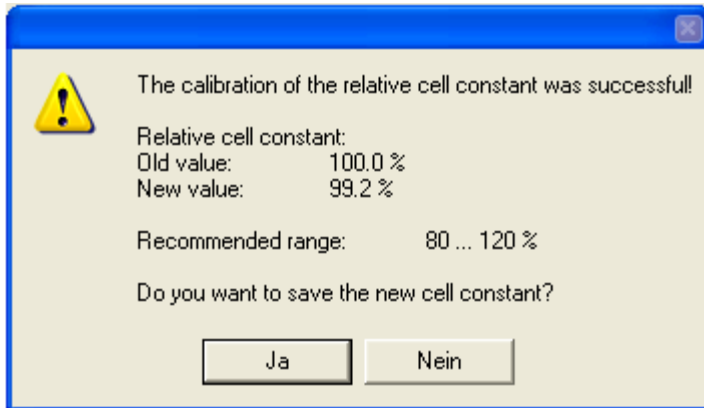

Note

If the calibration of the cell constant has been concluded with “Yes”, the calibration timer is reset and restarted.

6.4.4 Calibrating the temperature coefficient

Calibration of the temperature coefficient takes place at two temperatures (temperature 1 = reference temperature and temperature 2 = working temperature).

The uncompensated conductivities that were determined at these temperatures are used to specify the linear temperature coefficient.

The sequence is defined by the setup program.

- * Immerse the conductivity cell and the temperature probe (if available) into the solution.
- * In the setup program, start “Calibration of the temperature coefficient” by activating the “Temperature coefficient” button (start at the reference temperature or start at the operating temperature).

* The calculated value will be displayed at the end of the routine.

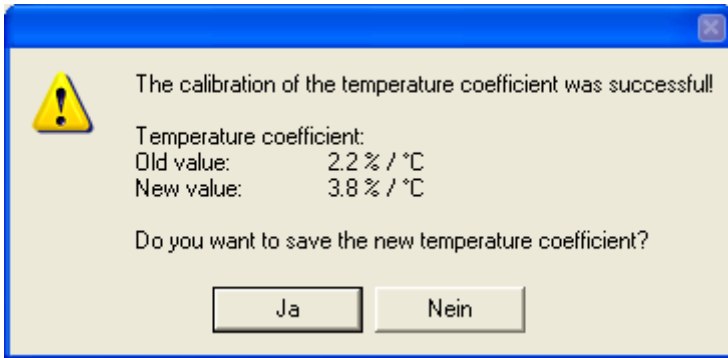

Notes

The temperature coefficient of the measurement solution must not exceed 5.5 %/K.

Wait until the temperature measurement is stable, i.e. observe the t_{90} time of the temperature probe. A waiting time of about 5 minutes has proved to be useful in practice.

If the calibration of the temperature coefficient has been concluded with "Yes", the calibration timer is reset and restarted.

6.5 Manual entry of temperature coefficient and cell constant

The values can be entered in the "Characteristics of sensor and medium" dialog of the setup program, see page 19.

Characteristics of sensor and medium

Manual entry

Relative cell constant: %

Temperature coefficient: % / K

Calibration timer (remaining time): Days (for 24-h operation)

Calibration interval: Days (for 24-h operation)

or ...

Determination of constants during calibration

6.6 Manual mode

This function can be used to manually control the analog output or relay.

Note

On leaving the manual mode, the outputs behave in accordance with the defined parameters.

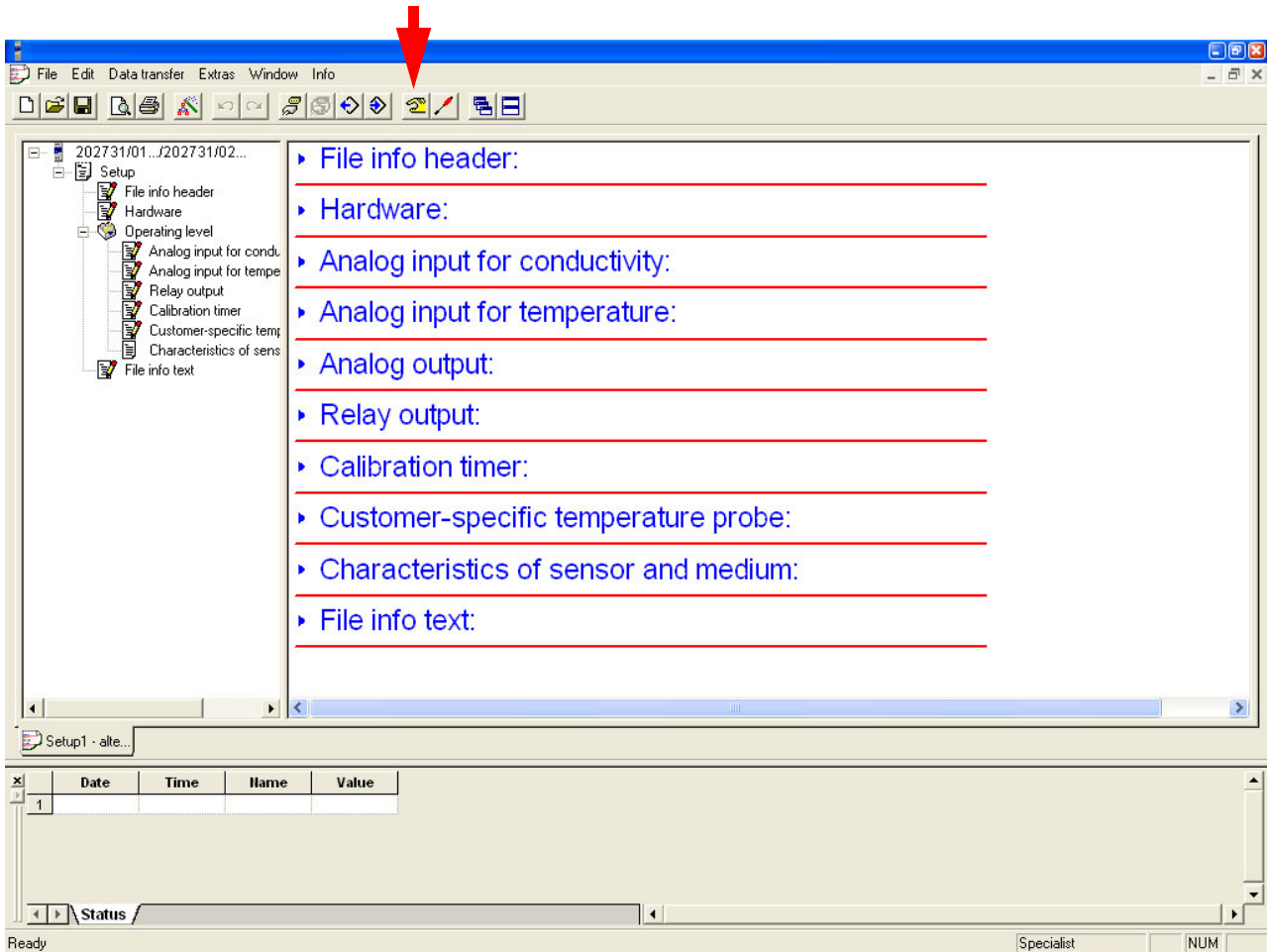

6.7 Analog output (type 202731/01...)

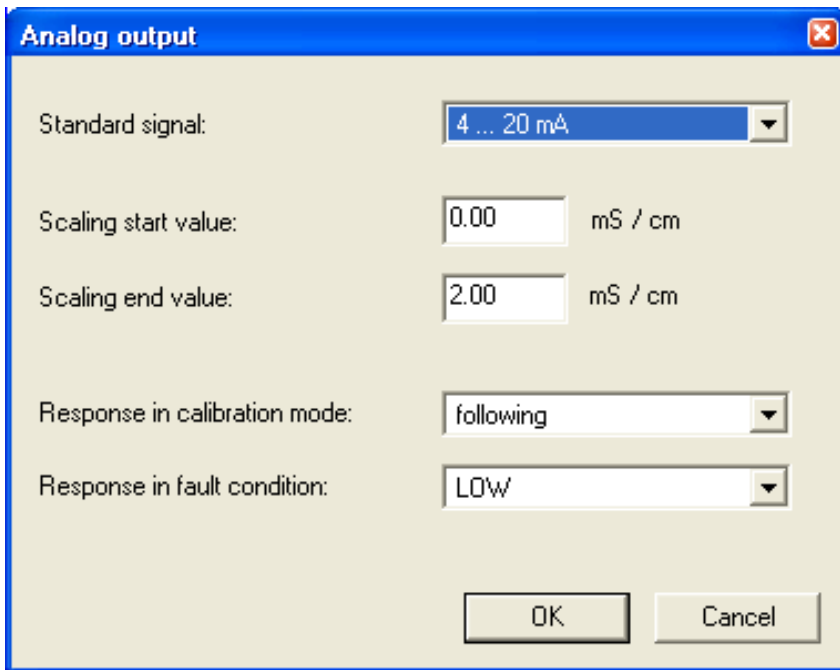

Response after switching on the supply voltage

During switch-on (about 2 sec), the output signal is 0 V or 0 mA.

Response during calibration

You can choose between “following” or “unchanged” (constant).

Response of the output signal in fault condition

Depending on the type of error, the output signal can adopt the “LOW” or “HIGH” condition.

Output signal nominal	Output signal HIGH	Output signal LOW
0 – 20 mA	22.0 mA	0 mA
4 – 20 mA	22.0 mA	3.4 mA
0 – 10 V	10.7 V	0 V
2 – 10 V	10.7 V	1.4 V

Response of the output signal on leaving the scaling range

As per NAMUR NE43 recommendation, the output signal of the typ 202731/01... adopts the following defined values on going above or below the scaling range:

below scaling range	within scaling range	above scaling range
0.0 mA	0 – 20 mA	20.5 mA
3.8 mA	4 – 20 mA	20.5 mA
0.0 V	0 – 10 V	10.2 V
20.5 mA	20 – 0 mA	0.0 mA
20.5 mA	20 – 4 mA	3.8 mA
10.2 V	10 – 0 V	0.0 V
1.8 V	2 – 10 V	10.2 V
10.2 V	10 – 2 V	1.8 V

Manual operation of the analog output

The analog output can be manually controlled in the setup program, see Chapter 6.6 „Manual mode“, page 24.

6.8 Relay output (type 202731/02...)

Relay output

Switching function (LK): MAX contact

Switching point: 2.00 mS / cm

Hysteresis: 0.04 mS / cm

Pull-in delay: 2 s

Drop-out delay: 1 s

Pulse time: 0 s

Response in calibration mode: Relay inactive

Response in fault condition: Relay inactive

OK Cancel

Response after switching on the supply voltage

During switch-on (about 2 sec), the relay is in the de-energized condition (inactive).

Response of the relay

Depending on the setting (through the setup program), the typ 202731/02... monitors a limit, similar to a limit comparator (LK), as a MAX or MIN LK.

The hysteresis (differential) is asymmetric with respect to the limit.

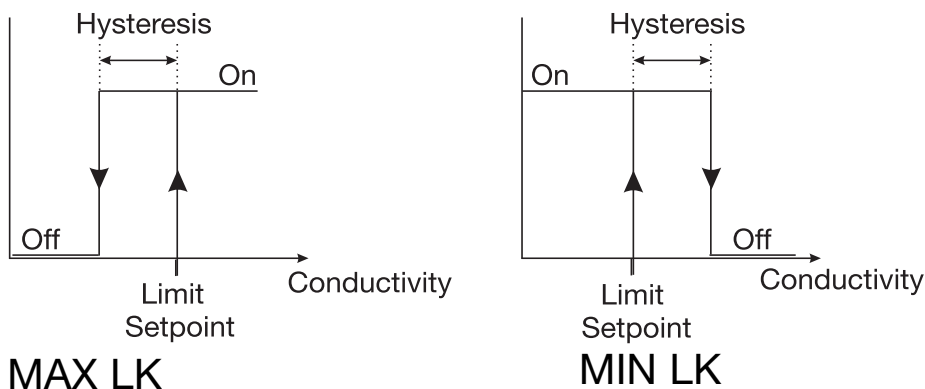

Manual operation of the relay

The relay can be manually set to “active” or “inactive” in the setup program. When leaving the manual mode, the switching condition of the relay will depend on the conductivity and the limit, see Chapter 6.6 „Manual mode“, page 24.

Response of the relay during calibration and in fault condition

The setup program can be used to set the relay response to

- relay unchanged
(during calibration, the relay status remains at the status that was valid before the start of the calibration) or
- relay active or
- relay inactive.

Pulse function of the relay output

The limit comparator is reset after a “pulse time” that can be set in the setup program.

The LED is red as long as the switching condition is fulfilled.

The pulse function is used for collective alarm messages, for example.

Caution

Switch-on or switch-off delay is not possible in pulsed operation.

6.9 LED messages

The LED indicates the device status

LED	Device status
green light is on	power ON relay is inactive (type 202731/02...)
green light flashes once per second	switching point found (type 202731/02...)
green light flashes 4 times per second	learning (teach-in) mode is activated (type 202731/02...)
red light is on	relay is active (type 202731/02...)
red light flashes once per second	ALARM Cause: <ul style="list-style-type: none">• probe break or short-circuit of temperature probe or• infringement of temperature range (over/underrange) or• infringement of conductivity range (over-range)• teach-in operation: switching point not found
green/red light flash alternately	calibration timer has run down: the type 202731/01... or type 202731/02... is due for recalibration (cell constant and/or temperature coefficient)

7 Technical data

Analog input 1 (conductivity)

Electrolytic conductivity sensors with the cell constants 0.01; 0.1; 1.0; 10.0 $1/\text{cm}$ (2-electrode principle).

The cell constant can be adjusted over the range 20 – 500 %.

Lead compensation, analog input 1

The effect of long cables can be compensated on ranges above about 20 mS/cm by entering the resistance of the incoming cable, within the range 0.00 to 99.99 Ω .

Zero-point calibration, analog input 1

Zero-point errors caused by the system can be compensated.

Analog input 2 (temperature)

- Pt100 or Pt1000 resistance thermometer, in 2-wire or 3-wire circuit
- NTC or PTC using customized characteristic (see page 19)
- measuring range: -10 to +250 °C
- maximum resistance: 4500 Ω

Using the setup program, an actual-value correction can be carried out within the range -20 to +20 °C.

Measuring and control range

0 – 5 μS to 0 – 200 mS, depending on the cell constant.

Cell constant K	Measuring range
0.01 $1/\text{cm}$	0 – 5 $\mu\text{S}/\text{cm}$
	0 – 20 $\mu\text{S}/\text{cm}$
0.1 $1/\text{cm}$	0 – 200 $\mu\text{S}/\text{cm}$
	0 – 1000 $\mu\text{S}/\text{cm}$
1 $1/\text{cm}$	0 – 2 mS/cm
	0 – 20 mS/cm
10 $1/\text{cm}$	0 – 100 mS/cm
	0 – 200 mS/cm

Deviation from characteristic, conductivity

on ranges 0 — 5 $\mu\text{S}/\text{cm}$

≤ 1.0 % of range

on ranges 0 — 20 $\mu\text{S}/\text{cm}$

≤ 1.0 % of range

All other ranges:

≤ 2.0 % of range

Reference temperature (for temperature compensation)

settable from 10 to 40 $^{\circ}\text{C}$ (factory setting: 25 $^{\circ}\text{C}$)

Temperature range

-10 to +250 $^{\circ}\text{C}$

Deviation from characteristic, temperature

with Pt100 and Pt1000:

≤ 0.6 % of range

with customized characteristic

≤ 5 Ω

Outputs

Type 202731/01... (analog output)

freely configurable:

0(2) — 10 $\text{V}R_{\text{load}} \geq 2$ $\text{k}\Omega$ or

10 — 0(2) $\text{V}R_{\text{load}} \geq 2$ $\text{k}\Omega$ or

0(4) — 20 $\text{mA}R_{\text{load}} \leq 400$ Ω or

20 — 0(4) $\text{mA}R_{\text{load}} \leq 400$ Ω

electrically isolated from the inputs:

$\Delta U \leq 30$ V AC or

$\Delta U \leq 50$ V DC

Deviation of the output signal

± 0.015 mA or ± 5 mV ± 50 ppm/K

Typ 202731/02... (relay output)

changeover contact

contact rating:4 A, 250 V AC, with resistive load

4 A, 24 V DC, with resistive load

current rating:4 A

contact life:> 100,000 operations at rated load

7.1 General characteristics

A/D converter

resolution 14 bit

Sampling time

500 msec = 2 measurements per second

Ambient temperature drift

≤ 0.5 %/10 °C

Measuring circuit monitoring

input 1 (conductivity):

out-of-range

input 2 (temperature):

out-of-range, probe short-circuit, probe break

In fault condition, the outputs adopt a defined (configurable) state.

Data backup

EEPROM

Supply voltage

20 – 30 V DC, ripple < 5 %

power consumption ≤ 2 W,

with reverse-polarity protection

To be used only on SELV or PELV electrical circuits.

Electrical connection

screw terminals up to 2.5 mm²

Permissible ambient temperature

-10 to +60 °C

Permissible storage temperature

-20 to +75 °C

Climatic conditions

rel. humidity ≤ 93 %, no condensation

Enclosure protection (to EN 60529)

IP20

Electrical safety

to EN 61010

clearance and creepage distances for

- overvoltage category II
- pollution degree 2

Electromagnetic compatibility

to EN 61326

interference emission: Class B

interference immunity: to industrial requirements

Housing

housing for DIN rail mounting: PC (polycarbonate)

Mounting

on 35 mm × 7.5 mm DIN rail to EN 60715

Operating position

unrestricted

Weight

approx. 110 g

8 Environment/waste disposal

Faulty devices can be returned to the manufacturer for proper disposal.

9 China RoHS

	 					
产品组别 Product group: 202731	产品中有害物质的名称及含量 China EEP Hazardous Substances Information					
部件名称 Component Name						
	铅 (Pb)	汞 (Hg)	镉 (Cd)	六价铬 (Cr(VI))	多溴联苯 (PBB)	多溴二苯醚 (PBDE)
外壳 Housing (Gehäuse)	○	○	○	○	○	○
过程连接 Process connection (Prozessanschluss)	○	○	○	○	○	○
螺母 Nuts (Mutter)	○	○	○	○	○	○
螺栓 Screw (Schraube)	○	○	○	○	○	○
<p>本表格依据SJ/T 11364的规定编制。 This table is prepared in accordance with the provisions SJ/T 11364. ○ : 表示该有害物质在该部件所有均质材料中的含量均在GB/T 26572规定的限量要求以下。 Indicate the hazardous substances in all homogeneous materials' for the part is below the limit of the GB/T 26572.</p> <p>× : 表示该有害物质至少在该部件的某一均质材料中的含量超出GB/T 26572规定的限量要求。 Indicate the hazardous substances in at least one homogeneous materials' of the part is exceeded the limit of the GB/T 26572.</p>						



JUMO GmbH & Co. KG

Street address:
Moritz-Juchheim-Straße 1
36039 Fulda, Germany
Delivery address:
Mackenrodtstraße 14
36039 Fulda, Germany
Postal address:
36035 Fulda, Germany
Phone: +49 661 6003-0
Fax: +49 661 6003-607
Email: mail@jumo.net
Internet: www.jumo.net

JUMO Instrument Co. Ltd.

JUMO House
Temple Bank, Riverway
Harlow, Essex, CM20 2DY, UK
Phone: +44 1279 63 55 33
Fax: +44 1279 62 50 29
Email: sales@jumo.co.uk
Internet: www.jumo.co.uk

JUMO Process Control, Inc.

6733 Myers Road
East Syracuse, NY 13057, USA
Phone: +1 315 437 5866
Fax: +1 315 437 5860
Email: info.us@jumo.net
Internet: www.jumousa.com

