

# SR1, SR3 Series Digital Controller Instruction Manual

Please do not begin operating this product until you have read this instruction manual thoroughly and you understand its contents.

## Safety Rules

For matters regarding safety, potential damage to equipment and/or facilities, additional instructions and notes are indicated by the following headings.

### ⚠ WARNING

This heading indicates hazardous conditions that could cause injury or death of personnel unless extreme caution is exercised.

### ⚠ CAUTION

This heading indicates hazardous conditions that could cause damage to equipment and/or facilities unless extreme caution is exercised.

### NOTE

This heading indicates additional instructions and/or notes.

### ⚠ WARNING

The SR1, SR3 series digital controller is designed for controlling temperature/humidity and other physical quantities of general industrial equipment.

Avoid using it for control of devices upon which human life is dependant. When used, adequate and effective safety measures must be taken.

No warranty is valid in the case of an accident arising from the use of this product without having taken such safety measures.

### ⚠ CAUTION

- To avoid damage to connected equipment, facilities or the SR1, 3 itself due to a fault of the product, safety measures must be taken before usage, such as the installation of a fuse, an overheating protection device and the like.
- As a means to turn the power off, a switch or a breaker (which confirms with IEC 60947) should be installed in the external power circuit to be connected to the power terminal of the instrument.
- Since the instrument does not have a built-in fuse, do not forget to install a fuse in the power circuit to be connected to the power terminal.  
Fuse rating/characteristics: 250V AC 0.5A/medium lagged or lagged type.  
Use a fuse which conforms with IEC 60127.

### ⚠ CAUTION

- Do not use this instrument other than specified.
- Using the instrument other than specified may result in trouble with the instrument or may cause a fire.
- Voltage/current of a load to be connected to the output terminal should be within a rated range.
- Do not block the draft hole or allow dust and the like to stick to the case of the instrument for heat discharge.  
A rise in temperature or insulation failure may result in a reduction of the life of the product and/or problems with it or may cause a fire.
- Do not operate keys on the front panel with a hard or sharply pointed object. Operate the keys only by softly touching them by your finger tips.
- When cleaning the instrument, wipe it gently with a dry cloth. Never use solvent such as thinner.

## 1. Introduction

### 1-1. Check before Use and Confirmation of Model Codes

This product has been fully inspected for quality assurance prior to shipment. However, you are requested to make sure that there is no error, damage or shortage of delivered items by checking the model codes and the external view of the product.

#### Confirmation of Model Codes

Check the model codes affixed to the case of the product to ascertain if the respective codes designate what was specified when you ordered it, referring to the following code table.

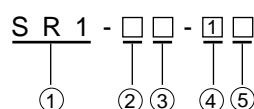

- |                  |  |
|------------------|--|
| ① Series code    | <b>SR1:</b> 48×48mm DIN<br><b>SR3:</b> 96×96mm DIN   |
| ② Input          | [8] Thermocouple, R.T.D., mV Voltage, Multi-input<br>[6] Voltage: -1~1, 0~1, 0~2, 0~5, 1~5, 0~10V DC<br>* Will correspond to external mounting resistance of (250Ω) for current input. |
| ③ Control output | [Y] Contact, [I] Current, [P] SSR drive voltage, [V] Voltage   |
| ④ Event          | [1] 1×2  |
| ⑤ Remarks        | [0] Without, [9] With  |

## 2. About Installation

### 2-1. Installation

This instrument is created with the premise of being used by setting on the instrumentation panel. Therefore, please make sure that the user would not come in contact with the live part of the power terminals and the like.

### 2-2. Installation Conditions (environmental conditions)

#### Note:

This instrument should not be used in any of the places mentioned below. Selection of any of the places may result in trouble with the instrument, damage to it or even a fire.

- ① Where flammable gas, corrosive gas, oil mist and particles that can deteriorate electrical insulation are generated or abundant.
- ② Where the temperature is below -10°C or above 50°C.
- ③ Where the relative humidity is above 90% RH or below the dew point.
- ④ Where highly intense vibration or impact is generated or transferred.
- ⑤ Where the instrument is exposed to dew drops or direct sunlight.
- ⑥ Where the instrument is directly exposed to the air of the heater or the air conditioner.
- ⑦ Where the height is above 2000m.

### 2-3. Site selection

This instrument is specified to be used in the following environment conditions.

- ① Over voltage category II
- ② Degree of pollution 2 (IEC60664)/(IEC 61010-1)
- ③ Where the height is below 2000m

### 2-4. Mounting

- ① Cut a hole for mounting the controller in the panel by referring to the cutout drawing in section 2-5.
- ② The panel thickness should be 1.0~4.0mm.
- ③ As the instrument is provided with pawls for fixing, just press it firmly from the front of the panel.
- ④ Please mount vertically in order to satisfy the dust-proof/drip-proof (NEMA4X, IP66) specification.

### 2-5. External Dimensions and Panel Cutout

#### SR1 (48×48mm size)

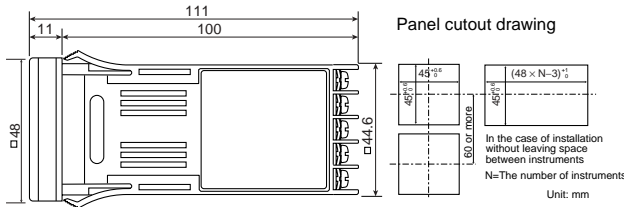

**Note:** When installing without leaving space between instruments, dust-proof/drip-proof, (NEMA4X, IP66) specification would not be satisfied.

#### SR 3 (96×96mm size)

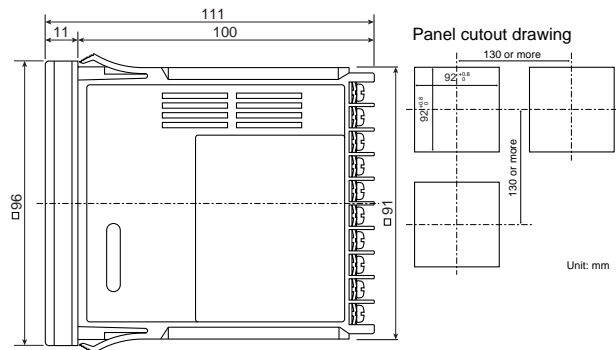

**Note:** Extracting the internal portion of the instrument For safety's sake and to protect the functionality of the product, do not draw out the body from its case. IEC 61010-1 safety standards request for the use of tools when extracting the internal portion of this instrument from the case. This is designed to prevent electric shock. Recommended tools (minus driver, shape of the tip: width 4.5mm, thickness 0.5mm)

## 3. Wiring

### ⚠ WARNING

- Make sure to disconnect this product from any power source during the wiring operation. Otherwise an electric shock may result.
- To prevent an electric shock, do not touch wired terminals and other charged elements while they are being energized.

### 3-1. Note on Wiring

- ① In the wiring operation, follow the terminal layout shown in section 3-2 and make sure to carry out the correct wiring process.
- ② Use a press fit terminal which fits an M3.5 screw and has a width of 7mm or less.
- ③ In case of thermocouple input, use a compensating wire compatible with the selected type of thermocouple.
- ④ In case of R.T.D. input, the resistance of a single lead wire must be 5Ω or less and the three wires must have the same resistance.
- ⑤ When the current input is 0~20mA (0~5V DC), 4~20mA (1~5V DC), select input [6] (see 1-22) and apply supplied shunt resistor of 250Ω ±0.1% between the input terminals + and - for the use of instrument.
- ⑥ The input signal wire must not be accommodated with a high voltage power cable in the same conduit or duct.
- ⑦ Shield wiring (single point grounding) is effective against static induction noise.
- ⑧ Twisting the input wires at short and equal intervals is effective against electromagnetic induction noise.
- ⑨ Clamp the screws of terminals firmly. Clamping torque: 1.0 N · m (10 kgf · cm)
- ⑩ If the instrument appears to be easily affected by power supply noise, use a noise filter to prevent malfunctioning. Mount the noise filter on the grounded panel and make the wire connection between the noise filter output and the power line terminals of the controller as short as possible.

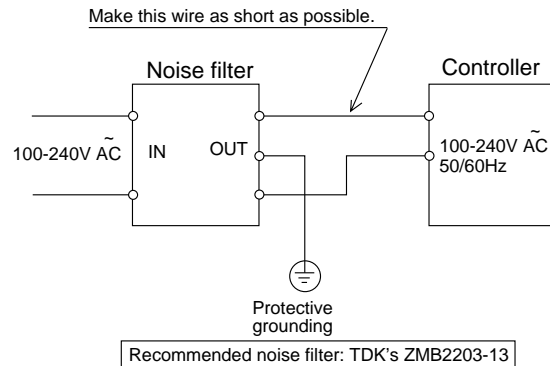

### 3-2. Terminal Layout

#### SR1

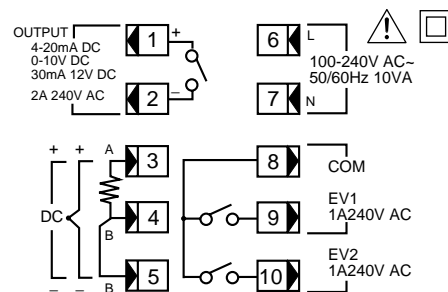

### SR3

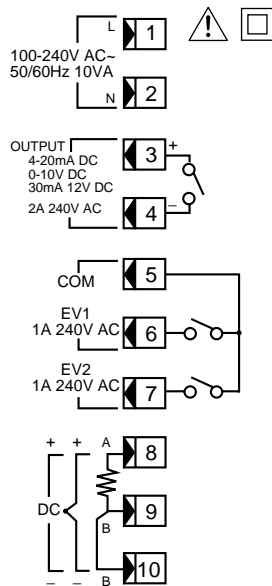

3-3. Terminal Arrangement Table

Name of terminal		Terminal No.	
		SR1	SR3
Power terminal	100-240V AC-10% 50/60Hz 10VA	6-7	1-2
Input signal	R.T.D.: A, thermocouple/voltage: +	3	8
	R.T.D.: B	4	9
	R.T.D.: B, thermocouple/voltage: -	5	10
Output terminal	Contact: COM, SSR drive voltage/voltage/current: +	1	3
	Contact: NO, SSR drive voltage/voltage/current: -	2	4
Event output terminal	COM: Common terminal	8	5
	EV1: Event 1 output terminal (standard)	9	6
	EV2: Event 2 output terminal (standard)	10	7

**Note:** Shorting across B and B terminal will cause an error when thermocouple/voltage/current is inputted. If used with input current, apply supplied shunt resistor of 250Ω ±0.1% between input terminals (+, -).

### 4. Outline of Specifications

Display	
Display accuracy	± (0.5% FS+1 digit)
Display accuracy maintaining range	23±5°C
Measured value display range	Input range or -10~110% of measuring range
Setting	
Setting method	By operating 4 keys on the front panel
Setting limiter	Within the measuring range, individual setting for higher and lower limits (Lower limit<Higher limit)
Input	
Input type	Multi input (TC, Pt100, Jpt100, mV) V (In case of mA input, connect receipt resistance between the input terminals)
PV bias	-1999~2000 Unit
PV filter	0~100 seconds
Control	
Control mode	Auto tuning PID control, manual control
Type of control output	Relay contact, SSR drive voltage, voltage, current
Output control characteristics	RA/DA switching
Output limiter	Lower limit: 0.0~99.9% Upper limit: lower limit +0.1~100.0%

### Event

Output points	2 points EV1, EV2
Contact rating	240V AC 1A (resistive load)
Event type	Absolute values, deviations (higher, lower, higher/lower, within, outside)
Event action	On-Off action
Standby action	Selectable from the 3-type standby mode

### General specifications

Ambient temperature for operational condition	-10°C~+50°C
Supply voltage	100~240V AC±10% 50/60Hz
Power consumption	Approximately 10VA

### 5. Names and Functions of Parts on Front Panel

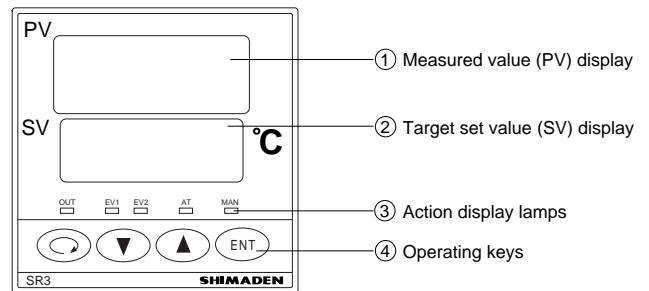

Name	Function
① Measured value display	<ul style="list-style-type: none"> <li>Displays measured value (PV) or each type of parameter signs (red)</li> </ul>
② Target set value display	<ul style="list-style-type: none"> <li>Displays target set value (SV), each type of parameter set value</li> <li>Output value is displayed by % on control output monitor screens of the screen group 0 (green)</li> </ul>
③ Action display	<ul style="list-style-type: none"> <li>Out (green) /Control output display</li> <li>Lights when output turns on during contact or SSR drive voltage output.</li> <li>Turns off when output is 0% during voltage or current and flashes continuously when output is 100%.</li> <li>Flashes on a equal basis of 0.5 sec for others.</li> <li>EV1, EV2 (orange) / Event output display</li> <li>Lights during event output.</li> <li>AT (green) / auto tuning action display</li> <li>Flashes when ON key is selected by (▲) key on the AT action selection screen and AT is executed by (ENT) key and goes out when AT terminates automatically or is released.</li> <li>MAN (green) /Manual control action display</li> <li>Flashes when manual control action mode is selected.</li> </ul>
④ Operating keys	<ul style="list-style-type: none"> <li>(○) Parameter key</li> <li>Pressing this key on any screen of the screen group 0 and the screen group 1 calls the next screen onto display.</li> <li>When pressed continuously for 3 seconds, this key functions to move toward the basic screen of screen group 0 and the initial screen of screen group 1.</li> <li>(▼) Down key</li> <li>When pressed on each of the screen, the decimal point of the rightmost digit flashes and the set data decreases or moves backward.</li> <li>(▲) Up key</li> <li>When pressed on each of the screen, the decimal point of the rightmost digit flashes and the set data increases or moves forward.</li> <li>(ENT) Registration (entry) key</li> <li>Used to register a set data changed by means of (▲) or (▼) key on a parameter screen. (The flashing right most digit turns off.)</li> <li>When pressed continuously for 3 seconds on the control output screens (mode 0 to 1), this key functions to switch between the manual control mode (Man flashes) and the automatic control mode (Man turns off).</li> </ul>

## 6. Explanation of Screens and Setting

### 6-1. How to change screens

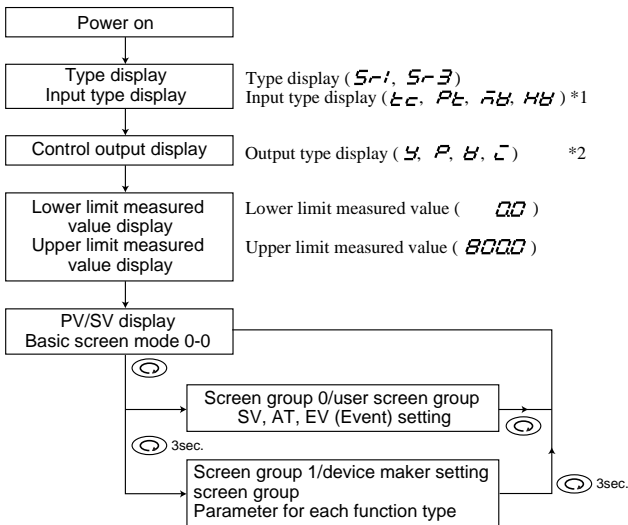

Pressing the key continuously for 3seconds calls the 1-0 initial screen of screen group 1.

- \*1: Input type display  
*tc*: Thermocouple, *Pt*: R.T.D, *mV*: Voltage (mV),  
*HV*: Voltage (V)  
 \*2: Output type display  
*Y*: Contact, *P*: SSR drive voltage, *B*: Voltage, *C*: Current

### 6-2. Mode 0 screen group

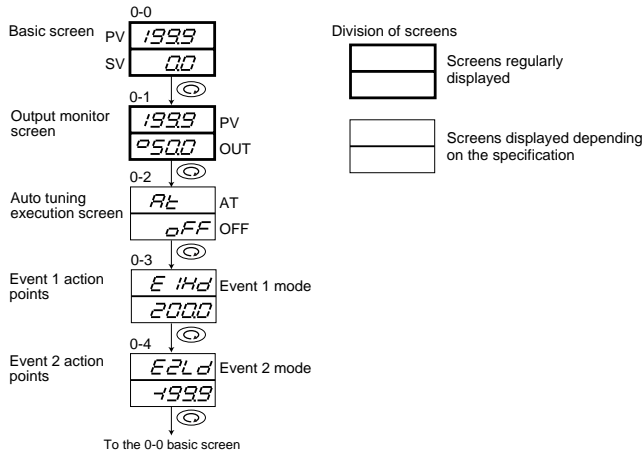

### 6-4. Mode 1 (Device maker setting screen group)

Pressing the key continuously for 3 seconds on the basic screen will proceed to the mode 1 screen group.

Mode No. Screen title	Setting range ( ) = initial value	Function
1-0 Initial screen		Initial screen
1-1 Key lock setting	OFF 1~3 (OFF)	OFF: Key control possible for all screens 1: Key control not possible for screens except user setting screen group 2: Key control not possible for other than SV setting 3: All key control not possible
1-2 Proportional band setting	OFF, 0.1~999.9% (3.0) Control output: During contact P=OFF (factory setting)	The width of proportional band will be set during the time of control. The smaller the proportional band, the larger the output difference for the deviation (gap between PV and SV).

\*When the key is pressed while the key is being pressed, the preceding setting screen is called back.

### (1) Manual control of control output (manual mode)

#### 0-1 (Output monitor screen)

To Switch Automatic→Manual, Manual→Automatic, press the key for 3 seconds continuously on the 0-1 screen. Upon turning to manual, the MAN lamp flashes and the output value can be selected by the use of and keys. To cancel, press the key again for 3 seconds continuously and automatic output will return.

### (2) Auto tuning (Initial value: OFF)

#### 0-2 (Auto tuning execution screen will not be displayed when P=OFF is set.)

AT is a function of automatically processing and setting P.I.D. control.

Pressing the and keys changes *OFF* to *ON* and the decimal point of the rightmost digit flashes. When key is pressed the decimal point stops flashing and the AT display lamp will flash and start auto tuning. When AT finishes, the flashing will turn off. Auto tuning will calculate the PID value and will store data by the ON-OFF action in Target Set Value (SV). To stop AT in the middle of execution, select *OFF* and press the key to release.

### (3) Event 1 action point setting (Initial value: refer to the below table)

When the and keys are pressed on the setting screen, the decimal point of the rightmost digit flashes and the numerical value can be changed. The set numerical value will be registered and the digit will go off when the key is pressed.

### (4) Event 2 action point setting (Initial value: refer to the below table)

When the and keys are pressed on the setting screen, the action point can be set and the rest is the same as above in Event 1.

### 6-3. Setting the Event Action Point

Alarm code	Action	Initial value	Setting range
<i>OFF</i>	None		
<i>Hd</i> (1)	Higher limit deviation value	2000	-1999~2000 Unit
<i>Ld</i> (2)	Lower limit deviation value	-1999	-1999~2000 Unit
<i>Od</i> (3)	Outside Higher/Lower limit deviation	2000	0~2000 Unit
<i>Id</i> (4)	Inside Higher/Lower limit deviation	2000	0~2000 Unit
<i>HR</i> (5)	Higher limit absolute value	Higher limit value measuring range, within measuring range	
<i>LR</i> (6)	Lower limit absolute value	Lower limit value measuring range, within measuring range	
<i>So</i> (7)	Scale over		

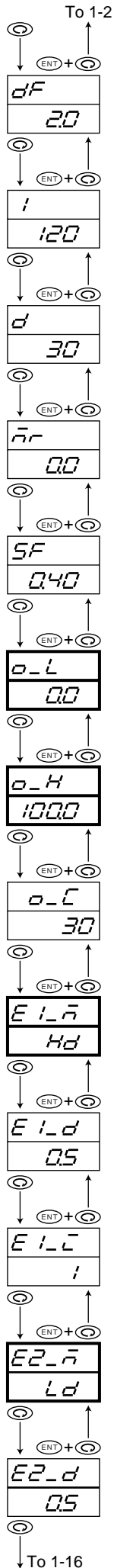

Mode No. Screen title	Setting range ( ) = initial value	Function
1-3 Hysteresis setting	1~999 Unit (20)	The width of hysteresis during ON-OFF control P=OFF Displays while setting.
1-4 Integral time setting	OFF, 1~6000 sec. (120) P or P+D control when OFF setting	Time setting to cancel the offset (deviation) which occurs during proportional control Integral action cannot take action when I=OFF. No display when P=OFF.
1-5 Derivative time setting	OFF, 1~3600 sec. (30) P or P+I control when OFF setting	Estimates the fluctuation of the outcome of control and will conduct correction. Integral action cannot take action when d=OFF. No display when P=OFF.
1-6 Manual reset setting When I:OFF is set	-50.0~50.0% (0.0)	Will correct the offset which occurred at proportional control manually. No display when P=OFF.
1-7 Target value function setting	OFF, 0.01~1.00 (0.40)	A function which controls the overshoot and undershoot when the target value is reached. The effect is large when 1.00 and small when 0.00. No display when P=OFF.
1-8 lower limit output limiter setting	0.0~99.9% (0.0)	Will set the control output of lower limit value.
1-9 higher limit output limiter setting	0~L+0.1~100.0% (100.0)	Will set the control output of higher limit value.
1-10 Proportional cycle time setting When Y, P is output	1~120 sec (Y: 30, P: 3) No display when I, V is output	The output of the proportional cycle will be set when contact and SSR drive voltage are outputted. No display if the type of the control output is current or voltage.
1-11 EV1 type Code setting	OFF, Hd~So (HD)	<i>oFF</i> : None <i>Hd</i> : Higher limit deviation <i>Ld</i> : Lower limit deviation <i>od</i> : Outside higher/lower limit deviations <i>cd</i> : Within higher/lower limit deviations <i>HA</i> : Higher limit absolute value <i>LA</i> : Lower limit absolute value <i>So</i> : Scale over
1-12 EV 1 Hysteresis setting	1~999 Unit (5) Alarm code No display when So (So: scale over, see 6-3)	The width of hysteresis when alarm relay is ON and OFF.
1-13 EV 1 Standby action setting	1~4 (1) Alarm code No display when So	1: No standby action 2: Standby action only when power is applied 3: Standby action when power is applied or when changed to SV 4: Control mode (no standby)
1-14 EV 2 type Code setting	OFF, Hd~So (LD)	Same as EV1
1-15 EV 2 Hysteresis setting	1~999 Unit (5) Alarm code No display when So	Same as EV1

\*When the key is pressed while the key is being pressed, the preceding setting screen is called back.

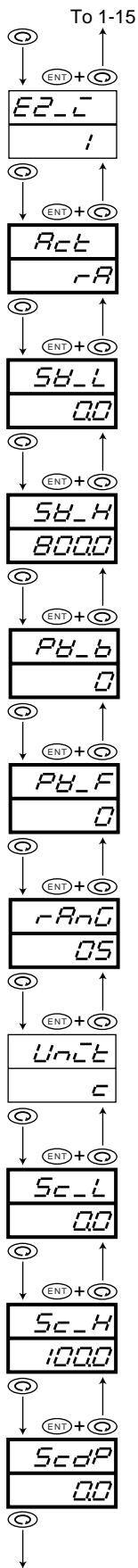

Mode No. Screen title	Setting range ( ) = initial value	Function
1-16 EV 2 Standby action setting	1~4 (1) Alarm code No display when So	Same as EV1
1-17 Control output characteristics setting	rA/dA (rA)	Switching the characteristics of control action rA : heating/humidify (reverse action) dA : cooling/dehumidify (direct action)
1-18 SV lower limiter setting	Lower limit value of measuring range (0.0)  within measuring range SV_L<SV_H	In case a narrower setting range of target value than a measuring range is used, a lower limit value is set.
1-19 SV higher limiter setting	Higher limit value of measuring range (800.0)	In case a narrower setting range of target value than a measuring range is used, a higher limit value is set. (It can prevent erroneous setting in a risky range and has some other advantageous effect.)
1-20 PV bias value Setting Screen	-1999~2000 Unit (0/0.0)	This value is used to correct an input error from a sensor or the like. The displayed value will change based on the set number. When a bias is given, control is also carried out with a corrected value.
1-21 PV Filter time setting screen	0~100 sec (0)	Incase input changes conspicuously or noise continues, PV filter is used to mitigate such undesirable effect. When 0 second is set, filter does not function.
1-22 Measuring range code setting screen	Multi: 01~76 (05) HV: 81~86 (86) ((05), (86): Default value)	Each code represents a combination of an input type and a measuring range. (Refer to 9. Table of Measuring Range Codes)
1-23 Input unit setting screen	C/F (°C)	Select the temperature unit for sensor input and register by ENT key. This screen is not displayed when linear input (mV, V or mA) is set.
1-24 Input scaling Lower limit value setting	-1999~9999 unit (0.0)	A lower limit value of scaling of linear input is set and registered by ENT key. (For sensor input, the screen is for monitoring only and setting is not possible.)
1-25 Input scaling Higher limit value setting	SCL+10~SCL+5000 (100.0)	A higher limit value of scaling of linear input is set and registered by ENT key. (For sensor input, the screen is for monitoring only and setting is not possible.)
1-26 Input scaling Decimal point setting	None~0.001digit on the right of decimal point (0.0)	The position of decimal point during linear input scaling is set and is registered by ENT key. (For sensor input, the screen is for monitoring only and setting is not possible.)

\*Sensor Input: Thermocouple, R.T.D. input  
Linear Input: Voltage (mV, V) input



## 7. Event Action

### 7-1. Deviation Alarm

The alarm action point will change along with the Target set value (SV). For example, when the target set value is 20°C, +10 should be set for higher limit deviation alarm in order to put an alarm in action at 30°C and higher. To put an alarm action at 30°C and lower when the target set value is 100°C, -70°C should be set for higher limit deviation alarm.

### 7-2. Absolute Value Alarm

An alarm action point is set by an absolute value. For example, when the measured value exceeds 100°C, 100°C should be set for higher limit absolute alarm in order to put an alarm in action at 100°C and higher. To put an alarm in action at 70°C and lower 70°C should be set for lower limit absolute alarm.

In case of absolute value alarm, the alarm only works for the measured value (PV) with no relation to the target set value (SV).

### 7-3. Standby Action (Mode 1-13)

This is used to withhold alarm action even when an alarm action point is reached when power is applied and to put the alarm in action on the alarm action point after a target set value (SV) is reached.

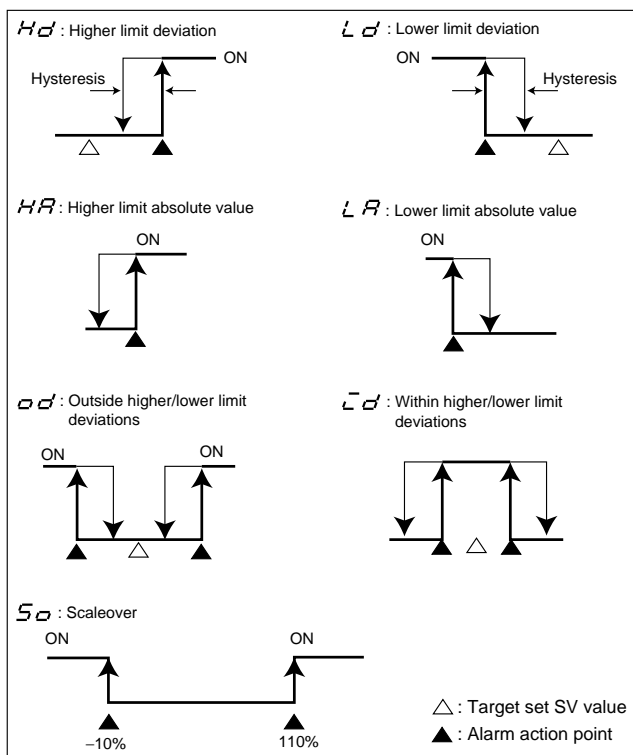

[Event action figure]

- ① Select an action code from the standby action code table when event output is used as an alarm and standby becomes necessary.
- ② Set and select code 4 when event output is used for control. However, note that setting 4 will turn event output OFF if input goes out of order.
- ③ When code 2 is selected, the standby function is put in action only when power is applied.
- ④ When code 3 is selected, standby function is put in action when power is applied and when SV in execution is changed.
- ⑤ When a standby code is changed while standby action is in execution, it may be possible for the standby action to be released.

- ⑥ No-standby action is where the alarm is output any time the measured value (PV) reaches the alarm action point whether power is applied or not.

### 7-4. Standby action code table

- 1: No standby action
- 2: Standby action only when power is applied
- 3: Standby action when power is applied or when changed to SV
- 4: Control mode (no standby)

## 8. Before starting up

Before operation, check the wiring and set the items listed below by the setting methods of the screen groups. However, for factory-set items and items already set by equipment manufacturers, preparation is unnecessary.

### (1) Checking of Wiring

Check that the wiring connected to the terminals is carried out properly.

### (2) Application of Operating Power

Apply operating power. The controller is energized and the data display and other lamps light.

### (3) Setting of Measuring range and input type

Select input type, code and register by (ENT) from the setting range codes of Mode 1 screen (1-22) "Measuring range selection setting screen." In the case of current and voltage input, the measuring range of lower limit values, higher limit values opposed to input signals and the position of decimal point will be set.

### (4) Setting of control type

In the case of ON-OFF (two positions) action, call the mode 1 (1-2) "Proportional band setting" screen and select and register OFF. If used with PID auto tuning, setting can remain unchanged.

### (5) Setting of Control Output Characteristics

Select either heating (RA) or cooling (DA) characteristics from mode 1 (1-17) "Control output characteristics setting" screen.

### (6) Setting of Event (EV1, EV2) Action Type

Select and register a code for either mode 1 (1-11, 1-13, 1-14, 1-16) "Alarm code" or "Alarm standby code".

**Note:** When input types, measuring range is selected and changed, all the set data concerning measuring range will be initialized.

## 9. Table of Measuring Range Codes

Input type		Code	Measuring range (°C)	Measuring range (°F)	
Multi	Thermocouple	B *1	01	0 ~ 1800	0 ~ 3300
		R	02 *2	0 ~ 1700	0 ~ 3100
		S	03	0 ~ 1700	0 ~ 3100
		K	04	-199.9 ~ 400.0	-300 ~ 750
			05	0.0 ~ 800.0	0 ~ 1500
			06	0 ~ 1200	0 ~ 2200
		E	07	0 ~ 700	0 ~ 1300
		J	08	0 ~ 600	0 ~ 1100
		T	09 *2	-199.9 ~ 200.0	-300 ~ 400
		N	10	0 ~ 1300	0 ~ 2300
		PLII *3	11	0 ~ 1300	0 ~ 2300
	WRe5-26*4	12	0 ~ 2300	0 ~ 4200	
	U *5	13 *2	-199.9 ~ 200.0	-300 ~ 400	
	L *5	14	0 ~ 600	0 ~ 1100	
	R.T.D.	Pt100	31	-200 ~ 600	-300 ~ 1100
			32	-100.0 ~ 100.0	-150.0 ~ 200.0
			33	-50.0 ~ 50.0	-50.0 ~ 120.0
			34	0.0 ~ 200.0	0.0 ~ 400.0
		JPt100	35	-200 ~ 500	-300 ~ 1000
36			-100.0 ~ 100.0	-150.0 ~ 200.0	
37			-50.0 ~ 50.0	-50.0 ~ 120.0	
38			0.0 ~ 200.0	0.0 ~ 400.0	
mV	-10~ 10	71	Initial value: 0.0 ~ 100.0 Span: 10 ~ 5000 count Position of decimal point: None 1, 2 or 3 digits on the right of decimal point Lower limit value < Higher limit value		
	0~ 10	72			
	0~ 20	73			
	0~ 50	74			
	10~ 50	75			
	0~100	76			
Voltage	V	-1~ 1	81		
		0~ 1	82		
		0~ 2	83		
		0~ 5	84		
		1~ 5	85		
		0~10	86		

Thermocouple B, R, S, K, E, J, T, N: JIS/IEC

R.T.D. Pt100: JIS/IEC JPt100/Former JIS

\*1 Thermocouple B: Accuracy guarantee not applicable to 400°C (752°F) and below.

\*2 Thermocouple K, T, U: Accuracy of those whose readings are below -100°C is ±1.0% FS

\*3 Thermocouple PLII PlatineI

\*4 Thermocouple WRe5-26 (ASTM988)

\*5 Thermocouple U, L (DIN 43710)

## 10. Maintenance and Troubleshooting

### 10-1. Procedure of Maintenance Replacement and Matters Be Attended to (Steps for replacing defective items)

- Confirmation of Model Code:  
Check the model code of the component part in trouble. (Open the control box, and you can find an appropriate code in the model label affixed to the instrument case.)
- Inquiry on Input Data:  
Ask the manufacturer if input data (control date of external

operation, event output, set value of position, etc. at the time when an error occurs) is necessary or not.

- Confirmation of Present Wiring Condition:  
Check and record the present wiring condition. Please note that in case input data is necessary for control, the same control operation as before is not possible with a replaced product unless such data is input.
- Confirmation of Present Input Data:  
When data is not known, call the input date for the product, check and record it. In case input data is required, the same control operation as before is not with a replaced product unless such data is input.
- Repair of Present Product or Procurement of New Product:  
In case the product in trouble is removable from the site of installation, remove and have it repaired. If it is not possible, arrange to acquire a new product for replacement.
- Setting before Starting Operation:  
When replaced by a new product, check the wiring, apply power and set items as described in 8. Before Starting Up.

### 10-2. Cause of Trouble and Troubleshooting

Problem	Cause	Remedy
① Error code is displayed.	Refer to "Error Codes, Causes and Remedies."	Refer to "Error Codes, Causes and Remedies."
② Displayed PV value seems to be incorrect.	① Set measuring range code is different from that of input sensor/input signal. ② Erroneous wiring to input terminals of sensor	① Check if set measuring range code is correct for input signal. ② Correct wiring to input terminals of sensor.
③ Display on the front panel goes out and the instrument does not operate.	① Problem with power supply and wiring connection. ② Deterioration of the product.	① Inspect portions related to power source and wire connection. Check wiring. ② Examine the product and repair or replace.
④ Key unable to be operated.	① Keylock is in effect. ② Deterioration of the product.	① Release keylock. ② Examine and repair or replace the product.
⑤ ON-OFF action of control output is too fast.	① ON-OFF is set for P of PID. ② Too small a value set for hysteresis of ON-OFF action.	① Change the OFF set for P to two-position type ON-OFF action. ② Increase the hysteresis value of ON-OFF action.

### 10-3. Error Codes, Causes and Remedies

#### Input measured value problems

Screen display	Problem	Cause	Remedy
HHHH (HHHH)	Higher limit side scale over	① A break of thermocouple input wiring ② A break of R.T.D. input wiring ③ Input measured value exceeded higher limit of measuring range by 10%.	① Check thermocouple input wiring for a possible break. ② Check R.T.D. input A wiring for a possible break. If wiring has no problem, replace R.T.D. ③ For voltage or current input, check the transmitting unit of measured values. Check if set code of measuring range is correct for input signal.
LLLL (LLLL)	Lower limit side scale over	Input measured value fell from lower limit of measuring range by 10%.	Check wiring of inversed polarity for measured value input.
b--- (b---)	A break of R.T.D. input wiring.	① A break of B ② Breaks of ABB	Check R.T.D. input terminals A, B and B for breaks. If wiring has no problem, replace R.T.D.
CJHH (CJHH)	Higher limit side scale over of cold junction (CJ) of thermocouple input.	Ambient temperature of the product has exceeded 80°C.	① Reduce ambient temperature to the level provided in the environment conditions for the product. ② In case ambient temperature has not exceeded 80°C, examine the product.
CJLL (CJLL)	Lower limit side scale over of cold junction (CJ) of thermocouple input.	Ambient temperature of the product has fallen to -20°C or lower.	① Raise ambient temperature to the level provided in the environment conditions for the product. ② In case ambient temperature has not fallen to -20°C, examine the product.

The contents of this manual are subject to change without notice.

Temperature and Humidity Control Specialists  
**SHIMADEN CO., LTD.**

Head Office: 2-30-10 Kitamachi, Nerima-Ku, Tokyo 179-0081 Japan

Phone: +81-3-3931-7891 Fax: +81-3-3931-3089

E-MAIL: exp-dept@shimaden.co.jp URL: http://www.shimaden.co.jp

PRINTED IN JAPAN