

JUMO dTRANS T01 HART®

Programmable 2-wire transmitter



B 707016.0
Operating Manual



Special features



II 1 G Ex ia IIC T6/T5/T4

II 2 G Ex ia IIC T6/T5/T4



The Declaration of Conformity (page 19) and the Type Examination Certificate (page 25) must be observed.



Type 707016/... corresponds to type 956556/....

Content

	Special features	2
1	Scope/Conformity with standards	5
2	Safety notes	6
3	Type designation/nameplates	9
4	Technical data	11
5	Installation	12
6	Maintenance	15
7	HART[®] interface	16
8	Setup program	17
9	Declaration of Conformity	19
10	Type Examination Certificate	25

1 Scope/Conformity with standards

Scope

The JUMO dTRANS T01 HART[®] Type 707016/... is a programmable 2-wire transmitter (head-mounted temperature transmitter) with HART[®] interface. It is used for the connection of resistance thermometers and thermocouples and is preferably installed inside terminal heads Form B.

Conformity with standards

The essential health and safety requirements have been fulfilled by compliance with:

- EN 61326-1: 2013
- EN 60079-0: 2012 + A11:2013
- EN 60079-11: 2012
- EN 60079-26: 2015

2 Safety notes

- Setting up and operation of the head-mounted temperature transmitter must be performed with the help of these operating instructions and the regulations and standards relating to it.
- The head-mounted temperature transmitter may be operated in equipment group “II” category “1 G” (Zone 0), in “II 2 G” (Zone 1) and in “II 3 G” (Zone 2).
- If the head-mounted temperature transmitter is operated in “II 2 G” (Zone 1) or in “II 3 G” (Zone 2), the sensor circuit may be placed in the “II 1 G” area (Zone 0).
- If the head-mounted temperature transmitter is operated in “II 1 G” (Zone 0), care must be taken that potentially explosive air/vapor mixtures only occur in atmospheric conditions. If no potentially explosive mixtures are present, or if additional measures have been taken according to EN 1127-1, the instruments may also be operated outside the atmospheric conditions, in accordance with the manufacturer’s specifications.

Atmospheric conditions
$-20\text{ °C} \leq T_a \leq +60\text{ °C}$
$0.8\text{ bar} \leq p \leq 1.1\text{ bar}$

If the operating conditions at the head-mounted temperature transmitter differ from those stated above, it must be noted that the transmitter (also in the event of a fault) does not warm up above 20 °C and that the operator is responsible for the safe operation of the system with regard to pressures / temperatures of the materials used.

- The configuration of the transmitter using the PC setup program via HART[®] modem may **not** be performed inside the hazardous area.
- The supply circuit must fulfil explosion protection Ex ia IIC. This is ensured by an Ex-i power supply/input isolating amplifier 707530. Ex-i power supply/input isolating amplifier 707530: Part No. 00577948

2 Safety notes

- Equipment for potentially explosive areas which contain hybrid mixtures has to be especially checked for this use. Hybrid mixtures are potentially explosive mixtures out of combustible gases, vapors, or mists with combustible dust. The operator bears the responsibility of checking if the equipment is suitable for such uses.
- For transmitters (housing material PC, encapsulation material PUR) or built-in heads, the compatibility of the instrument material with the measurement media must be ensured.
- The ambient temperatures must not exceed the limits specified in the table below.
- The head-mounted temperature transmitter must be set up in such a way as to achieve at least IP20 enclosure protection as per EN 60529.
- During setup and operation of the head-mounted temperature transmitter, care has to be taken that no electrostatic discharge can occur.

2 Safety notes

Extract from the EC Type Examination Certificate PTB 01 ATEX 2124

Head-mounted temperature transmitter 707016	II 1 G Ex ia IIC T6/T5/T4 II 2 G Ex ia IIC T6/T5/T4
Temperature range in "II 2 G" and "II 3 G"	T6: Tamb = -40 to +55 °C T5: Tamb = -40 to +70 °C T4: Tamb = -40 to +85 °C
Temperature range in "II 1 G"	T6: Tamb = -20 to +40 °C T5: Tamb = -20 to +50 °C T4: Tamb = -20 to +60 °C
Supply circuit maximum values at the terminals 1(+) and 2(-) internal inductance and capacitance	Ui = 30 V DC Ii = 100 mA Pi = 750 mW linear characteristic Li = negligible Ci = negligible
Sensor circuit maximum values at the terminals 3, 4, 5 and 6 internal inductance and capacitance Circuitry without lumped external inductance or capacitance Circuitry with lumped external capacitance and inductance Ex ia IIC Ex ia IIB, Ex ia IIA	Uo = 5 V DC Io = 5.4 mA Po = 6.6 mW linear characteristic Li = negligible Ci = negligible Lo = 1000 mH Co = 100 µF Lo = 100 mH; Co = 2 µF Lo = 100 mH; Co = 9.9 µF

3 Type designation/nameplates

JUMO dTRANS T01 HART®

(1) Basic version

707016	programmable 2-wire transmitter with HART® interface and Ex protection	
--------	---	---



(2) Input (programmable)

X	888	factory-set (Pt 100 DIN vI)
X	999	configuration to customer specification ^a

(3) Output (proportional DC current - programmable)

X	888	factory-set (4 – 20 mA)
X	999	configuration to customer specification (20 – 4 mA)

(4) Probe break/short circuit

X	888	factory set (positive protection)
X	999	configuration to customer specification (negative protection)

^a For configuration to customer specification, please specify probe type and range in plain text.

	(1)	/	(2)	-	(3)	-	(4)
Order code							
Order example	707016		888		888		888

Standard accessories

- 1 Operating Instructions 707016.0
- Fixing items (2 fastening screws, 2 compression springs, and 2 locking washers)

Accessories

- PC setup program, multilingual
- HART® modem USB
Part No. 00443447
- Ex-i power supply/input isolating amplifier (Data Sheet 707530)
Part No. 00577948

3 Type designation/nameplates

The nameplates shown below can be found on the transmitter housing.

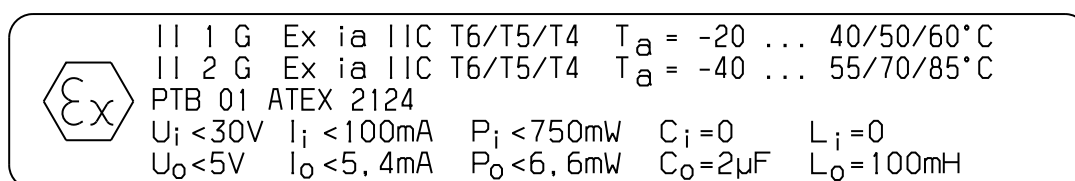
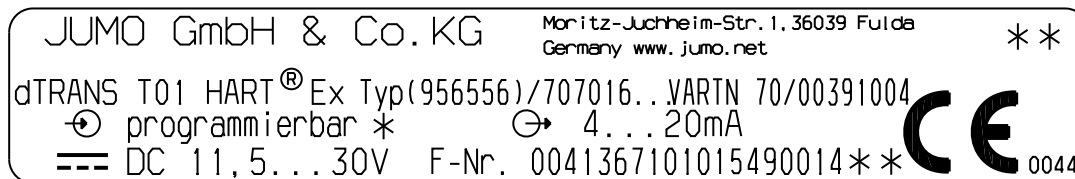

* or specification of range and sensor

** details on sales no. and serial number are specified as per order

The serial number (F-Nr.) indicates the production date (year/week), represented by the characters 12, 13, 14, 15.

Example:

F-Nr. 004136710101**549**0014

Accordingly, the transmitter was manufactured in week 49 of 2015.

4 Technical data

- Marking: Ex II 1 G Ex ia IIC T6/T5/T4
II 2 G Ex ia IIC T6/T5/T4
- EC Type Examination Certificate: PTB 01 ATEX 2124,
see Chapter 2 “Safety notes” and
Chapter 10 “Type Examination Certificate”
- Declaration of Conformity:
see Chapter 9 “Declaration of Conformity”
- Data Sheet: T 707010

5 Installation

The regulations according to ElexV and these operating instructions are essential for setting up and operating the transmitter. The maximum ambient temperature (see Chapter 2 “Safety notes”) must be observed.

Dimensions

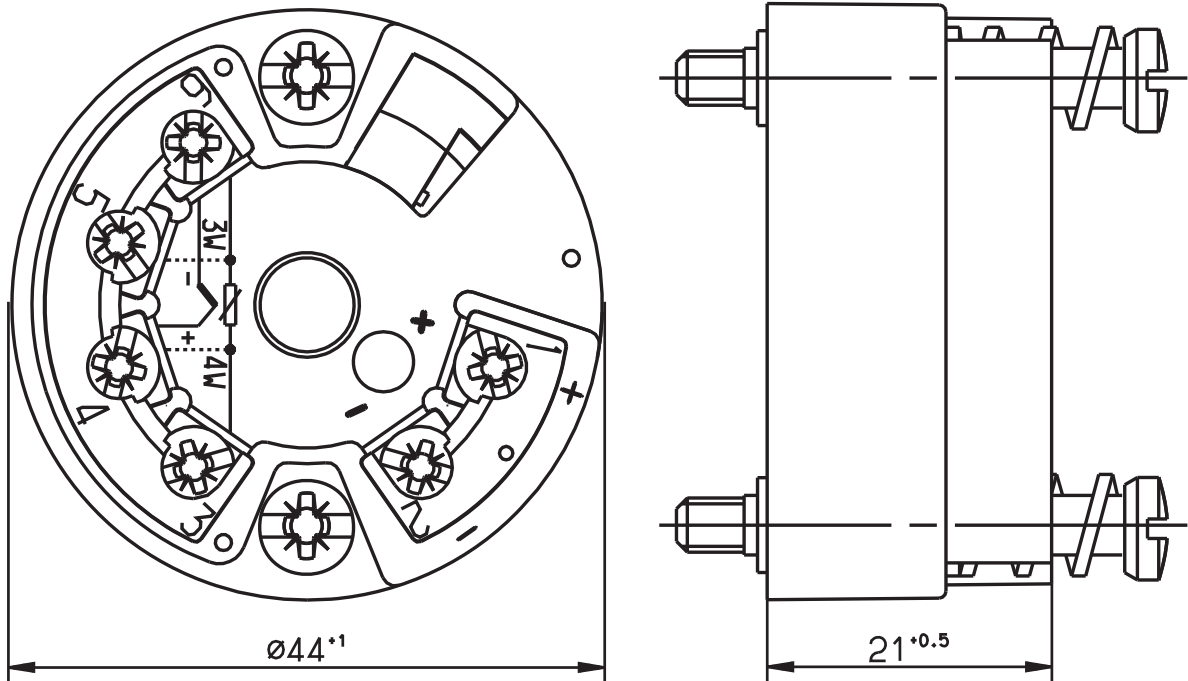

5 Installation

Connection diagram

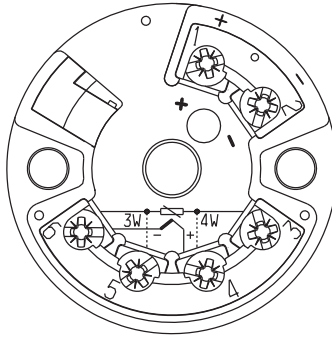

Connection for	Terminal assignment		
Supply voltage 11.5 – 30 V DC or current output 4 – 20 mA	+1	$R_B = \frac{U_b - 11.5V}{22mA}$ $R_B = \text{burden resistance}$ $U_b = \text{supply voltage}$	
Ex version only in conjunction with certified Ex transmitter supply unit!			
Analog inputs			
Resistance thermometer in 4-wire circuit	3 4 5 6	$R_L \leq 11 \Omega$ $R_L = \text{lead resistance per conductor}$	
Resistance thermometer in 3-wire circuit	3 5 6	$R_L \leq 11 \Omega$ $R_L = \text{lead resistance per conductor}$	
Resistance thermometer in 2-wire circuit	3 6	$R_L \leq 11 \Omega$ $R_L = \text{lead resistance per conductor}$	
Thermocouple	+4 -6		
Ex version: please note the connection data of the Ex input circuit!			

5 Installation

Connection example with Ex-i power supply/input isolating amplifier

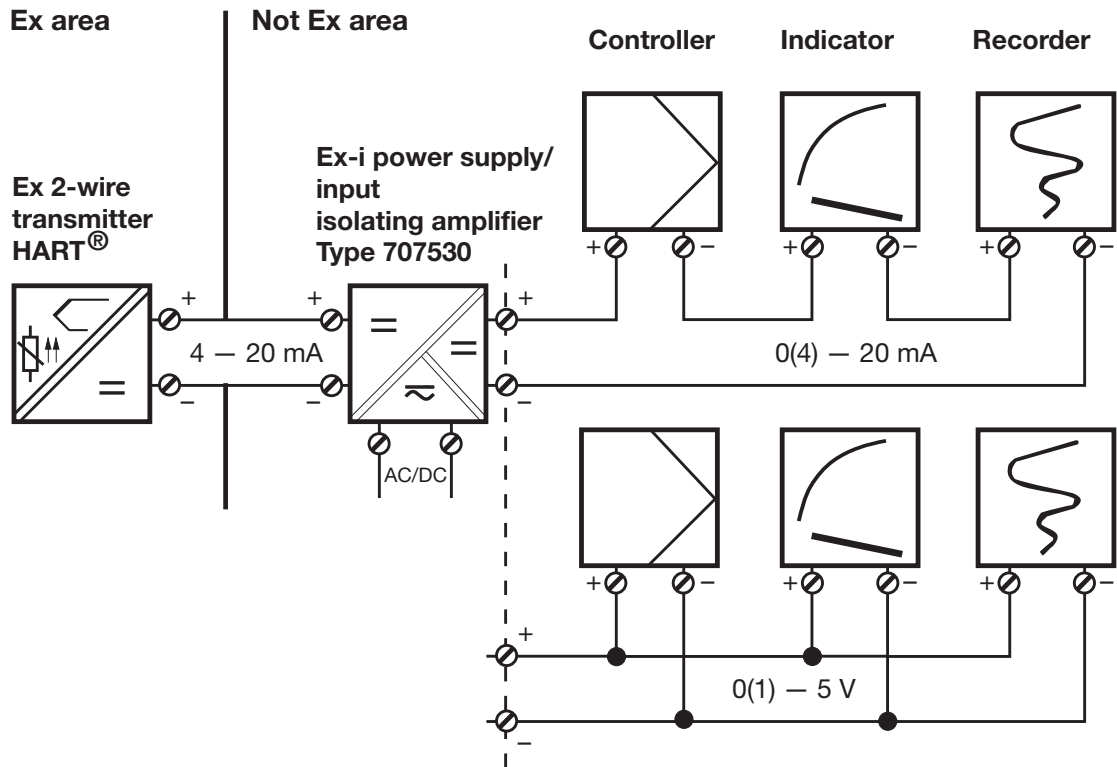

6 Maintenance

The regulations that apply to service, repair and testing must be observed. The maintenance work has to include a check, in particular of those parts which are critical for the explosion protection.

7 HART[®] interface

Connection of a HART[®] modem

The HART[®] modem USB is used to connect the transmitter to a PC. The modem is available on request, at extra cost:
Part No. 00443447

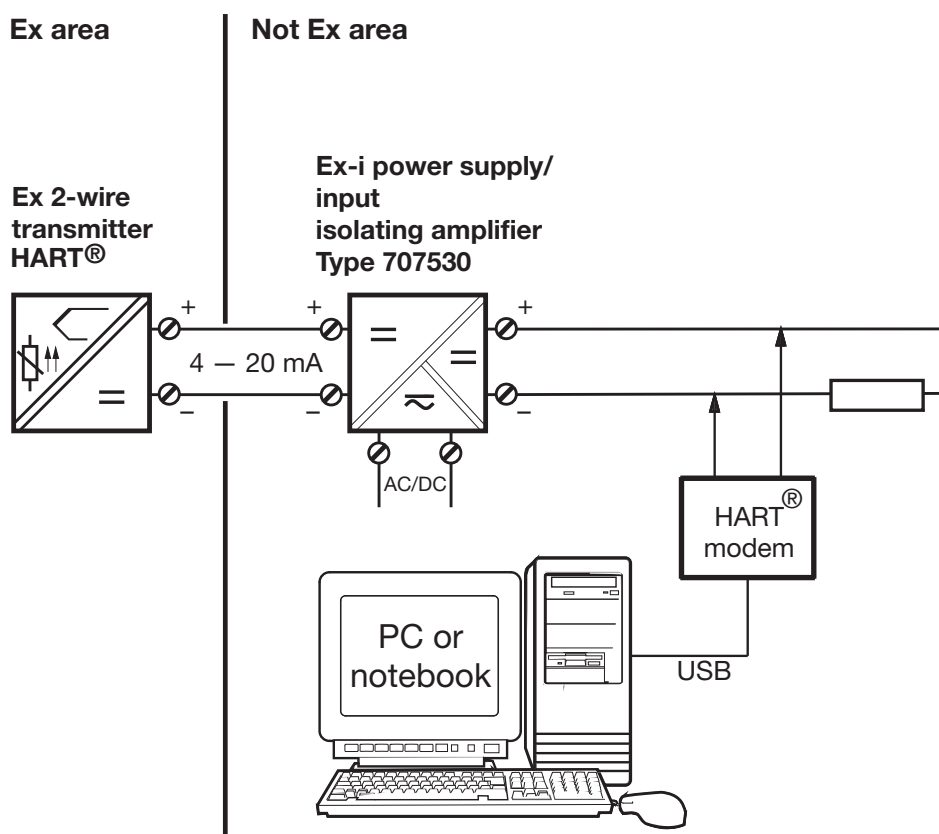

8 Setup program

The setup program is available for configuring the transmitter from a PC. Connection is via the HART[®] modem outside the hazardous (Ex) area.

Configurable parameters:

- TAG number (8 digits),
16 characters of description and
32 characters of message
- sensor type, linearization
- connection circuit (2-/3-/4-wire circuit)
- lead resistance with 2-wire circuit
- unit
- internal cold junction or
external cold junction (fixed value)
- custom linearization
- range limits
- output signal rising/falling (reversed)
- digital filter
- response to probe break/short-circuit
- measurement offset
- min. / max. value
- current simulation

8 Setup program

Hardware and software requirements

Installation and operation of the setup program requires a PC that fulfils the following conditions:

- Operating system: Microsoft¹ Windows 7, Windows 8, and Windows 10 (respectively 32-bit and 64-bit version)
- 1 USB interface

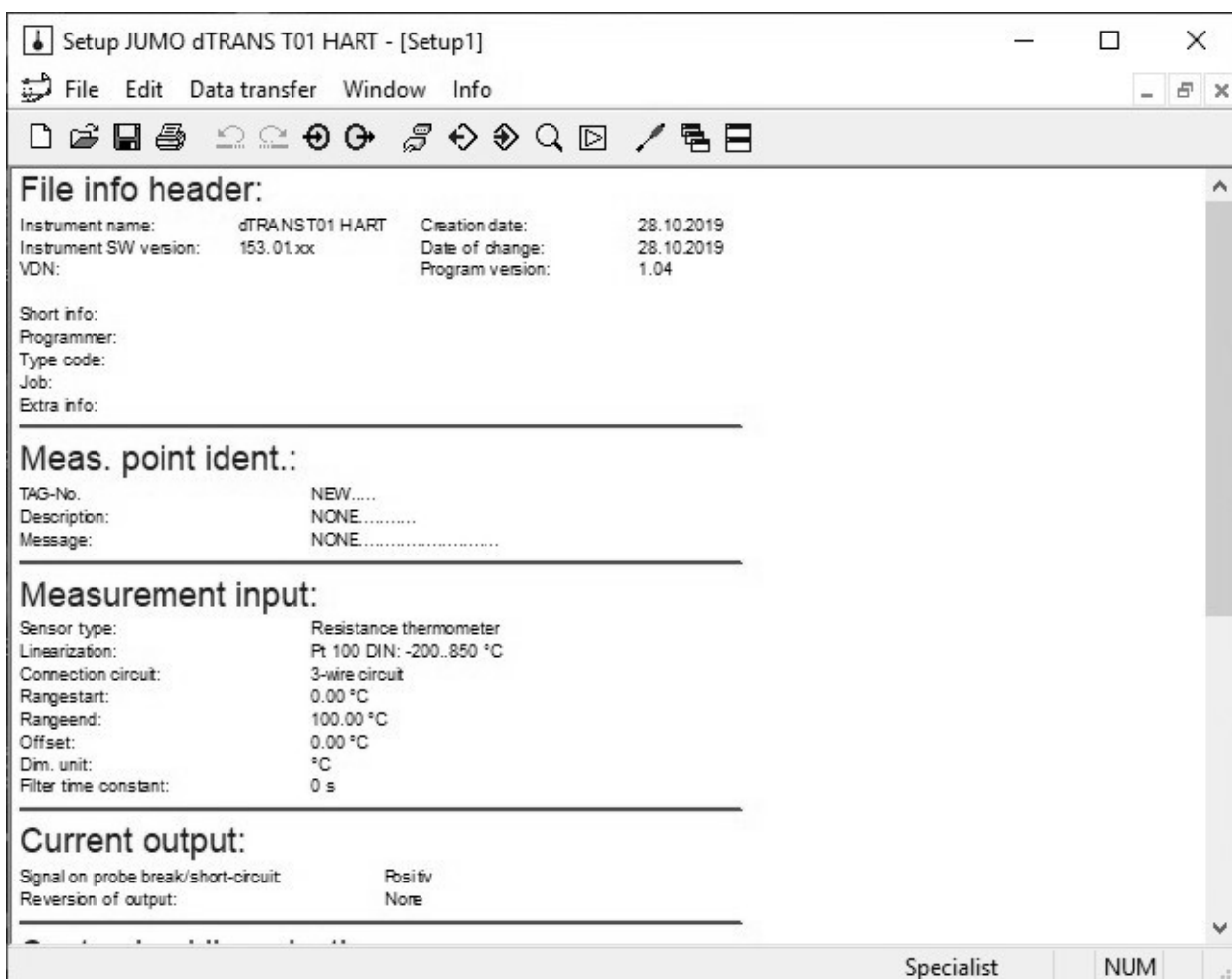

¹ Microsoft and Windows are registered trademarks of Microsoft Corporation.

9 Declaration of Conformity

JUMO GmbH & Co. KG

Moritz-Juchheim-Straße 1
36039 Fulda, Germany

Tel.: +49 661 6003-0
Fax: +49 661 6003-500

E-Mail: mail@jumo.net
Internet: www.jumo.net



More than **sensors + automation**

EU-Konformitätserklärung

EU declaration of conformity / Déclaration UE de conformité

Dokument-Nr.

CE 746

Document No. / Document n°.

Hersteller

JUMO GmbH & Co. KG

Manufacturer / Etabli par

Anschrift

Moritz-Juchheim-Straße 1, 36039 Fulda, Germany

Address / Adresse

Produkt

Product / Produit

Name

Name / Nom

Typ

Type / Type

Typenblatt-Nr.

Data sheet no. / N°

Document

d'identification

JUMO dTRANS T01 B-Kopf und HART 707011

707010

JUMO dTRANS T01 Tragschiene und 707013

707010

HART

JUMO dTRANS T01 Junior B-Kopf 707014

707010

JUMO dTRANS T01 B-Kopf und Ex 707015

707010

JUMO dTRANS T01 B-Kopf und Ex 707016

707010

und HART

Wir erklären in alleiniger Verantwortung, dass das bezeichnete Produkt die Anforderungen der Europäischen Richtlinien erfüllt.

We hereby declare in sole responsibility that the designated product fulfills the requirements of the European Directives.

Nous déclarons sous notre seule responsabilité que le produit remplit les Directives Européennes.

Dokument-Nr.

Document No. / Document n°.

CE 746

EU-Konformitätserklärung

Seite: 1 von 6

9 Declaration of Conformity

JUMO GmbH & Co. KG

Moritz-Juchheim-Straße 1
36039 Fulda, Germany

Tel.: +49 661 6003-0
Fax: +49 661 6003-500

E-Mail: mail@jumo.net
Internet: www.jumo.net



More than **sensors + automation**

Richtlinie 1

Directive / Directive

Name

EMC

Name / Nom

Fundstelle

2014/30/EU

Reference / Référence

Bemerkung

Comment / Remarque

Datum der Erstanbringung des CE-Zeichens 1999

auf dem Produkt

*Date of first application of the CE mark to the product / Date
de 1ère application du sigle sur le produit*

Angewendete Normen/Spezifikationen

Standards/Specifications applied / Normes/Spécifications appliquées

Fundstelle

Reference / Référence

EN 61326-1

Ausgabe

Edition / Édition

2013

Bemerkung

Comment / Remarque

Gültig für Typ

Valid for Type / Valable pour le type

707011/...

707013/...

707014/...

707015/...

707016/...

Dokument-Nr.
Document No. / Document n°.

CE 746

EU-Konformitätserklärung

Seite: 2 von 6

9 Declaration of Conformity

JUMO GmbH & Co. KG

Moritz-Juchheim-Straße 1
36039 Fulda, Germany

Tel.: +49 661 6003-0
Fax: +49 661 6003-500

E-Mail: mail@jumo.net
Internet: www.jumo.net



More than **sensors + automation**

Richtlinie 2

Directive / Directive

Name

ATEX

Name / Nom

Fundstelle

2014/34/EU

Reference / Référence

Bemerkung

Mod. B+D

Comment / Remarque

Datum der Erstanbringung des CE-Zeichens auf dem Produkt

2001

Date of first application of the CE mark to the product / Date de 1ère application du sigle sur le produit

Gültig für Typ

Valid for Type / Valable pour le type

707015/...

707016/...

EU-Baumusterprüfbescheinigung 2.1

EU type examination certificate / Certificat d'examen de type UE

Fundstelle

ZELM 99 ATEX 0018 X

Reference / Référence

Benannte Stelle

ZELM ex Prüf- und Zertifizierungsstelle

Notified Body / Organisme notifié

Kennnummer

0820

Identification no. / N° d'identification

Angewendete Normen/Spezifikationen

Standards/Specifications applied / Normes/Spécifications appliquées

Fundstelle

Reference / Référence

EN 60079-0

EN 60079-11

EN 1127-1

Ausgabe

Edition / Édition

2012+A11:2013

2012

2011

Bemerkung

Comment / Remarque

Gültig für Typ

Valid for Type / Valable pour le type

707015/...

Dokument-Nr.

Document No. / Document n°.

CE 746

EU-Konformitätserklärung

Seite: 3 von 6

9 Declaration of Conformity

JUMO GmbH & Co. KG

Moritz-Juchheim-Straße 1
36039 Fulda, Germany

Tel.: +49 661 6003-0
Fax: +49 661 6003-500

E-Mail: mail@jumo.net
Internet: www.jumo.net



More than **sensors + automation**

EU-Baumusterprüfbescheinigung 2.2

EU type examination certificate / Certificat d'examen de type UE

Fundstelle

PTB 01 ATEX 2124

Reference / Référence

Benannte Stelle

Physikalisch-Technische-Bundesanstalt (PTB)

Notified Body / Organisme notifié

Kennnummer

0102

Identification no. / N° d'identification

Angewendete Normen/Spezifikationen

Standards/Specifications applied / Normes/Spécifications appliquées

Fundstelle

Reference / Référence

Ausgabe

Edition / Édition

Bemerkung

Comment / Remarque

EN 60079-0

2012+A11:2013

EN 60079-11

2012

EN 60079-26

2015

Gültig für Typ

Valid for Type / Valable pour le type

707016/...

Anerkannte Qualitätssicherungssysteme der Produktion

Recognized quality assurance systems of production / Systèmes de qualité reconnus de production

Benannte Stelle

Notified Body / Organisme notifié

TÜV NORD CERT GmbH

Kennnummer

Identification no. / N° d'identification

0044

Dokument-Nr.

Document No. / Document n°.

CE 746

EU-Konformitätserklärung

Seite: 4 von 6

9 Declaration of Conformity

JUMO GmbH & Co. KG

Moritz-Juchheim-Straße 1
36039 Fulda, Germany

Tel.: +49 661 6003-0
Fax: +49 661 6003-500

E-Mail: mail@jumo.net
Internet: www.jumo.net



More than **sensors + automation**

Richtlinie 3

Directive / Directive

Name

RoHS

Name / Nom

Fundstelle

2011/65/EU

Reference / Référence

Bemerkung

Comment / Remarque

Datum der Erstanbringung des CE-Zeichens auf dem Produkt

2017

*Date of first application of the CE mark to the product / Date
de 1ère application du sigle sur le produit*

Angewendete Normen/Spezifikationen

Standards/Specifications applied / Normes/Spécifications appliquées

Fundstelle

Reference / Référence

Ausgabe

Edition / Édition

Bemerkung

Comment / Remarque

VDK Umweltrelevante Aspekte V1
bei der Produktentwicklung und
-gestaltung

Gültig für Typ

Valid for Type / Valable pour le type

707011/...

707013/...

707014/...

707015/...

707016/...

Dokument-Nr.
Document No. / Document n°.

CE 746

EU-Konformitätserklärung

Seite: 5 von 6

9 Declaration of Conformity

JUMO GmbH & Co. KG

Moritz-Juchheim-Straße 1
36039 Fulda, Germany

Tel.: +49 661 6003-0
Fax: +49 661 6003-500

E-Mail: mail@jumo.net
Internet: www.jumo.net



More than **sensors + automation**

Aussteller

Issued by / Etabli par

Ort, Datum

Place, date / Lieu, date

Rechtsverbindliche Unterschriften

Legally binding signatures /

Signatures juridiquement valable

JUMO GmbH & Co. KG

Fulda, 2018-08-30

Bereichsleiter Vertrieb Inland / Globales
Produkt- und Branchenmanagement
ppa. Dimitrios Charisiadis

Qualitätsbeauftragter und Leiter Qualitätswesen
i. V. Harald Gienger

Dokument-Nr.
Document No. / Document n°.

CE 746

EU-Konformitätserklärung

Seite: 6 von 6

10 Type Examination Certificate

Physikalisch-Technische Bundesanstalt

Braunschweig und Berlin

PTB



EG-Baumusterprüfbescheinigung

- (1) Geräte und Schutzsysteme zur bestimmungsgemäßen Verwendung in explosionsgefährdeten Bereichen - **Richtlinie 94/9/EG**
- (2) EG-Baumusterprüfbescheinigungsnummer
- (3) **PTB 01 ATEX 2124**
- (4) Gerät: Temperaturkopfmessumformer JUMO dTRANS T01 HART Ex Typ 956556/...
- (5) Hersteller: M. K. Juchheim GmbH & Co.
- (6) Anschrift: Moltkestr. 13/31, 36039 Fulda, Deutschland
- (7) Die Bauart dieses Gerätes sowie die verschiedenen zulässigen Ausführungen sind in der Anlage und den darin aufgeführten Unterlagen zu dieser Baumusterprüfbescheinigung festgelegt.
- (8) Die Physikalisch-Technische Bundesanstalt bescheinigt als benannte Stelle Nr. 0102 nach Artikel 9 der Richtlinie des Rates der Europäischen Gemeinschaften vom 23. März 1994 (94/9/EG) die Erfüllung der grundlegenden Sicherheits- und Gesundheitsanforderungen für die Konzeption und den Bau von Geräten und Schutzsystemen zur bestimmungsgemäßen Verwendung in explosionsgefährdeten Bereichen gemäß Anhang II der Richtlinie.
- Die Ergebnisse der Prüfung sind in dem vertraulichen Prüfbericht PTB Ex 01-21139 festgehalten.
- (9) Die grundlegenden Sicherheits- und Gesundheitsanforderungen werden erfüllt durch Übereinstimmung mit
- EN 50014:1997 + A1 + A2 EN 50020:1994 EN 50284:1999**
- (10) Falls das Zeichen „X“ hinter der Bescheinigungsnummer steht, wird auf besondere Bedingungen für die sichere Anwendung des Gerätes in der Anlage zu dieser Bescheinigung hingewiesen.
- (11) Diese EG-Baumusterprüfbescheinigung bezieht sich nur auf Konzeption und Bau des festgelegten Gerätes gemäß Richtlinie 94/9/EG. Weitere Anforderungen dieser Richtlinie gelten für die Herstellung und das Inverkehrbringen dieses Gerätes.
- (12) Die Kennzeichnung des Gerätes muß die folgenden Angaben enthalten:



II 1 G bzw. II 2 G EEx ia IIC T6/T5/T4

Zertifizierungsstelle Explosionsschutz
Im Auftrag

Braunschweig, 30. August 2001

Dr.-Ing. U. Johannsmeyer
Regierungsdirektor

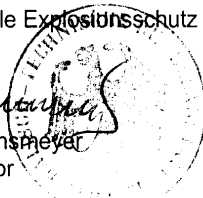

Seite 1/3

EG-Baumusterprüfbescheinigungen ohne Unterschrift und ohne Siegel haben keine Gültigkeit.
Diese EG-Baumusterprüfbescheinigung darf nur unverändert weiterverbreitet werden.
Auszüge oder Änderungen bedürfen der Genehmigung der Physikalisch-Technischen Bundesanstalt.

Physikalisch-Technische Bundesanstalt • Bundesallee 100 • D-38116 Braunschweig

10 Type Examination Certificate

Physikalisch-Technische Bundesanstalt

Braunschweig und Berlin



(13)

Anlage

(14)

EG-Baumusterprüfbescheinigung PTB 01 ATEX 2124

(15) Beschreibung des Gerätes

Der Temperaturkopfmessumformer JUMO dTRANS T01 HART Ex Typ 956556/... dient zur Umwandlung von Widerstands- und Spannungssignalen in ein Stromsignal 4 ... 20 mA. Dem Stromsignal wird ein digitales HART-Protokoll überlagert.

Der Zusammenhang zwischen der Gerätekategorie und den höchstzulässigen Umgebungstemperaturbereichen ist der folgenden Tabelle zu entnehmen:

	Kategorie 1	Kategorie 2
T6	40 °C	55 °C
T5	-20 °C ... 50 °C	-40 °C ... 70 °C
T4	60 °C	85 °C

Der Prozessdruck der Medien muss bei Anwendungen, die Kategorie-1-Betriebsmittel erfordern, zwischen 0,8 bis 1,1 bar liegen. Wird von diesen genannten Einsatzbedingungen am Temperaturkopfmessumformer abgewichen, ist zu beachten, dass der Temperaturkopfmessumformer (auch im Störfall) keine höhere Erwärmung als 20 K aufweist und dass der sichere Betrieb der Anlage im Hinblick auf Drücke/Temperaturen der verwendeten Stoffe dem Betreiber obliegt.

Elektrische Daten

Spannungsversorgung.....in Zündschutzart Eigensicherheit EEx ia IIC
nur zum Anschluss an bescheinigte eigensichere Stromkreise

Höchstwerte:

$$U_i = 30 \text{ V DC}$$

$$I_i = 100 \text{ mA}$$

$$P_i = 750 \text{ mW}$$

C_i vernachlässigbar klein

L_i vernachlässigbar klein

Sensorstromkreis.....in Zündschutzart Eigensicherheit EEx ia IIC

Höchstwerte:

$$U_o = 5 \text{ V DC}$$

$$I_o = 5,4 \text{ mA}$$

$$P_o = 6,6 \text{ mW}$$

Kennlinie linear

Seite 2/3

EG-Baumusterprüfbescheinigungen ohne Unterschrift und ohne Siegel haben keine Gültigkeit.
Diese EG-Baumusterprüfbescheinigung darf nur unverändert weiterverbreitet werden.
Auszüge oder Änderungen bedürfen der Genehmigung der Physikalisch-Technischen Bundesanstalt.

Physikalisch-Technische Bundesanstalt • Bundesallee 100 • D-38116 Braunschweig

10 Type Examination Certificate

Physikalisch-Technische Bundesanstalt



Braunschweig und Berlin

Anlage zur EG-Baumusterprüfbescheinigung PTB 01 ATEX 2124

C_i vernachlässigbar klein

L_i vernachlässigbar klein

Beschaltung **ohne** vorhandene konzentrierte
äußere Induktivitäten oder Kapazitäten:

$C_o = 100 \mu\text{F}$

$L_o = 1000 \text{ mH}$

Beschaltung **mit** vorhandenen konzentrierten
äußeren Kapazitäten und Induktivitäten:

	EEx ia		
	IIC	IIB	IIA
C_o	2 μF	9,9 μF	9,9 μF
L_o	100 mH	100 mH	100 mH

(16) Prüfbericht PTB Ex 01-21139

(17) Besondere Bedingungen

keine

(18) Grundlegende Sicherheits- und Gesundheitsanforderungen

werden durch die vorgenannten Normen erfüllt

Zertifizierungsstelle Explosionsschutz
Im Auftrag

Dr.-Ing. U. Johannsmeyer
Regierungsdirektor

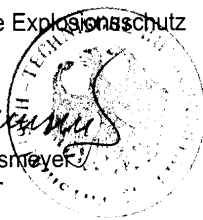

Braunschweig, 30. August 2001

Seite 3/3

EG-Baumusterprüfbescheinigungen ohne Unterschrift und ohne Siegel haben keine Gültigkeit.
Diese EG-Baumusterprüfbescheinigung darf nur unverändert weiterverbreitet werden.
Auszüge oder Änderungen bedürfen der Genehmigung der Physikalisch-Technischen Bundesanstalt.

Physikalisch-Technische Bundesanstalt • Bundesallee 100 • D-38116 Braunschweig

10 Type Examination Certificate

Physikalisch-Technische Bundesanstalt

Braunschweig und Berlin



1. ERGÄNZUNG

gemäß Richtlinie 94/9/EG Anhang III Ziffer 6

zur EG-Baumusterprüfbescheinigung PTB 01 ATEX 2124

Gerät: Temperaturkopfmessumformer JUMO dTRANS T01 HART Ex Typ 956556/...
und/oder 707016/...

Kennzeichnung:  II 1 G bzw. II 2 G EEx ia IIC T6/T5/T4

Hersteller: JUMO GmbH & Co. KG

Anschrift: Moltkestr. 13-31, 36039 Fulda, Deutschland

Beschreibung der Ergänzungen und Änderungen

Der Firmenname hat sich geändert und die Typenbezeichnung wurde ergänzt. Weitere Änderungen wurden nicht vorgenommen. Die Prüfungsunterlagen wurden überarbeitet und ergänzt.

Alle übrigen Angaben gelten auch für diese 1. Ergänzung.

Angewandte Normen

EN 50014:1997 + A1 + A2

EN 50020:1994

EN 50284:1999

Prüfbericht: PTB Ex 05-25049

Zertifizierungsstelle Explosionsschutz
Im Auftrag

Braunschweig, 4. April 2005

Dr.-Ing. U. Johanns
Regierungsdirektor



Seite 1/1

EG-Baumusterprüfbescheinigungen ohne Unterschrift und ohne Siegel haben keine Gültigkeit.
Diese EG-Baumusterprüfbescheinigung darf nur unverändert weiterverbreitet werden.
Auszüge oder Änderungen bedürfen der Genehmigung der Physikalisch-Technischen Bundesanstalt.
Physikalisch-Technische Bundesanstalt • Bundesallee 100 • 38116 Braunschweig, Deutschland

10 Type Examination Certificate

Physikalisch-Technische Bundesanstalt

Braunschweig und Berlin



2. SUPPLEMENT

according to Directive 94/9/EC Annex III.6

to EC-TYPE-EXAMINATION CERTIFICATE PTB 01 ATEX 2124

(Translation)

Equipment: Head-type temperature measuring transducer JUMO dTRANS T01 HART Ex type 707016/... and/or 956556/...

Marking:  II 1 G or II 2 G Ex ia IIC T6/T5/T4

Manufacturer: JUMO GmbH & Co. KG

Address: Moritz-Juchheim-Str. 1, 36039 Fulda, Germany

Description of supplements and modifications

In the future the head-type temperature measuring transducer JUMO dTRANS T01 HART Ex of type 707016/... and/or 956556/... may also be manufactured according to the test documents listed in the test report.

The marking of the equipment was adapted to the current state of the standards stated below.

Safety-related modifications were not carried out.

For relationship between equipment category and the permissible ambient temperature ranges, reference is made to the following table:

	Category 1	Category 2
T6	40 °C	55 °C
T5	-20 °C ... 50 °C	-40 °C ... 70 °C
T4	60 °C	85 °C

For applications requiring category-1 equipment the process pressure of the media shall range from 0.8 up to 1.1 bar. In case of a deviation from these operating conditions, it shall be considered that the temperature rise of the head-type temperature measuring transducer (also in case of fault) is kept below 20 K and that the operating company is responsible for the safe operation of the system with respect to the pressures / temperatures of the media used.

Sheet 1/2

EC-type-examination Certificates without signature and official stamp shall not be valid. The certificates may be circulated only without alteration. Extracts or alterations are subject to approval by the Physikalisch-Technische Bundesanstalt. In case of dispute, the German text shall prevail.

Physikalisch-Technische Bundesanstalt • Bundesallee 100 • 38116 Braunschweig • GERMANY

10 Type Examination Certificate



Physikalisch-Technische Bundesanstalt

Braunschweig und Berlin

2. SUPPLEMENT TO EC-TYPE-EXAMINATION CERTIFICATE PTB 01 ATEX 2124

Electrical data

Voltage supplytype of protection Intrinsic Safety Ex ia IIC
only for connection to certified intrinsically safe circuits

Maximum values:

$$U_i = 30 \text{ V DC}$$

$$I_i = 100 \text{ mA}$$

$$P_i = 750 \text{ mW}$$

C_i negligibly low

L_i negligibly low

Sensor circuit.....type of protection Intrinsic Safety Ex ia IIC

Maximum values:

$$U_o = 5 \text{ V DC}$$

$$I_o = 5.4 \text{ mA}$$

$$P_o = 6.6 \text{ mW}$$

linear characteristic

C_i negligibly low

L_i negligibly low

For permissible external reactances reference is made to the table:

Ex ia	IIC	IIB	IIA
C_o	2 μF	9.9 μF	9.9 μF
L_o	100 mH	100 mH	100 mH

All other specifications of the EC-type examination certificate apply without changes.

Applied standards

EN 60079-0:2006

EN 60079-11:2007

EN 60079-26:2004

Assessment and test report:

PTB Ex 09-29232

Zertifizierungssektor Explosionschutz

By order:

Dr.-Ing. U. Johannsmeyer
Direktor und Professor

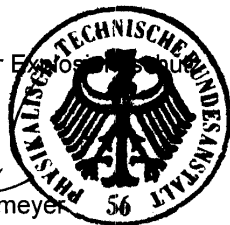

Braunschweig, December 3, 2009

Sheet 2/2

EC-type-examination Certificates without signature and official stamp shall not be valid. The certificates may be circulated only without alteration. Extracts or alterations are subject to approval by the Physikalisch-Technische Bundesanstalt. In case of dispute, the German text shall prevail.

Physikalisch-Technische Bundesanstalt • Bundesallee 100 • 38116 Braunschweig • GERMANY

10 Type Examination Certificate

Physikalisch-Technische Bundesanstalt

Braunschweig und Berlin



3. SUPPLEMENT

according to Directive 94/9/EC Annex III.6

to EC-TYPE-EXAMINATION CERTIFICATE PTB 01 ATEX 2124

(Translation)

Equipment: Head-type temperature measuring transducer JUMO dTRANS T01 HART Ex type 707016/... and/or type 956556/...

Marking:  II 1 G or II 2 G Ex ia IIC T6/T5/T4

Manufacturer: JUMO GmbH & Co. KG

Address: Moritz-Juchheim-Str. 1, 36039 Fulda, Germany

Description of supplements and modifications

In the future the head-type temperature measuring transducer JUMO dTRANS T01 HART Ex, type 707016/... and/or type 956556/... may also be manufactured and operated according to the test documents listed in the test report. The modifications concern the adaption to the current state of the standards as well as the specification of the operating voltage range on the type label. Technical modifications have not been made.

The marking and all other specifications of the EC-type examination certificate as well as the 1st and 2nd supplement apply without changes also to this 3rd supplement.

Applied standards

EN 60079-0:2009

EN 60079-11:2007

EN 60079-26:2004

Test report: PTB Ex 12-22197

Zertifizierungssektor Explosionsschutz
On behalf of PTB:

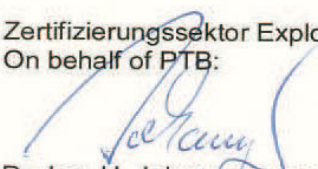
Dr.-Ing. U. Johannsmeyer
Direktor und Professor



Braunschweig, November 14, 2012

Sheet 1/1

EC-type-examination Certificates without signature and official stamp shall not be valid. The certificates may be circulated only without alteration. Extracts or alterations are subject to approval by the Physikalisch-Technische Bundesanstalt. In case of dispute, the German text shall prevail.

Physikalisch-Technische Bundesanstalt • Bundesallee 100 • 38116 Braunschweig • GERMANY

10 Type Examination Certificate



Physikalisch-Technische Bundesanstalt
Braunschweig und Berlin
Nationales Metrologieinstitut



4. SUPPLEMENT

according to Directive 94/9/EC Annex III.6

to EC-TYPE-EXAMINATION CERTIFICATE PTB 01 ATEX 2124

(Translation)

Equipment: Head-type temperature measuring transducer JUMO dTRANS T01 HART Ex
type 707016/... and/or type 956556/...

Marking:  II 1 G or II 2 G Ex ia IIC T6/T5/T4

Manufacturer: JUMO GmbH & Co. KG

Address: Moritz-Juchheim-Str. 1, 36039 Fulda, Germany

Description of supplements and modifications

In the future the head-type temperature measuring transducer JUMO dTRANS T01 HART Ex, type 707016/... and/or type 956556/... may also be manufactured and operated according to the test documents listed in the test report. The modifications concern the adaption to the current state of the standards as well as the revision of the type label (specification of manufacturer address). Technical modifications have not been made.

All further specifications of the EC-type examination certificate as well as the 1st through 3rd supplement apply without changes also to this 4th supplement.

Applied standards

EN 60079-0:2012 + A11:2013

EN 60079-11:2012

EN 60079-26:2015

Test report: PTB Ex 15-25225

Konformitätsbewertungsstelle, Sektor Explosionsschutz
On behalf of PTB

Braunschweig, November 26, 2015

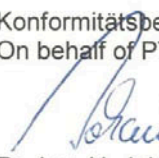
Dr.-Ing. U. Johannsmeyer
Direktor und Professor



Sheet 1/1

EC-type-examination Certificates without signature and official stamp shall not be valid. The certificates may be circulated only without alteration. Extracts or alterations are subject to approval by the Physikalisch-Technische Bundesanstalt. In case of dispute, the German text shall prevail.

Physikalisch-Technische Bundesanstalt • Bundesallee 100 • 38116 Braunschweig • GERMANY



JUMO GmbH & Co. KG

Street address:
Moritz-Juchheim-Straße 1
36039 Fulda, Germany
Delivery address:
Mackenrodtstraße 14
36039 Fulda, Germany
Postal address:
36035 Fulda, Germany
Phone: +49 661 6003-0
Fax: +49 661 6003-607
Email: mail@jumo.net
Internet: www.jumo.net

JUMO Instrument Co. Ltd.

JUMO House
Temple Bank, Riverway
Harlow, Essex, CM20 2DY, UK
Phone: +44 1279 63 55 33
Fax: +44 1279 62 50 29
Email: sales@jumo.co.uk
Internet: www.jumo.co.uk

JUMO Process Control, Inc.

6733 Myers Road
East Syracuse, NY 13057, USA
Phone: +1 315 437 5866
Fax: +1 315 437 5860
Email: info.us@jumo.net
Internet: www.jumousa.com

