

Intech Micro 2300-A8II analogue input station MODBUS RTU slave application supplementary manual.

MODBUS supplementary manual to the 2300-A8II Installation Guide.

The 2300 Series stations are designed to connect as slaves to MODBUS RTU masters such as PC's or PLC's to offer an economical I/O solution.

Intech Micro 2300 Series I/O stations:

- 2300-A8II** - 8 Isolated Current Inputs.
- 2300-A8VI** - 8 Isolated Voltage Inputs.
- 2300-Tc8** - 8 Isolated Thermocouple Inputs.
- 2300-RTD6** - 6 RTD Inputs.
- 2300-MULTI** - 2 RTD, 2 AI, 1 AO, 4 DI, 2 DO.
- 2300-D16** - 16 Digital Inputs.
- 2300-RO4** - 4 Relay Outputs.
- 2300-AO8I** - 8 Current Outputs.
- 2300-NET** - Isolated Ethernet TCP/IP to RS485.



Intech Micro 2300 Series - Connection Examples.

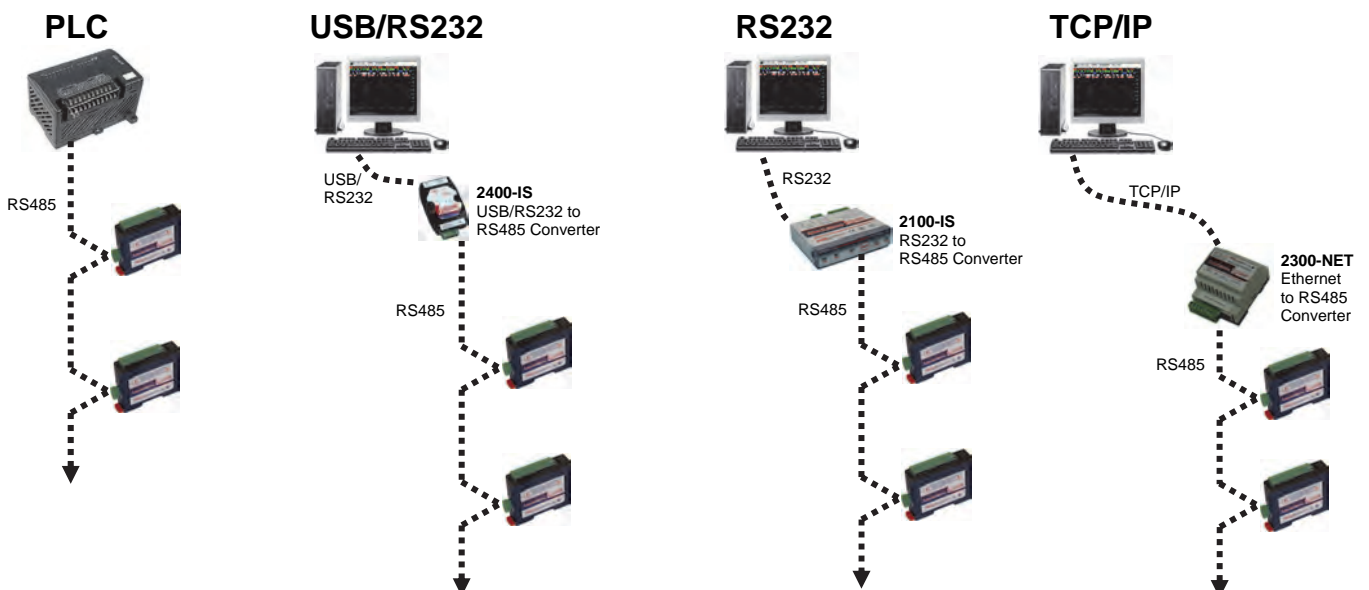

2300-A8II Specifications.

| | | | |
|------------------------|---|-------------|------------|
| Current Inputs: | -Input Points | 8 | |
| | -Input Current | 0(4)~20mA | |
| | -Input Type | Range | Resolution |
| | -1 | 0-4095 | 12 bits |
| | -2 | 0-20.000mA | 1uA |
| | -3 | +/-20.000mA | 1uA |
| | -Drift | 100ppm/°C | |
| -Isolation | 1000Vrms between field and logic 350Vpeak between each input | | |

| | | |
|--------------------|------------------------|--|
| Connectors: | -Logic Power and Comms | 4 Pin plug-in connector on side of station |
| | -Inputs | 18 Way screw plug-in connector on top of station |

| | | |
|---------------|------------|---|
| Comms: | -Protocols | RS485, Modbus RTU |
| | -Baud Rate | 2400, 4800, 9600, 19200, 38400, 57600, 115200 |
| | -Format | Parity: 0 = none, 1 = even, 2 = odd Stop Bits: 1 = 1 stop bit, 2 = 2 stop bits |

| | | |
|----------------------|-----------------------|-------------------------|
| Power Supply: | -Logic Supply Voltage | 12~24Vdc |
| | -Logic Supply Current | 58mA @ 12V / 31mA @ 24V |

Safety and EMC Compliances:

| | |
|-------------------|--|
| EMC Compliance | 89/336/EEC and Low Voltage Equipment Directive 73/23/EEC |
| Safety Compliance | IEC 950 |

General Specifications: (Unless otherwise stated in other input specifications).

| | | |
|-----------------------|--------------------------|---------------------------------|
| Operating Temperature | -10~50°C | |
| Storage Temperature | -40~85°C | |
| Operating Humidity | Up to 95% non condensing | |
| Housing | -Dimensions | L=97.5, W=22.6, H=109mm |
| | -Mounting | 35mm Symmetrical Mounting Rail. |

Note 1. Contact INTECH INSTRUMENTS for more detailed programming information.

Product Liability. This information describes our products. It does not constitute guaranteed properties and is not intended to affirm the suitability of a product for a particular application. Due to ongoing research and development, designs, specifications, and documentation are subject to change without notification. Regrettably, omissions and exceptions cannot be completely ruled out. No liability will be accepted for errors, omissions or amendments to this specification. Technical data are always specified by their average values and are based on Standard Calibration Units at 25C, unless otherwise specified. Each product is subject to the 'Conditions of Sale'.

Warning: These products are not designed for use in, and should not be used for patient connected applications. In any critical installation an independent fail-safe back-up system must always be implemented.

Modbus Register Types.

There are 4 types of variables which can be accessed from the station. Each station has one or more of these data variables.

| Type | Start Address | Variable | Access |
|------|---------------|---------------------------|-----------------------------|
| 1 | 00001 | Digital Outputs | Read & Write |
| 2 | 10001 | Digital Inputs | Read Only |
| 3 | 30001 | Input registers (Analog) | Read Only |
| 4 | 40001 | Output registers (Analog) | Read & Write (Holding type) |

Note: The Modbus message length must be limited to 100 consecutive read or write registers. If more registers are required then a new poll group must be added for the next xxx registers.

The 2300-A8II remote station has 8 isolated current inputs. The inputs are fully isolated from input to logic and between inputs. This station is ideal for monitoring existing 4~20mA current loops which are isolated from each other and cannot be connected to a common point of reference.

The standard setting for the 2300-A8II station is 0~20mA input current which represents an output value of 0 - 4095 (12 bits) in the corresponding Modbus register. To obtain an output value of 0 to 4095 for an input signal of 4 to 20mA the offset switch is switched on. This station can also be configured for a 0 - 20.000mA input range or +/- 20.000mA input. For an input signal of 0~20mA the offset switch is switched off (see *Dip Switch Settings* on page 14.21.M-5).

Communications Settings.

The data in the station is stored in 16 bit registers. These registers are accessed over the network using the MODBUS RTU communication protocol.

Communications Settings with DIP Switch 10 OFF (IOStudio Mode)

BAUD RATE 9600
DATA BITS 8
PARITY NONE
STOP BITS 1

Communications Settings with DIP Switch 10 ON (Programmed Baud Rate, MicroScan SCADA Factory Default)

BAUD RATE 2400, 4800, 9600, 19200, 38400, 57600, 115200
DATA BITS 8
PARITY None, Even, Odd
STOP BITS 1, 2

Note: To change these settings, download the free **IOStudio 2300 Series MODBUS Configuration** software via the link from the Intech website: www.intech.co.nz/2300

During this mode, DIP Switch 10 should be turned OFF so that the PC can communicate with the 2300 station using the IOStudio Mode communications settings. Once the Communications Settings are programmed, power down the 2300 station and change DIP Switch 10 to the ON position. Restore the power to the 2300 station and the configured Communications Settings will be ready for use.

Warning: Only program ONE 2300 station at a time!

Communications Settings Registers.

| | | | | | |
|-------|-------------|------|-------|-----|---|
| 40121 | Baud Rate | 2400 | 11520 | R/W | 2400, 4800, 9600, 19200, 38400, 57600, 115200 |
| 40122 | Parity | 0 | 2 | R/W | 0 = none, 1 = even, 2 = odd |
| 40123 | Stop Bits | 1 | 2 | R/W | 1 = 1 stop bit, 2 = 2 stop bits |
| 40124 | Reply Delay | 0 | 65535 | R/W | (x10ms) |

Baud Rate Register (40121)

The baud rate value is programmed directly into the baud rate register. The only exception is the 115200 baud rate where the value 11520 is used.

Parity Register (40122)

The parity can be set to none by writing a 0 to the parity register, set to even by writing a 1 to the parity Register or set to odd by writing a 2 to the parity register.

Stop Bits Register (40123)

The number of stop bits can be set to 1 by writing a 1 to the stop bits register or set to 2 by writing a 2 to the stop bits Register.

Reply Delay Register (40124)

The reply delay is a time delay between the Modbus message received to the reply being sent. In some applications where a modem or radio is used in the RS485 network, it may be necessary to add a reply delay due to turn around delays in the equipment.

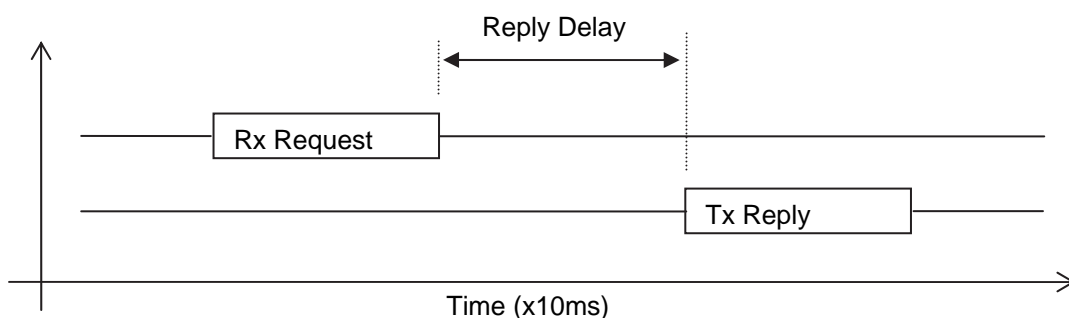

Status Indicators.

| | |
|----------------------|---|
| Power: | Flashes to indicate the CPU is running. |
| RS485 Rx: | Flashes to indicate the unit has received a valid Modbus message. |
| RS485 Tx: | Flashes to indicate the unit has sent a Modbus message. |
| Input Status: | <p>“ON” when the input is zero.</p> <p>“OFF” when the input is greater than zero and less than 4095.</p> <p>“Flashing” when the input is over range, greater or equal to 4095</p> |

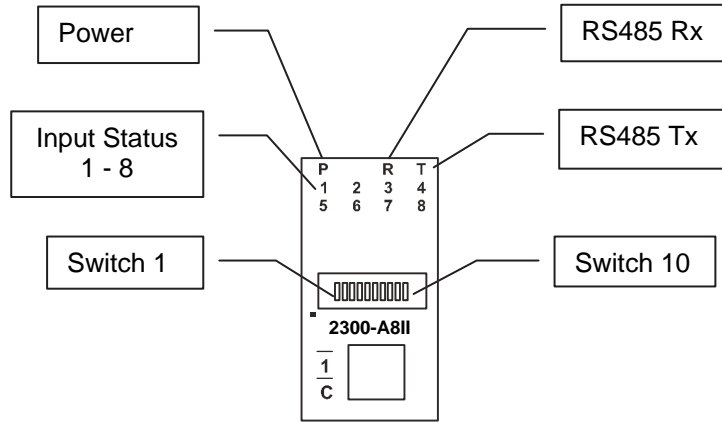

Power and RS485 Comms Wiring.

| Pin | Connection |
|-----|----------------|
| 81 | - 12Vdc @ 58mA |
| 82 | + 24Vdc @ 31mA |
| 71 | + Comms |
| 70 | - RS485 |

Warning: If the power/communication connections are reversed, the remote station may become faulty.

Wiring.

The following diagram shows how the analog inputs are connected to a 0(4)~20mA source. All of the common terminals are isolated from each other.

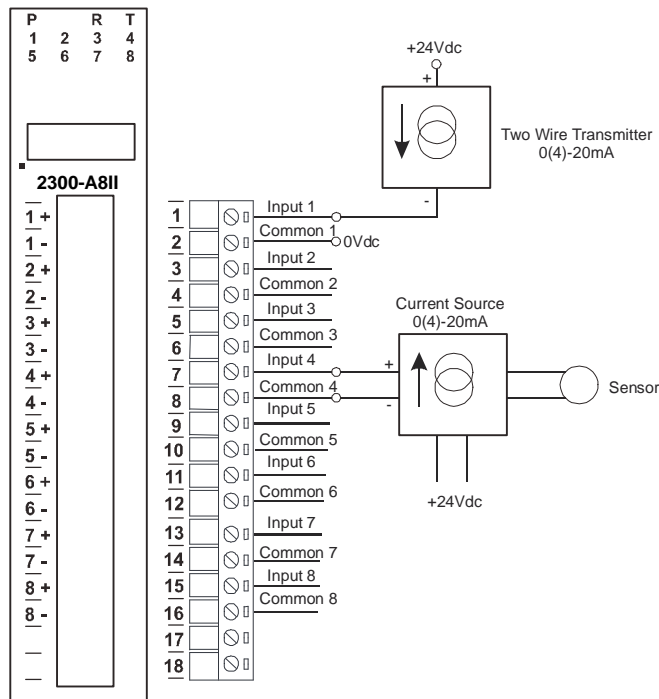

Dip Switch Settings.

| DIP SWITCH | FUNCTION | DESCRIPTION |
|------------|------------|--|
| 1 | STATION ID | +1 Station ID's from 0 to 127 are set up using switches 1 to 7 |
| 2 | STATION ID | +2 “ |
| 3 | STATION ID | +4 “ |
| 4 | STATION ID | +8 “ |
| 5 | STATION ID | +16 “ |
| 6 | STATION ID | +32 “ |
| 7 | STATION ID | +64 “ |
| 8 | OFF SET | When switched ON the inputs are scaled to accept a 4mA offset |
| 9 | BREAK | Input break. When switched OFF the analog value will be loaded with -32767 when the input is faulty. When switched ON the analog value will be loaded with 32768 |
| 10 | BAUD RATE | Selects 9600 in OFF position (IOStudio Mode) or Programmed Baud Rate in ON position (MicroScan SCADA Factory Default) See Page 3 'Communications Settings.' for more information. |

Note: See Installation Guide for the Station ID Table (Dip Switch Settings).

Data Registers.

| Modbus Address | Register Name | Low Limit | High Limit | Access | Description |
|----------------|---------------------------|-----------|------------|--------|--|
| 30001 | S/W Version / Module Type | N/A | N/A | R | High Byte = Software Version Low Byte = 107 |
| 30002 | Analog Input 1 | 0 | 4095 | R | Analog Input lower 12 Bits |
| 30003 | Analog Input 2 | 0 | 4095 | R | " |
| 30004 | Analog Input 3 | 0 | 4095 | R | " |
| 30005 | Analog Input 4 | 0 | 4095 | R | " |
| 30006 | Analog Input 5 | 0 | 4095 | R | " |
| 30007 | Analog Input 6 | 0 | 4095 | R | " |
| 30008 | Analog Input 7 | 0 | 4095 | R | " |
| 30009 | Analog Input 8 | 0 | 4095 | R | " |
| 30010 | Input Status | 0 | 65535 | R | bit2 = 0(open circuit or < 2), bit2 = 1(over range) bit1 = 0(OK), bit1 = 1(error) |
| 30100 | DIP Switch | 0 | 65535 | R | Status of DIP Switch on Front Panel |
| 40121 | Baud Rate | 2400 | 11520 | R/W | 2400, 4800, 9600, 19200, 38400, 57600, 115200 |
| 40122 | Parity | 0 | 2 | R/W | 0 = none, 1 = even, 2 = odd |
| 40123 | Stop Bits | 1 | 2 | R/W | 1 = 1 stop bit, 2 = 2 stop bits |
| 40124 | Reply Delay | 0 | 65535 | R/W | 0 = Disable, >0 = Enable. (x10ms) |

Analog Input Registers.

The analog inputs are read as a 12 bit value in the registers as follows:

| 2300-A8II ANALOG INPUTS | | | | | | | | | | | | | | ADDRESS | | |
|-------------------------|-------|------|------|------|------|-----|-----|-----|----|----|----|---|---|---------|-----|-------|
| MSB | | | | | | | | | | | | | | | LSB | |
| 15 | 14 | 13 | 12 | 11 | 10 | 9 | 8 | 7 | 6 | 5 | 4 | 3 | 2 | 1 | 0 | |
| 32768 | 16384 | 8192 | 4096 | 2048 | 1024 | 512 | 256 | 128 | 64 | 32 | 16 | 8 | 4 | 2 | 1 | 300XX |
| 0 | 0 | 0 | 0 | x | x | x | x | x | x | x | x | x | x | x | x | |

Analog Input: 12 Bit Value (0 - 4095)

Analog Input Status.

There are two status bits associated with each analog input. These bits are used to indicate if the input is zero or open circuit, in the working range 0-4095, or over range. If the input is open circuit or over range, then the error bit will be set. When the error bit is set, the range bit is zero if the input is open circuit and set if the input is over range, i.e.:

| <u>Bit 1- Error</u> | <u>Bit 2-Range</u> | <u>Condition</u> | <u>Status LED</u> |
|---------------------|--------------------|----------------------------|-------------------|
| 0 | don't care | Input working OK | (LED OFF) |
| 1 | 0 | Input Open circuit or zero | (LED ON) |
| 1 | 1 | Input Over range | (LED FLASH) |

The analog input status can be read in a single register as follows:

