

IN-VCC, Valve Current Controller.

Current Controller
for Control Valves.

Description.

The IN-VCC is a current control device used to interface between industrial process loops and SPORLAN (or similar) control valves.

The IN-VCC accepts a 4~20mA control signal and uses this to regulate the current applied to the SPORLAN valve. The range of the valve control current is 0~420mA, but is adjustable by using the Zero and Span trimpots.



Specifications.

Power Supply	24Vac, 16VA Transformer.
Input Signal	4~20mA.
Isolation Test Voltage	Input to Output; 1000Vdc for 1 min.
Output Signal	0~420mA Current Limited.
Maximum Output Power	16VA.
Operating Temperature	0~70C.
Storage Temperature	-20~80C.
Operating Humidity	5~85%RH Max. Non-Condensing.
Din Rail Mount	Fits all Available EN Rails.
Corrosion Proof	Cct Boards & Components by Isonel 642. (Except Terminals.)
Dimensions	L=78mm, W=68mm, H=65mm.

Product Liability. This information describes our products. It does not constitute guaranteed properties and is not intended to affirm the suitability of a product for a particular application. Due to ongoing research and development, designs, specifications, and documentation are subject to change without notification. Regrettably, omissions and exceptions cannot be completely ruled out. No liability will be accepted for errors, omissions or amendments to this specification. Technical data are always specified by their average values and are based on Standard Calibration Units at 25C, unless otherwise specified. Each product is subject to the 'Conditions of Sale'.

Warning: These products are not designed for use in, and should not be used for patient connected applications. In any critical installation an independent fail-safe back-up system must always be implemented.

Connection Diagram for Intech Valve Current Controller.

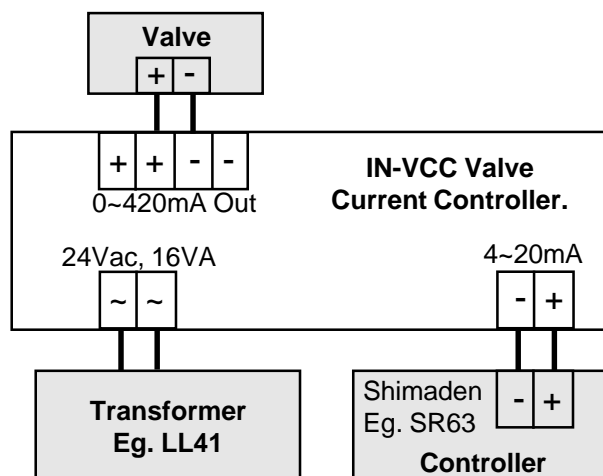

Quality Assurance Programme.

The modern technology and strict procedures of the ISO9001 Quality Assurance Programme applied during design, development, production and final inspection grant long term reliability of the instrument.

Intech INSTRUMENTS LTD
www.intech.co.nz
 Christchurch Ph: +64 3 343 0646
 Auckland Ph: 09 827 1930
 Email: sales@intech.co.nz