

PAC04 10A, 20A, 40A

- Built-in heat sink & Slim model
- DIN rail mountable
- Current Capacity: 10A / 20A / 40A
- Terminal Cover for greater safety
- LED indicator turns on when operation



SPECIFICATIONS

| | |
|---|---|
| Power Supply: | 100~240V 50 / 60Hz |
| Operational Load Voltage Range: | 50~264V 50 / 60Hz |
| Current Capacity: | 10A, 20A, 40A (Ambient Temperature below 40°C) |
| Control Input: | |
| Control Voltage: | 4.5~32V DC |
| Off Voltage: | 1.0V DC max |
| Input Impedance: | 1.5~8kΩ ±20% (I _{in} less than 5mA, Operating Temperature 25°C) |
| Control Element: | Triac |
| Control Mode: | Zero voltage switching |
| Output Characteristics: | |
| Leakage Current (when output 'OFF'): | 12mA max |
| Voltage Drop (when output 'ON'): | 1.5V max |
| Minimum Operational Current: | 100mA |
| Operational Lamp: | Red LED lamp |
| Insulation Resistance: | Between input/output terminals and housing case 500V DC 100 MΩ min |
| Dielectric strength: | Between input/output terminals and housing case 2500V AC 1 minute |
| Operational Ambient Temperature: | -20~80°C |
| Storage temperature: | -30~100°C |
| Weight: | 240g (10A) 320g (20A) 420g (40A) |

ORDERING CODE (PAC04 Solid State Relay with Radiating Fin)

| ITEM | CODE | SPECIFICATIONS |
|------------------|--------|--|
| SERIES | PAC04- | Zero Voltage Switching Control, Solid State Relay with Radiating Fin |
| CURRENT CAPACITY | 010- | 10A |
| | 020- | 20A |
| | 040- | 40A |
| REMARKS | 0 | Without |
| | 9 | With(Please consult before ordering.) |

AMBIENT TEMPERATURE & LOAD CURRENT CHARACTERISTIC

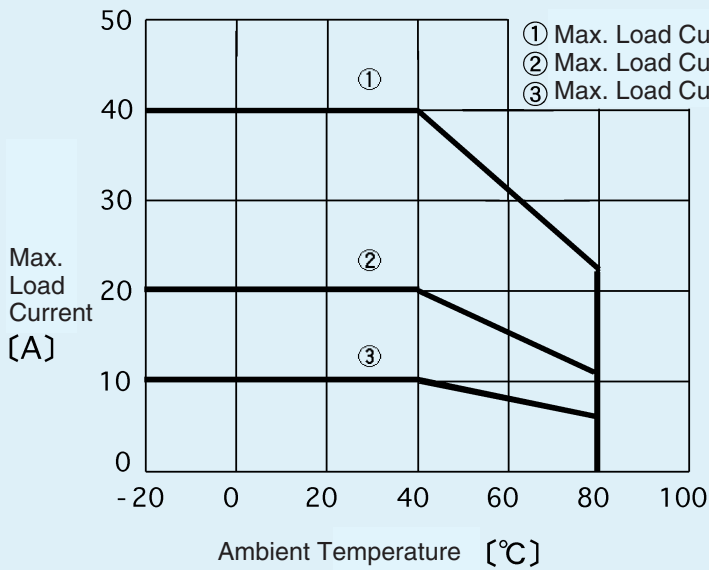

Be sure to provide enough ventilation to prevent the temperature increase. Heat generated by PAC04 is lead from following equation:

$$\text{Heat Value (W)} = 1.5 \text{ (V)} \times \text{Load Current (A)}$$

- * Voltage Drop (when output 'ON'): 1.5V max
- * Vertical mounting is recommended.

WIRING EXAMPLE

1. In case of with controller with SSR drive voltage output

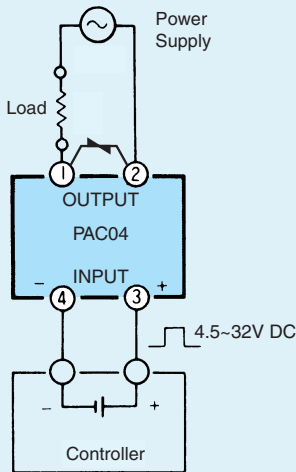

2. In case of with controller with contact output

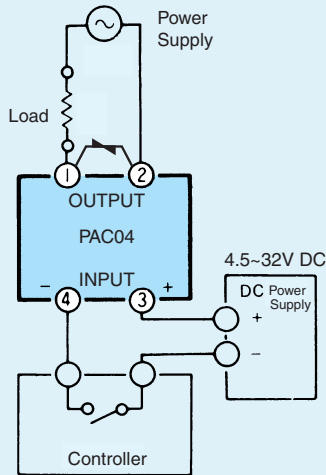

3. Three phase circuit Control of Delta or Star circuit with 2 units of PAC04

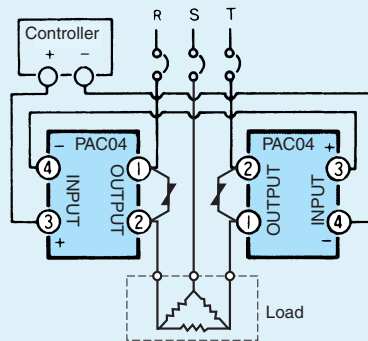

In case of with Shimaden "SR" Series controller, please configure it in series shown as above

* Make sure to connect "Ceramic Barister" between terminal 1 and 2 for the prevention of surge

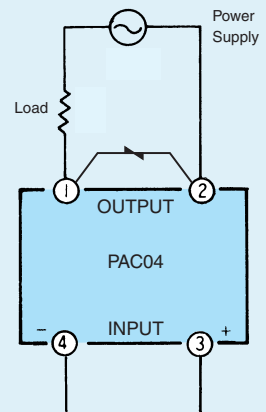

EXTERNAL DIMENSIONS & WEIGHT

10A Type

Weight: Approx. 240g

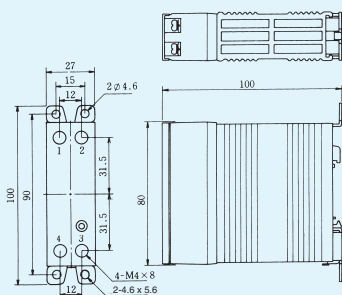

20A Type

Weight: Approx. 320g

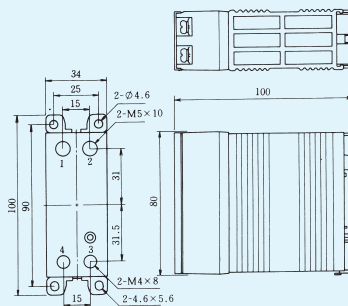

40A Type

Weight: Approx. 420g

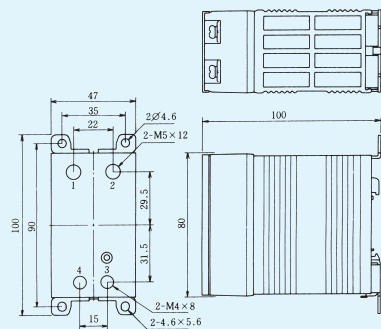

Note: When more than 2 units are mounted together without space, 90% of rated load current at maximum.
 Note: When a unit is mounted horizontally, 90% of rated load current at maximum.

Unit : mm

 **Warning**

- This product is designed for controlling the power of a heater or similar equipment used in a general industrial facilities. (It is not to be used for any purpose which regulates the prevention of serious effects on human life or safety.)

 **Caution**

- If the possibility of loss or damage to your system or property as a result of failure of any part of the process exists, proper safety measures must be made before the instrument is put into use so as to prevent the occurrence of trouble.



ISO 9001

(The contents of this brochure are subject to change without notice.)

Temperature and Humidity Control Specialists

SHIMADEN CO., LTD.

Head Office: 2-30-10 Kitamachi, Nerima-Ku, Tokyo 179-0081 Japan
Phone: +81-3-3931-7891 Fax: +81-3-3931-3089
E-MAIL: exp-dept@shimaden.co.jp URL: <http://www.shimaden.co.jp>

Distributed in New Zealand by:

Intech INSTRUMENTS LTD

Christchurch Auckland www.intech.co.nz
Ph: +6433430646 098271930
Fx: +6433430649 098271931 sales@intech.co.nz