

## ■ Preface

Thank you for purchasing our product. Before you start to operate the product, please read the following precautions at first, and use the product safely and carefully.

This Quick Reference aims to summarize the Instruction Manual. For further information like supported parameters, initial/default values, and so on, please refer to the Instruction Manual (PDF format file) in "SR23/FP23 Support CD".

## ■ Contents

■ Safety Precautions .....	1
■ Precautions for Installation Site .....	1
■ Precautions for Wiring .....	1
■ External Dimensions .....	2
■ Panel Cutout Dimensions .....	2
■ Mounting.....	2
■ Rear Terminal Arrangement Diagrams.....	2
■ Wiring Example of Open Collector Output.....	2
■ Names and Functions of Parts on Front Panel.....	3
■ Error Messages .....	3
■ LCD Flow Chart.....	4
■ Frequently-used Keys for LCD .....	4

## ■ Safety Precautions



### Warning

The FP23 Series Digital Controller is designed for controlling temperature, humidity and other physical quantities in general industrial facilities. It must not be used in any way that may adversely affect the safety, health or working conditions of those who come into contact with the effects of its use. When used, adequate and effective safety countermeasures must be provided at all times by the user. No warranty, express or implied, is valid when this device is used without the proper safety countermeasures.



### Warning

- Before you start to use this device, install it in a control panel or the like and avoid touching the terminals.
- Do not open this device's case, and touch the boards or inside of the case with your hands or a conductor. The user should never repair or modify this device. Doing so might cause an accident that may result in death or serious bodily injury from electric shock.
- This servo output product is a proportional controller for a control motor with limit switches. Do not use it for a motor without limit switches, or a motor with a misaligned limit switch, because a failure or damage might happen to the motor.



### Caution

To avoid damage to connected peripheral devices, facilities or the product itself due to malfunction of this device, safety countermeasures such as proper installation of the fuse or installation of overheating protection must be taken before use. No warranty, express or implied, is valid in the case of use resulting in an accident without having taken the proper safety countermeasures.

- The warning mark on the plate affixed on the casing of this device warns you not to touch charged parts while this device is powered ON. Doing so might cause an electric shock.
- A means for turning the power OFF such as switch or a breaker must be installed on the external power circuit connected to the power terminal on this device. Fasten the switch or breaker at a position where it can be easily operated by the operator, and indicate that it is a means for powering this device OFF.
- This device does not have a built-in fuse. Install a fuse that conforms to the following rating in the power circuit connected to the power terminal.  
**Fuse rating/characteristics: 250 VAC 1.0A/medium lagged or lagged type**
- When wiring this device, tighten the terminal connections firmly.
- Use the device with the power voltage and frequency within their rated ranges.
- Do not apply a voltage or current outside of the input rating to the input terminal. Doing so might shorten the service life of this device or cause it to malfunction.
- The voltage and current of the load connected to the output terminal should be within the rated range. Exceeding this range may cause the temperature to rise which might shorten the service life of this device or cause it to malfunction.
- This device is provided with ventilation holes for heat to escape. Prevent metal objects or other foreign matter from entering these ventilation holes as this may cause this device to malfunction. Do not block these ventilation holes or allow dirt and dust to stick to these holes. Temperature buildup or insulation failure might shorten the service life of this device or cause it to malfunction.
- Repeated tolerance tests on voltage, noise, surge, etc. may cause this device to deteriorate.
- Never remodel this device or use it a prohibited manner.
- To ensure safe and proper use of this device, and to maintain its reliability, observe the precautions described in this manual.
- Do not operate the keys on the front panel of this device with a hard or sharp-tipped object. Be sure to operate the keys with your fingertips.
- When cleaning this device, do not use paint thinner or other solvents. Wipe gently with a soft, dry cloth.

## ■ Precautions for Installation Site



### Caution

Do not use this device in the following sites. Doing so might result in malfunction or damage to this device and in some cases cause fire and/or dangerous situations.

- Locations that are filled with or generate inflammable gas, corrosive gas, dirt and dust, smoke, etc.
- Locations that are subject to water droplets, direct sunlight or strong radiated heat from other equipment
- Locations where the ambient temperature falls below -10°C or rises above 50°C
- Locations where dew condensation forms and the humidity reaches 90% or more
- Near equipment that generates high-frequency noise
- Near heavy current circuits or locations likely to be subject to inductive interference
- Locations subject to strong vibration and impact
- Locations exceeding an elevation of 2000 m

## ■ Precautions for Wiring

### Caution

- To prevent electric shock, always turn off and disconnect this device from the power supply before starting wiring.
- Do not touch wired terminals or charged parts with your hands while the power is supplied.

Pay attention to the following points when performing wiring:

- Check that the wiring is free from mistakes according to "■ Rear Terminal Arrangement Diagrams."
- Use crimped terminals that accommodate an M3 screw and that have a width of 6.2 mm or less.
- For thermocouple input, use a compensation wire compatible with the type of thermocouple.
- For RTD input, the resistance of a single lead wire must be 10Ω or less and the three wires must have the same resistance.
- The input signal lead must not be passed along the same conduit or duct as that for high-voltage power lines.
- Shield wiring (single point grounding) is effective against static induction noise.
- Short interval twisted pair wiring is effective against electromagnetic induction noise.
- When wiring, use wire or cable (minimum 1 mm<sup>2</sup> cross-sectional area) of 600 V grade PVC insulated wire or equivalent wire having the same rating.
- For wiring the ground, ground the ground terminal with the earth resistance at less than 100Ω and with wire 2 mm<sup>2</sup> or thicker.
- Two earth terminals are provided, each connected internally. One is for the ground connection, and the other is for connecting the shield of the signal lead. Do not use the earth terminals for crossover wiring of the power system ground lead.
- If this device is considered as being susceptible to noise caused by the power supply, attach a noise filter to prevent abnormal functioning. Install a noise filter onto a grounded panel, and make the wire connecting the noise filter output and the power supply terminal on this controller as short as possible.

Distributed in New Zealand by:

**Intech** INSTRUMENTS LTD

Christchurch Auckland [www.intech.co.nz](http://www.intech.co.nz)  
Ph: +6433430646 098271930  
Fx: +6433430649 098271931 [sales@intech.co.nz](mailto:sales@intech.co.nz)

## External Dimensions

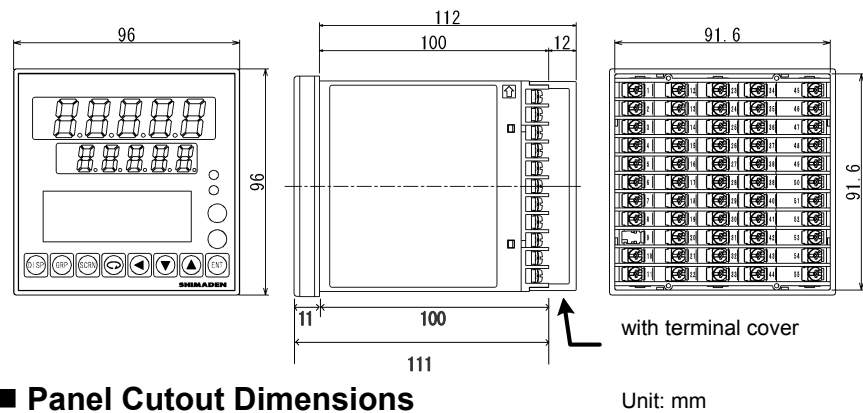

## Panel Cutout Dimensions

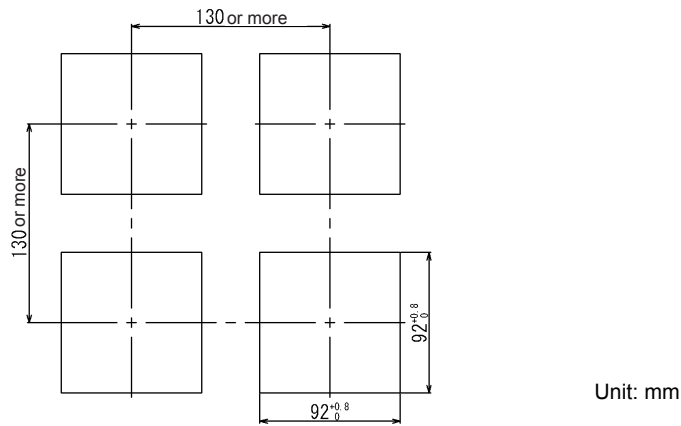

## Mounting



## Caution

To ensure safety and maintain the functions of this device, do not disassemble this device.  
If this device must be disassembled for replacement or repair, contact your dealer.

Follow the procedure below to mount this device on a panel.

1. Drill mounting holes referring to the panel cutout dimensions described in the previous section.  
The applicable thickness of the mounting panel is 1.0 to 8.0 mm.
2. Press this device into the panel from the front of the panel.
3. Insert the mounting fixtures at the top and bottom of this device, and tighten the screws from behind to fasten the device in place.
4. Over-tightening the screws may deform or damage the device housing.  
Take care not to tighten the screws too tight.

5. After completing wiring after installation, attach the terminal cover.

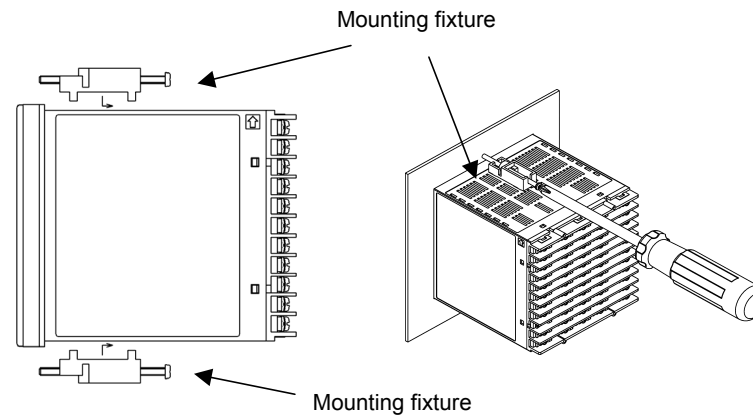

## Wiring Example of Open Collector Output

The following is an example of wiring open collector output for external control output terminals (DO).

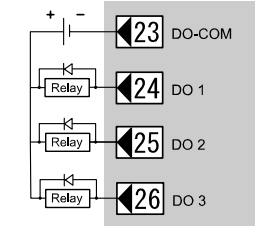

DO1 to DO3: Darlington output  
Output rating: 24V DC 50mA max.

### DO terminals other than DO1 to DO3

All the terminals other than DO1 to DO3 are open collector output terminals (24V DC 8mA max.).

Note that the output ratings differ from that of DO1 to DO3.

## Rear Terminal Arrangement Diagrams

Contact output type

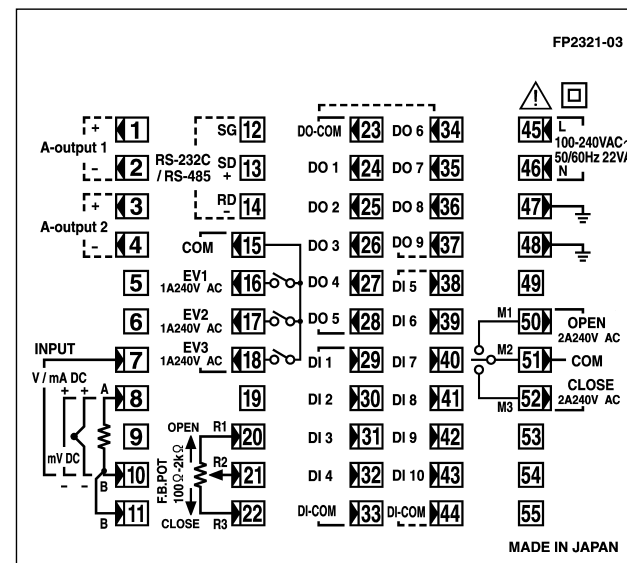

SSR output and contact output type

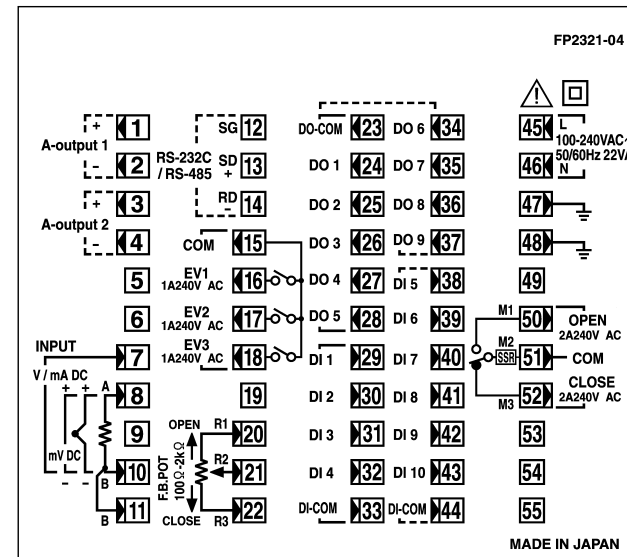

Terminal No	Symbol	Description
1	+	Analog output 1 (optional)
2	-	
3	+	Analog output 2 or Sensor power supply (optional)
4	-	
5		NC
6		
8	+	mV, thermocouple input
10	-	
8	A	RTD input
10	B	
7	+	V, mA input
10	-	
45	L	Power supply
46	N	
47		Grounding (internal shorting across terminals)
48		
49		NC
50	M1	Control output
51	M2	
52	M3	
53		NC
54		
55		
23	COM	External control output DO (standard)
24	DO1	
25	DO2	
26	DO3	
27	DO4	
28	DO5	Open collector output

Terminal No	Symbol	Description
29	DI1	External control output DI (standard)
30	DI2	
31	DI3	
32	DI4	
33	COM	
34	DO6	External control output DO (optional)
35	DO7	
36	DO8	
37	DO9	
38	DI5	External input DI5 to DI10 (optional)
39	DI6	
40	DI7	
41	DI8	
42	DI9	
43	DI10	
44	COM	
12	SG	Communication function (optional)
13	SD +	
14	RD -	
15	COM	Event output
16	EV1	
17	EV2	
18	EV3	
19		NC
20	R1	Feedback potentiometer input
21	R2	
22	R3	

A receiving resistor of 1/2W 250Ω 0.1% is attached across input terminals (7-10) for use for the 0 to 20mA, and 4 to 20mA inputs.

## Names and Functions of Parts on Front Panel

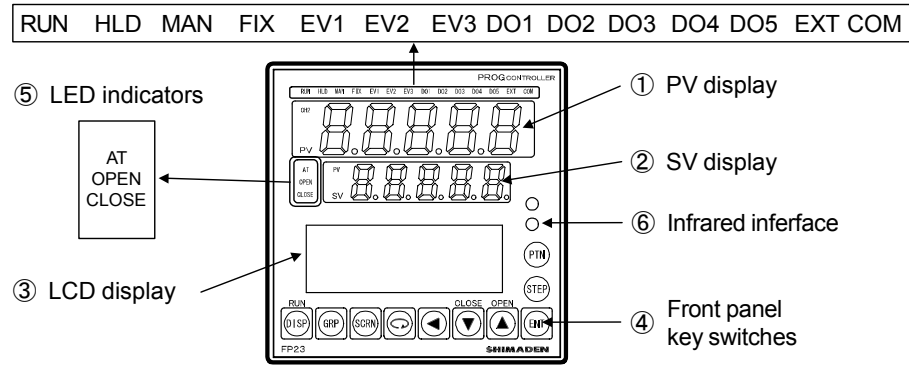

### ① PV display

Displays the measured value (PV).

Displays an error message when an error (e.g. scale over) occurs.

### ② SV display

Displays the target set value (SV).

### ③ LCD display (21 characters x 4 lines, max.)

#### Pattern/step No. display

Displays the pattern/step No. in the Program mode.

In the FIX mode, "F" is displayed at the PTN field and "- - -" is displayed at the STEP field.

"- - -" at the STEP field goes out during control execution (RUN) in the FIX mode.

#### Output (OUT) display

The control output value (OUT or Posi) is displayed by a numerical value and a bar graph as a percentage (%).

#### Program monitor display

Displays the program status monitor.

#### Remaining step time display

Displays the remaining step time during program operation.

#### Pattern graph display

Displays the pattern (step) graph during program operation.

#### Screen title display

Displays the screen group title in the respective screen group top screen.

#### Setup parameter display

Parameters can be selected and displayed by front key operation.

## ④ Key switches

	Displays the basic screen.
	Changes the screen group. Or, returns to the screen group top screen.
	Switches the parameter display screen in a screen group.
	Selects the parameter to set up or change. The parameter to be changed is indicated by the cursor (▶).
	Moves the digit in set numerical values.
	Decrements parameters and numerical values during setup. When it is under the Manual mode, close output is set to on.
	Increments parameters and numerical values during setup. When it is under the Manual mode, open output is set to on.
	Registers data or parameter numerical values.
	At a reset, increments the start step No. in the basic screen. ( ENT must be pressed to register.)
	At a reset, increments the start pattern No. in the basic screen. ( ENT must be pressed to register.)

The following key combination operations are available in screens from 0-1 to 0-6.

	Hold (HLD) operation
	Advance (ADV) operation

## ⑤ LED indicators

### Status lamps

RUN	green	Lights during control is being executed. Blinks during program start delay time (PRG.Wait).
HLD	green	Lights when the program is paused in Program mode. Blinks when the pause has caused by an input error in Program mode or in Fix mode.
MAN	green	Blinks when control output is set to manual operation (MAN).
FIX	green	Lights in FIX mode.
EV1	orange	Lights during EV1 action.
EV2	orange	Lights during EV2 action.
EV3	orange	Lights during EV3 action.
DO1	orange	Lights during DO1 action.
DO2	orange	Lights during DO2 action.
DO3	orange	Lights during DO3 action.
DO4	orange	Lights during DO4 action.
DO5	orange	Lights during DO5 action.
EXT	green	Lights when start pattern No. selection (PTN2bit, PTN3bit, PTN4bit, PTN5bit) are set to DI5 to DI8.
COM	green	Lights during communication (COM) mode.

AT	green	Blinks during execution of auto tuning, and lights during autotuning standby.
OPEN	green	Lights when open output is ON, and goes out when it is OFF.
CLOSE	green	Lights when close output is ON, and goes out when close it is OFF.

## Error Messages

Code	Cause	
$E-r0\bar{n}$	ROM error	The error codes on the left are displayed on the PV display. These indicate that all outputs turn OFF or become 0%. If any of the messages are displayed, repair or replacement is required. Immediately turn the power OFF, and contact your dealer.
$E-rA\bar{n}$	RAM error	
$E-EEP$	EEPROM error	
$E-Rd1$	Input 1 A/D error	
$E-SPc$	Hardware error	
$Sc\_LL$	The PV value exceeded the measuring range lower limit (-10%FS).	When a PV input-related abnormality is detected during execution of control on this device, the error codes on the left are displayed on the PV display. Check input or the heater lead. If the input or the heater lead is not in error and there is another probable cause, contact your dealer.
$Sc\_HH$	The PV value exceeded the measuring range higher limit (+110%FS), RTD-A burnout, or thermocouple burnout.	
$b\ -\ -\ -$	One or two RTD-B burnout, or all leads of the RTDs burnout. Action of this device in this case is PV moving excessively towards the upper limit.	
$CJ\_LL$	Reference junction compensation (-20°C) is at the lower limit. (thermocouple input)	
$CJ\_HH$	Reference junction compensation (+80°C) is at the higher limit. (thermocouple input)	
ERROR	Feedback potentiometer error	When a feedback is installed, and a burnout of feedback resistor R2 is detected, the message is displayed "Posi" field on LCD screen.

## LCD Flow Chart

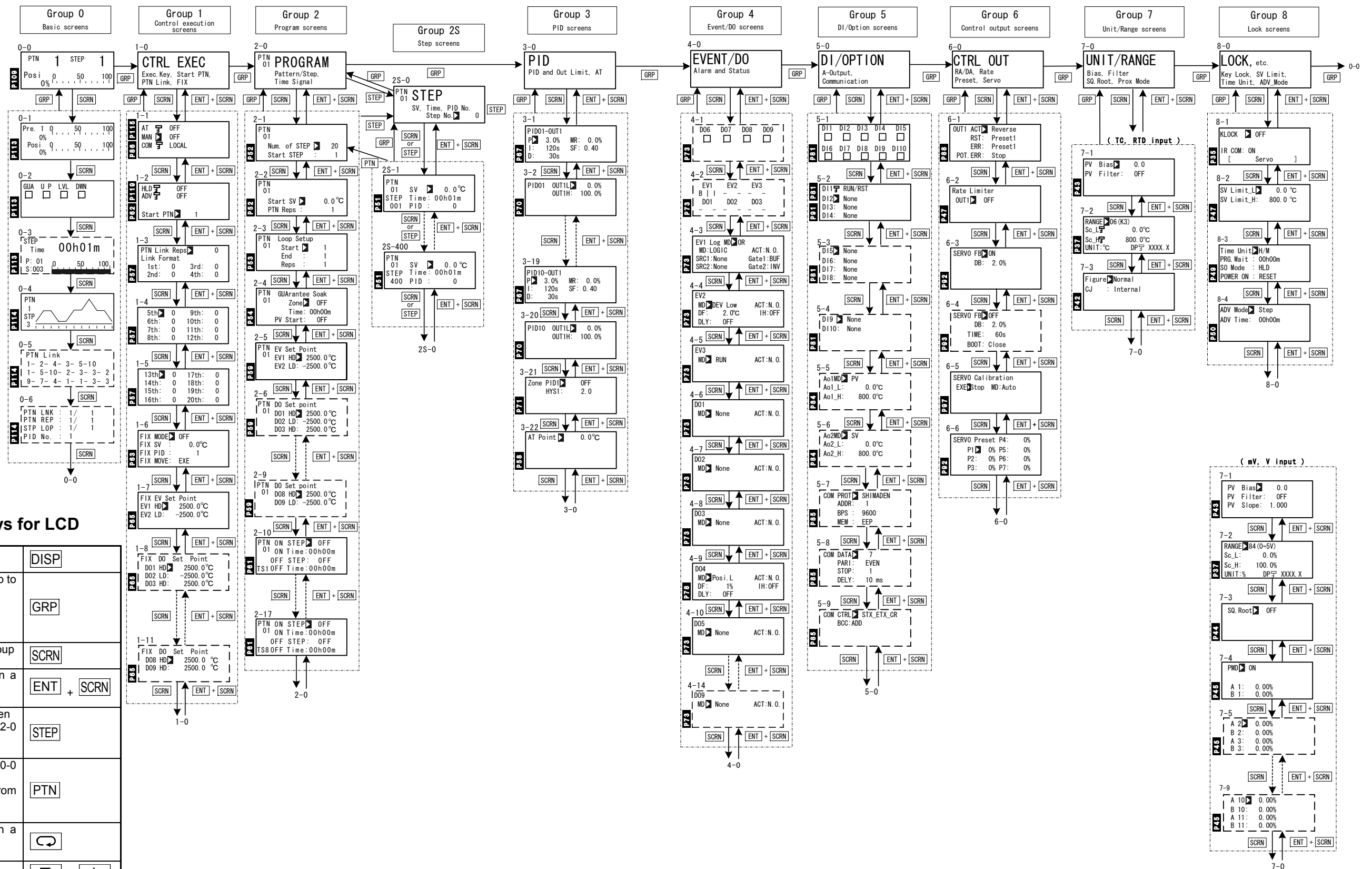

## Frequently-used Keys for LCD

Move to 0-0 Screen (Example : 2-5→0-0)	<b>DISP</b>
Move from a 0 screen of a group to another (Example : 0-0→1-0→2-0)	<b>GRP</b>
Move to the group's 0 screen (Example : 2-4→2-0)	<b>GRP</b>
Move to the next screen in a group (Example : 2-0→2-1→2-2)	<b>SCRN</b>
Move to the previous screen in a group (Example : 2-2→2-1→2-0)	<b>ENT + SCRN</b>
Modify the Step No. at 0-0 Screen Move to the step screens from 2-0 Screen (Example : 2-0→2S-0)	<b>STEP</b>
Modify the Pattern No. at 0-0 Screen Move to Program screens from Step screens (Example : 2S-1→2-1)	<b>PTN</b>
Move to the next parameter in a screen (Example : AT→MAN at 1-1)	<b>↻</b>
Modify a value for a parameter (Example : P at 3-1)	<b>▼</b> or <b>▲</b>
Move from digit to digit for a value	<b>◀</b>
Register a modified value	<b>ENT</b>

**Standard screen** Screens that are always displayed

**Non-standard screen** Screens that are displayed depending on options/setup values.

Refer to the **P. xx** (page) on the Instruction Manual in CD-ROM.