

**Thank you for choosing a NIVELCO instrument.
We are sure that you will be satisfied with it throughout its use!**

PILOTREK

W-100 Ex
NON-CONTACT MICROWAVE
LEVEL TRANSMITTER

SAFETY MANUAL
(1st edition)

CONTROL DRAWING NO.:
wes1404a0600s



(XP-IS) Class I Div 1 Groups C & D T6, IP67
(NI) Class I Div 2 Groups C & D T6, IP67

NIVELCO

Manufacturer:
NIVELCO Process Control Co.
H-1043 Budapest, Dugonics u. 11.
Phone: (36-1) 889-0100 ■ Fax: (36-1) 889-0200
E-mail: sales@nivelco.com ■ www.nivelco.com

1. INTRODUCTION

Read this manual carefully before installing the device in hazardous locations! In case of any questions or doubt with the proper installation contact the Manufacturer.

The PiloTREK W-100 non-contact microwave level transmitters provide the most advanced, new generation measurement technique of the industrial process automation field in potentially explosive atmospheres (hazardous area). PiloTREK is an ideal solution of high precision level transmitting of liquids, slurries, dollops, emulsions and other chemicals with relative dielectric constant above 1.9. The level transmitter induces few nanosecond length microwave impulses in the antenna and a part of the energy of the emitted signals reflects back from the measurement surface depending on the measured media. The time of flight of the reflected signal is measured and processed by the electronics, and then this is converted to distance, level or volume proportional data.

For further information on the operation and programming of the device please refer to the following document:

- **PILOTREK W-100** two-wire non-contact microwave compact level transmitter
User's and Programming Manual (wes1404a0600p)

2. SPECIAL CONDITIONS FOR SAFE USE

- To prevent ignition, the cover of the terminal compartment may not be opened while the electrical circuits are alive or if explosive atmosphere is present. To block accidental opening of the threaded cover, the securing screw must always be tightened when the device is located in hazardous location.
- Aluminium housing of the unit should be connected to the equipotential (grounding) system. For field connections, use cable rated 20 °C greater than Maximum Ambient Temperature and seal all threaded entries within 18 inches of the enclosure with suitably rated sealing components.
- The device may not be set up and installed, unless a qualified NPT ½" threaded cable entry or suitably rated and qualified closing plug is fixed to the place of the plastic closing cap with proper sealing. The metal plug may only be removed if suitably rated cable glands or conduit entries are used.
- To ensure watertight integrity, the covers must be fully tightened to the base and all conduit connections must be properly tightened and sealed.
- The enclosure contains aluminum and is considered a potential risk of ignition by impact or friction. Care must be taken during installation to prevent impact or friction effects.
- The units are not to be used or installed in ketone atmospheres.
- The risk of electrostatic discharge shall be minimized at installation, especially under certain extreme circumstances plastic parts of the antenna may generate an ignition-capable level of electrostatic charges, therefore:
 - The equipment shall not be installed in a location where the external conditions are conducive to the build-up of electrostatic charges on such surfaces.
 - Medium to measure must be electrically conductive and with specific resistance not exceeding the value of 10⁴ Ωm even on the most unfavorable places and under the most unfavorable conditions.
 - Speed as well as way of filling and emptying should be chosen according to the medium.
 - Additionally, the equipment shall only be cleaned with a damp cloth.
- Regarding information on the dimensions of flameproof joints, please contact the Manufacturer.
- Installations in the US shall comply with the relevant requirements of the National Electrical Code® (ANSI/NFPA-70 (NEC®)). Installations in Canada shall comply with the relevant requirements of the Canadian Electrical Code (CSA C22.1).
- For installation in vessels or processes with Maximum Process Temperature above +60 °C make sure that the ambient temperature at the wall of the transmitter enclosure (due to heat convection and radiation) does not exceed the limits given in Section 3 "TEMPERATURE CLASSES AND TEMPERATURE LIMITS".

3. TEMPERATURE CLASSES AND TEMPERATURE LIMITS

MAXIMUM ALLOWED AMBIENT TEMPERATURES OVER MEDIUM TEMPERATURES:

TEMPERATURE CODE (TC)	PROCESS TEMPERATURE (PT) MAX	MAXIMUM ALLOWED AMBIENT TEMPERATURE AT THE ENCLOSURE	MAXIMUM RESULTING SURFACE TEMPERATURE	MODEL VARIANT RESTRICTION
T6 (through T1)	-30 °C...+100 °C ⁽¹⁾	+60 °C (140 °F)	+76 °C	-
T6 (through T1)	-30 °C...+180 °C ⁽¹⁾	+60 °C (140 °F)	+76 °C	For medium temperatures above +100 °C use High Temperature transmitters WHS-1□□□□ or WJS-1□□□□

⁽¹⁾ For technological safety, the process temperature shall always be chosen in accordance with the autoignition temperature of the measured medium.

4. APPLIED STANDARDS

TYPE		WQS-1□□-A	WQS-1□□-B
Marking	US	(XP-IS) Class I Div 1 Gas Groups C & D T6	(NI) Class I Div 2 Gas Groups C & D T6
	Canada	(XP-IS) Class I Div 1 Gas Groups C & D T6	(NI) Class I Div 2 Gas Groups C & D T6
Suitable for hazardous locations		Class I Division 1 Groups C or D Class I Division 2 Groups C or D	Class I Division 2 Groups C or D
Applied standards	US	FM Class 3600 (Edt. 2011), FM Class 3615 (Edt. 2006), FM Class 3610 (Edt. 2015), FM Class 3810 (Edt. 2005), ANSI/IEC 60529 (Edt. 2004)	FM Class 3600 (Edt. 2011), FM Class 3611 (Edt. 2016), FM Class 3810 (Edt. 2005), ANSI/IEC 60529 (Edt. 2004)
	Canada	C22.2 No. 0.4 (Edt. 2013), C22.2 No. 0.5 (Edt. 2016), C22.2 No. 30 (Edt. 2016), C22.2 No. 61010-1 (Edt. 2012), CSA-C22.2 No. 60529 (Edt. 2016), CAN/CSA C22.2 No. 60079-0 (Edt. 2015), CAN/CSA-C22.2 No. 60079-11 (Edt. 2014)	C22.2 No. 0.4 (Edt. 2013), C22.2 No. 0.5 (Edt. 2016), C22.2 No. 213 (Edt. 2016), C22.2 No. 61010-1 (Edt. 2012), CSA-C22.2 No. 60529 (Edt. 2016)
Electrical connection		NPT ½" conduit entry; plug-in type terminal blocks for 0.75 to 1.5 mm ² (16 to 18 AWG) wire cross section	

5. ORDER CODES

PILOTREK W S - 1 -

TYPE	CODE
2-wire transmitter	E
2-wire transmitter + display	G
High temperature transmitter	H
High temperature transmitter + display	J

ANTENNA / DIAMETER	CODE
Parabolic DN150 / Flange	1
Parabolic DN250 / Flange	2
Horn DN40 / 1½"	4
Horn DN50 / 2"	5
Horn DN80 / Flange	8
Horn DN100 / Flange	9

PROCESS CONNECTION	CODE
BSP thread	0
NPT thread	N
Flange DN 80 PN25 (1.4571 / 316Ti)	2
Flange DN 100 PN25 (1.4571 / 316Ti)	3
Flange DN 125 PN25 (1.4571 / 316Ti)	4
Flange DN 150 PN25 (1.4571 / 316Ti)	5
Flange 3" RF 150 psi (1.4571 / 316Ti)	A
Flange 4" RF 150 psi (1.4571 / 316Ti)	B
Flange 5" RF 150 psi (1.4571 / 316Ti)	C
Flange 6" RF 150 psi (1.4571 / 316Ti)	D
Flange JIS 10K80A (1.4571 / 316Ti)	J
Flange JIS 10K100A (1.4571 / 316Ti)	K
Flange JIS 10K125A (1.4571 / 316Ti)	L
Flange JIS 10K150A (1.4571 / 316Ti)	M

OUTPUT / HAZ. RATING	CODE
4...20 mA + HART / XP-IS Class I Div 1	A
4...20 mA + HART / NI Class I Div 2	B

6. INSTALLATION

1. Electronics compartment (incl. optional LCD display)
2. Terminal connection compartment with plug-in terminals (see Sections 7. and 8. for wiring details)
3. NPT ½" conduit or cable entry
4. Equipotential bonding conductor
5. Tank
6. Equipotential bonding conductor
7. Potential equalization network

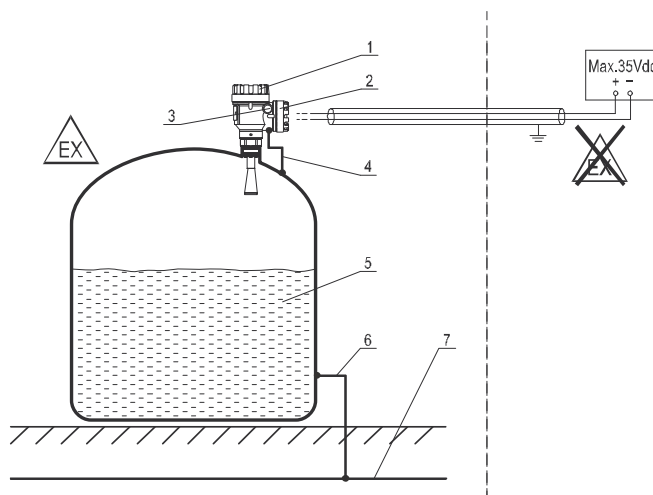

7. ELECTRICAL CONNECTIONS (WIRING) AND LIMITS FOR (NI) Class I Div 2 RATED DEVICES

The side compartment (2) of the dual compartment constructions contains the terminals for connecting the device into a two-wire current loop or HART multidrop circuit.

Please note that the terminals "+" and "-" are connected through a non-resetting fuse and thermal cutoff with the connectors "3" and "4" of the main electronics. The device is protected against reverse polarity. In case of severe overvoltage, overcurrent or high ambient temperature, the fuse or the thermal cutoff located on the back of the connector board goes out permanently. **These components may only be replaced by the manufacturer!** Nevertheless, it is ensured that under normal usage within the specified input and environmental parameters, the components do not pose any limitation to the proper working of the transmitter.

Electrical data: $C_i \leq 16\text{nF}$ $L_i \leq 0.2\text{mH}$ $I_i \leq 22\text{mA}$ $U_i \leq 35\text{V d.c}$

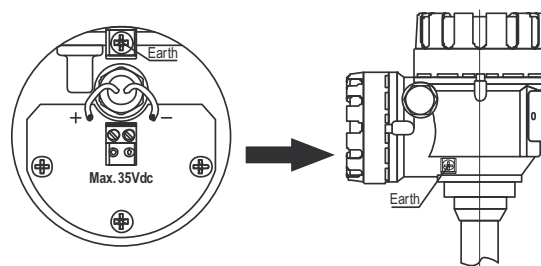

8. ELECTRICAL CONNECTIONS (WIRING) AND MAXIMAL INPUT VOLTAGE FOR (XP-IS) Class I Div 1 RATED DEVICES

The side compartment (2) of the dual compartment constructions contains the terminals for connecting the device into a two-wire current loop or HART multidrop circuit.

Please note that the terminals "+" and "-" are connected through a built-in galvanic isolating and approved intrinsic safe barrier unit, including several non-resetting protection circuits with the connectors "3" and "4" of the main electronics. The device is protected against reverse polarity. In case of severe overvoltage or overcurrent, the protection elements may permanently go out to protect the circuits located in the electronics compartment (1). Although the cover of the electronics compartment (1) may be opened during operation, it is absolutely required to keep the terminal connection compartment (2) tightly closed when the device is being powered or explosive atmosphere may be present. **The repair of the equipment or replacement of any components or modules of the transmitter may impair the intrinsic safety and is therefore only permitted to be carried out by the manufacturer!**

Maximal allowed input voltage: $U_{\text{max}} = 35\text{V d.c}$ $U_{\text{m}} = 250\text{V}$

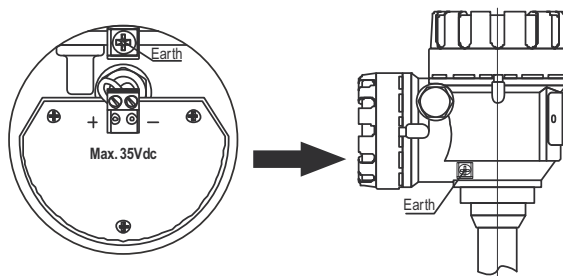

wes1404a0600s_01

May 2017.

NIVELCO reserves the right to change technical data without notice.