

IN-R

Large Display Tachometer Indicator.



Installation Guide.

IN-R Installation Guide Index.

SECTION 1. - Description and Ordering Information.	Page 3
SECTION 2. - Specifications.	Page 3
SECTION 3. - Casing and display.	Page 4
3.1 - Case dimensions.	Page 4
3.2 - Front panel.	Page 4
3.3 - Display shortcuts.	Page 4
3.4 - Display brightness.	Page 4
SECTION 4. - Wiring.	Page 5
4.1 - Pinouts.	Page 5
4.2 - Position the input jumpers.	Page 5
4.3 - Wire the analogue input module.	Page 6
4.4 - Wire the relays.	Page 7
4.5 - Wire the analogue output.	Page 7
4.6 - Wire the function pins.	Page 7
4.7 - Wire the power supply.	Page 7
4.8 - Power up your indicator.	Page 7
SECTION 5. - Setup & Calibration.	Page 8
5.1 - Enter PIN.	Page 8
5.2 - Input setup.	Page 8
5.3 - Averaging.	Page 8
5.4 - Analogue output setup.	Page 8
5.5 - Edit calibration PIN.	Page 9
SECTION 6. - Set-point Setup.	Page 9
6.1 - Enter PIN.	Page 9
6.2 - Edit set-points.	Page 9
6.3 - Edit set-point PIN.	Page 10
SECTION 7. - Set-point Direct Access.	Page 10
SECTION 8. - Reset PIN Numbers.	Page 10

SECTION 1. – Description.

The IN-R is a technically advanced but cost effective microprocessor-based controller designed specifically for use in tachometer applications. Options for up to four relay outputs make it ideal for stand-alone control or as a PLC interface.

Intuitive scrolling text menus (activated from the front panel), guide you step by step through the setup and calibration process, and the large 4-digit display ensures that the figures can be easily read from a distance.



Ordering Information.

ITEM	CODE		DESCRIPTION
SERIES	IN-R-		Large display Tachometer Indicator
RELAY OUTPUTS	N-		None
	R2-		2x 5A relay outputs
	R4-		4x 5A relay outputs
ANALOGUE OUTPUT	N-		None
	A-		1 x 4~20mA / 0~10V Analogue Output
POWER SUPPLY	HV		85~265Vac / 95~370Vdc
	LV		15~48Vac / 10~72Vdc

Ordering Example: **IN-R-R4-A-LV** Large Display Tachometer Indicator; 4x 5A relay outputs, 1x 4~20mA / 0~10V Analogue output, 15~48Vac / 10~72Vdc Power Supply.

SECTION 2. – Specifications.

Easy setup	Scrolling text prompts for intuitive, easy setup.
Security	Calibration and set-point functions have independent security code access (direct access to set-point activation values is independently configurable).
Input signal	0~24Vdc or 0~30Vac. Selectable sensor type: Logic (Open collector (NPN/PNP), Namur, TTL) or Magnetic pickup (Tacho).
Pulses per revolution	User selectable from 1 to 9999 pulses per revolution.
Measurement range	1~99990RPM (1ppr sensor) to 0.1~99990RPM (10ppr sensor).
Display resolution	0.1RPM, 1RPM or 10RPM (displayed as RPM/1000).
Input noise filtering	Selectable low pass filter options: Off, 200Hz, 2kHz or 20kHz.
Power supply	HV: 85~265Vac / 95~370Vdc or LV: 15~48Vac / 10~72Vdc.
Excitation	24Vdc (50mA max).
Sampling rate	Nominally 3Hz (low RPM mode=Off).
Accuracy	0.1RPM.
Temperature drift	Typically 30ppm/°C.
Calibration	Factory calibrated.
Relay outputs	2 or 4 programmable relay outputs with hysteresis and delay on make.
Analogue Output	Isolated 16-bit 4~20mA / 0~10V output (fully scaleable). Window programmable over any range within the full-scale range of the indicator.
LED indicators	4x LED annunciators for alarms and relay status indication.
Case	48mm x 96mm x 119.5mm (H x W x D) / 45.5mm x 92.5mm panel cutout.

Product Liability. This information describes our products. It does not constitute guaranteed properties and is not intended to affirm the suitability of a product for a particular application. Due to ongoing research and development, designs, specifications, and documentation are subject to change without notification. Regrettably, omissions and exceptions cannot be completely ruled out. No liability will be accepted for errors, omissions or amendments to this specification. Technical data are always specified by their average values and are based on Standard Calibration Units at 25C, unless otherwise specified. Each product is subject to the 'Conditions of Sale'.

Warning: These products are not designed for use in, and should not be used for patient connected applications. In any critical installation an independent fail-safe back-up system must always be implemented.

SECTION 3. – Casing & display.

3.1 – Case dimensions:

Dimensions:

48 x 96 x 119.5mm (H x W x D).

Panel cutout:

45.5 x 92.5mm (H x W).

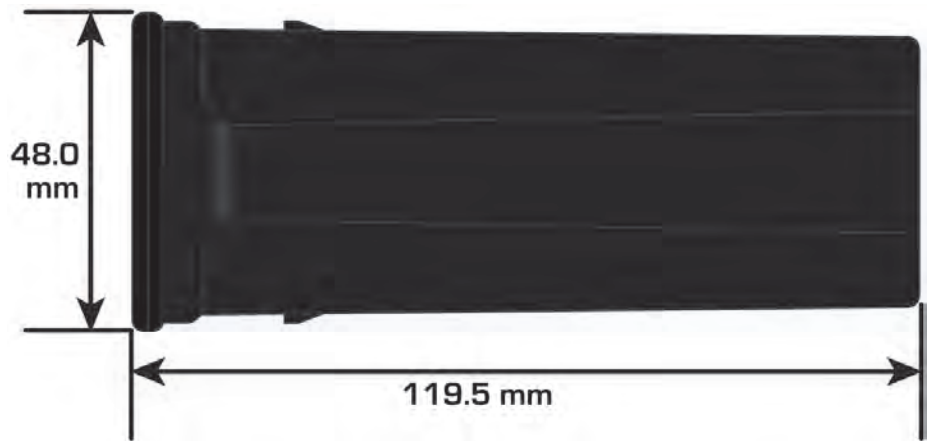

3.2 – Front panel:

SP(X) The set-point LED's are used to indicate active set-points.

- F1** This button is used to access the **Input Setup & Calibration** menu. See section 5.
- P** This button is typically used to save your settings and advance to the next step in the setup process.
- ▲** This button is typically used to scroll through options or increase values in the setup menu. Pressing this button from the main display will allow you to view/reset the peak value (see 3.3).
- ▼** This button is typically used to scroll through options or decrease values in the setup menu. Pressing this button from the main display will allow you to view/reset the valley value (see 3.3).
- F2** This button is used to access the **Set-point Setup** menu (see section 6) and the **Set-point Open Access** menu (see section 7).

3.3 – Display shortcuts:

- ▲** Used to view/reset the **PEAK** value. Press **P** to return to the main display.
 - Press the **▲** button once from the main display. **PEAK** appears and toggles with the maximum measured RPM value (since the instrument was turned on or reset).
 - To reset **PEAK**, press both the **▲** and **▼** buttons together now.
- ▼** Used to view/reset the **VALLEY** value. Press **P** to return to the main display.
 - Press the **▼** button once from the main display. **VALLEY** appears and toggles with the minimum measured RPM value (since the instrument was turned on or reset).
 - To reset **VALLEY**, press both the **▲** and **▼** buttons together now.

3.4 – Display brightness:

- A Press the **P** and **▲** buttons together from the operational display. **BRI** appears and toggles with the current brightness setting.
- B Use the **▲** and **▼** buttons to adjust the brightness of the LED backlight as required, and then press **P**. The display returns to normal operating mode.

SECTION 4. – Wiring.

4.1 – Pinouts:

- A – Relay output (Refer to 4.4)
- B – Analogue output (Refer to 4.5)
- C – Analogue input (Refer to 4.2-3)
- D – Function pins (Refer to 4.6)
- E – Power supply (Refer to 4.7)

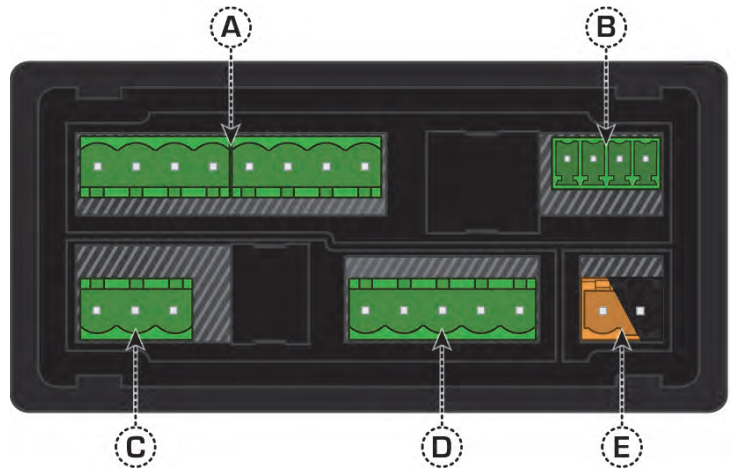

4.2 – Position the input jumpers:

Before you can begin wiring, the IF11 input module must be removed from the meter case so that the jumpers can be positioned for your input type. Remove the plastic backing plate from the rear of the meter by inserting a screwdriver into the indents circled on the image. Once the backing plate has been removed, gently slide the input module from the case (see Section 4.1C to identify the input module).



The IF11 input module has four jumpers, some of which may need to be repositioned to suit your application. Please consult the table below for more information on positioning the jumpers to suit your requirements. **Jumper B should always be set to COUNTER.**

When you have finished, slide the input module back into the case and replace the plastic backing plate.

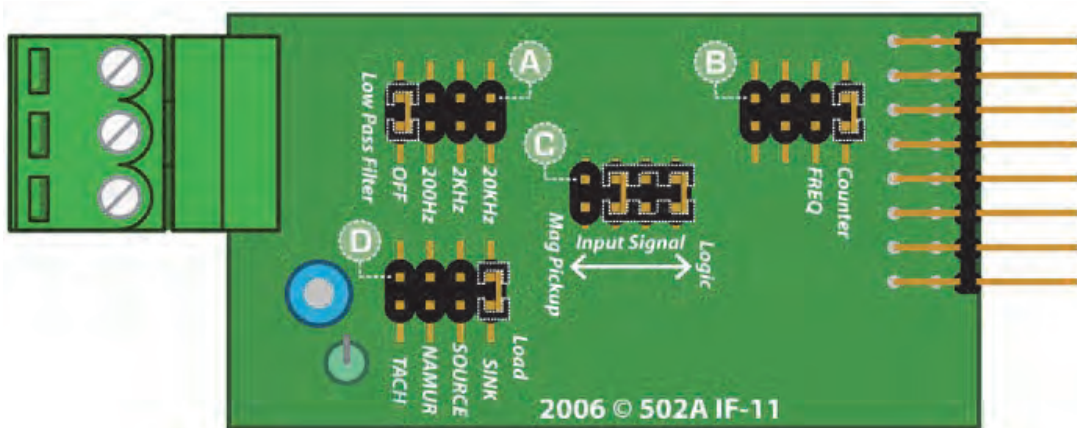

JUMPER POSITIONING:

A - Input noise filtering	OFF: Ideal for high-speed counting.	C - Input signal	Logic: NPN, PNP, namur, TTL & Pushbuttons, Mag Pickup: Tacho.
	2kHz: Suitable for a noisy signal.		Sink: NPN, TTL & pushbuttons.
B - Mode	200Hz: Ideal for mechanical contacts.	D - Load	Source: PNP.
	20kHz: Suitable for a noisy signal.		Namur: Namur.
	Counter: ALWAYS use this setting.		Tach: Tacho.
	Frequency: Not used for IN-R.		

Example showing a Jumper In & Jumper Out:

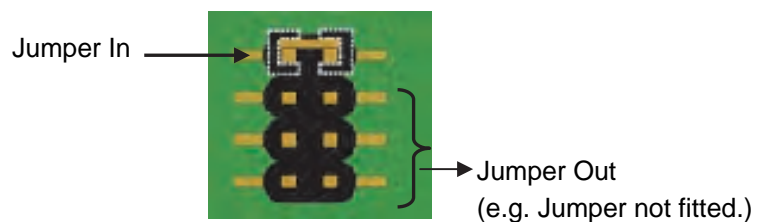

4.3 – Wire your IF11 analogue input module:

Refer to 4.1C

Make sure that you have completed Section 4.2 before you begin wiring your input module. Once you have adjusted your jumper settings as needed and replaced the plastic backing plate, wire your input module as shown in the appropriate diagram as follows:

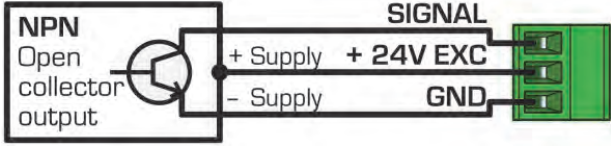
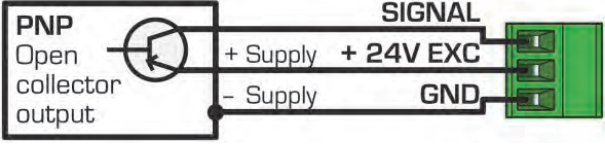
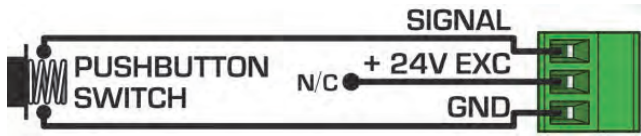
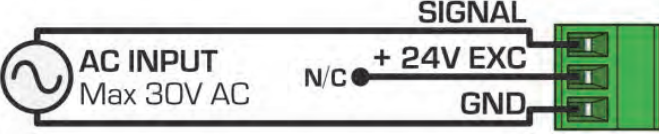
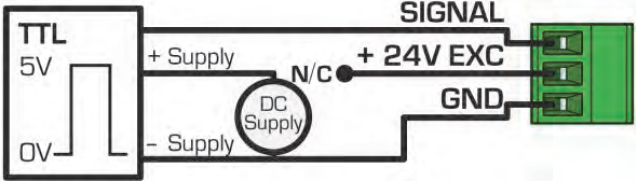
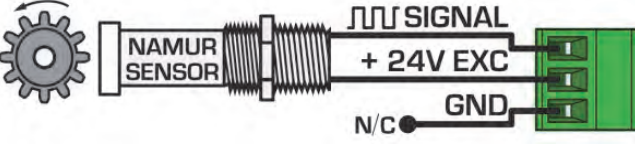
<p>NPN open collector output with proximity switch: Active sensor signal: 0V. Inactive sensor signal: +24V.</p> 	<p>Jumper</p> <p>A Input noise filtering: See table in section 4.2</p> <p>B Mode: Counter.</p> <p>C Input Signal: Logic.</p> <p>D Load: Sink.</p>
<p>PNP open collector output with proximity switch: Active sensor signal: +24V. Inactive sensor signal: 0V</p> 	<p>Jumper</p> <p>A Input noise filtering: See table in section 4.2</p> <p>B Mode: Counter.</p> <p>C Input Signal: Logic.</p> <p>D Load: Source.</p>
<p>Pushbutton switch: Open signal: +24V. Closed signal: 0V.</p> 	<p>Jumper</p> <p>A Input noise filtering: 200Hz.</p> <p>B Mode: Counter.</p> <p>C Input Signal: Logic.</p> <p>D Load: Sink.</p>
<p>Tacho generator sensor:</p> 	<p>Jumper</p> <p>A Input noise filtering: See table in section 4.2</p> <p>B Mode: Counter.</p> <p>C Input Signal: Mag Pickup.</p> <p>D Load: Tach.</p>
<p>TTL input: In this example the TTL logic has a separate +5V power supply.</p> 	<p>Jumper</p> <p>A Input noise filtering: See table in section 4.2</p> <p>B Mode: Counter.</p> <p>C Input Signal: Logic.</p> <p>D Load: Sink.</p>
<p>Namur sensor: Active sensor signal: 0.3~1.0mA. Inactive sensor signal: 1.7~3.0mA.</p> 	<p>Jumper</p> <p>A Input noise filtering: See table in section 4.2</p> <p>B Mode: Counter.</p> <p>C Input Signal: Logic.</p> <p>D Load: Namur.</p>

4.4 – Wire your relays (if fitted):

Refer to 4.1A

Wire your relays as per the diagram. IN-R relays can be programmed to operate within the total span range of the controller. If you do not have any relays fitted, step 4.4 is skipped.

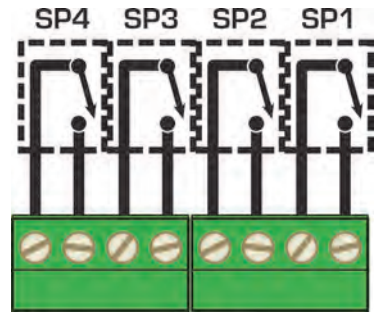

4.5 – Wire your analogue output (if fitted):

Refer to 4.1B

If your IN-R has an analogue output fitted, wire it as shown. If you do not have an analogue output, step 4.5 is skipped.

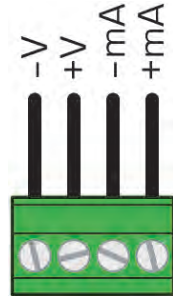

4.6 – Wire your function pins (if required):

Refer to 4.1D

Connect external switches (as shown) to enable a function to be executed when its switch is activated.

- Valley** Clears the valley reading.
- Hold** Holds the display value.
- Test** Resets the meter.
- Peak** Clears the peak reading.

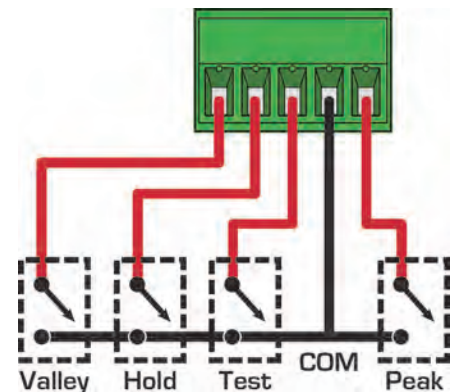

4.7 – Wire the power supply:

Determine whether your indicator is configured for low or high voltage power supply. Make sure to check the label on the unit against the colour of the power connector:

Orange = High voltage HV (85~265Vac / 95~370Vdc).

Black = Low voltage LV (15~48Vac / 10~72Vdc).

<p>Wire your indicator to your power supply as per the appropriate diagram. Refer to 4.1E</p> <div style="border: 1px solid black; padding: 5px; margin-top: 10px;"> <p style="color: red; text-align: center;">Remember to switch your power supply off before you begin wiring, and NEVER connect your low voltage indicator to mains power.</p> </div>	<p>High Voltage (HV) 85~265Vac / 95~370Vdc</p> <p>+DC / live AC - DC / neutral AC</p>	<p>Low Voltage (LV) 15~48Vac / 10~72Vdc</p> <p>+DC / live AC - DC / neutral AC</p>
--	---	--

4.8 – Power up your indicator:

Once you have completed the wiring process it is safe to switch on your power supply. Ensure that your display is functioning before you proceed.

SECTION 5. – Setup & calibration.

You will have the opportunity to change your PIN number at the end of this section (5.5). If you have forgotten your PIN number, see Section 8.

Enter the setup and calibration mode by pressing **F1**.

Note:

To SKIP or ENTER values - Push



To SELECT a menu input - Push



5.1- a. --- **ENTER CAL PIN NUMBER** and **0** scroll across.

Use the **▲** and **▼** buttons to enter your security code (factory default = 1). Then press **P**.

If the correct PIN number is entered then the setup is started at (5.2).

If an incorrect PIN number is entered, --- **INCORRECT PIN NUMBER - ACCESS DENIED** scrolls across the display and it returns to the normal operating mode.

5.2- a. --- **INPUT SETUP** and **SKIP** scroll across.

Press **P** to skip to (5.3), or the **▲** button to **ENTR** (enter) input setup. Then press **P**.

b. --- **ENTER PULSES PER REVOLUTION** scrolls across. Using the **▲** and **▼** buttons, enter the number of pulses per revolution of your sensor: from **1** to **9999**. Then press **P**.

c. --- **DISPLAY RESOLUTION** scrolls across.

Using the **▲** and **▼** buttons, select: **0.1**, **1**, or **10** RPM. Then press **P**.

The maximum RPM value that the IN-R can measure is determined by the number of pulses per revolution that the sensor outputs. 0.1 resolution = max 999.9 RPM. 1 resolution = max 9999 RPM (cannot be used for sensors that output more than 3932 ppr). 10 resolution = max 99990 RPM (cannot be used for sensors that output ore than 393 ppr—note that in this mode the RPM value is displayed as RPM/1000, with the decimal point at 2 places (i.e. XX.XX x 1000).

d. --- **LOW RPM MODE** scrolls across.

Using the **▲** and **▼** buttons, set the low RPM mode: either **OFF** or **ON**. Then press **P**.

Select ON if your operating range is between 1 and 150 RPM and you are using a sensor with less than 10 ppr. This will allow very low measurements (down to 1 RPM). Note that LOW RPM MODE slows down the response time of the display as the RPM value drops below 5 RPM for 1 ppr sensors. In this instance a quick speed change to zero can cause the display to freeze on a higher RPM value for up to 100 seconds.

e. --- **DISPLAY ROUNDING** scrolls across.

Using the **▲** and **▼** buttons, select the display rounding: either **NONE**, **2**, **5** or **10**. Then press **P**.

Rounding is in display counts and is not influenced by decimal point position, i.e. If the input signal is 5.3, the display will show 5.3 (NONE), 5.4 (2), 5.5 (5) or 5.0 (10).

5.3- a. --- **AVERAGING PARAMETERS** and **SKIP** scroll across.

Press **P** to skip to (5.4), or the **▲** button to **ENTR** (enter) averaging parameters setup. Then press **P**.

Your indicator has input signal averaging, optimizing stable measurement. If the change in input exceeds the averaging window value it will not average, ensuring fast response when there are large differences between readings.

b. --- **AVE SAMPLES** and the currently selected averaging scroll across. Using the **▲** and **▼** buttons, alter the signal averaging. Then press **P**.

Increasing the number of samples will stabilise measurement, but it will also slow down response rates.

c. --- **AVE WINDOW** and the currently selected averaging window value scroll across.

Using the **▲** and **▼** buttons, alter the signal averaging window. Then press **P**.

If your input signal contains large noise spikes, you can increase the size of the averaging window to ensure that these pulses are still averaged. However, increasing the size of the averaging window too far will reduce the ability of the controller to respond quickly to real changes in input signal. Setting AVE WINDOW to 0 will give continuous averaging as per the selected averaging samples.

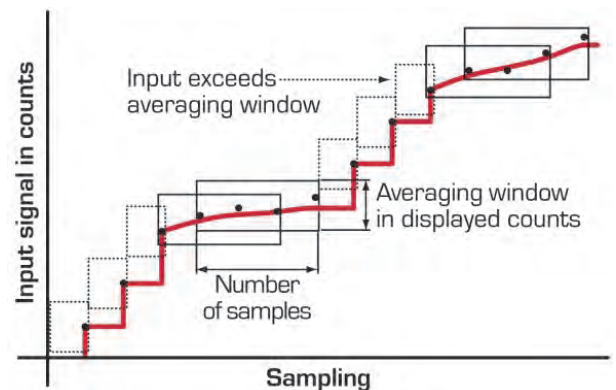

5.4- a. --- **ANALOG OUTPUT SETUP** scrolls across the display and toggles with **SKIP**.

Press **P** to skip to (5.5), or connect a mA or volt meter across the analogue output connector (see 4.5) and then press the **▲** button and then **P** to **ENTR** (enter) setup.

b. --- **LOW SCALE VALUE FOR ANALOG OUTPUT** scrolls across the display and toggles with the current selection. Use the **▲** and **▼** buttons to enter your cal low position, and then press **P**.

This sets the display value for cal low (as in 5.4b).

- c. --- **HIGH SCALE VALUE FOR ANALOG OUTPUT** scrolls across the display and toggles with the current selection. Use the ▲ and ▼ buttons to enter your cal high position, and then press **P**.
This sets the display value for cal high (as in 5.4c).
 - d. --- **CALIBRATE ANALOG OUTPUT** scrolls across the display and toggles with **SKIP**. Press **P** to skip to (5.4e), or connect a mA or volt meter across the analogue output connector (see 4.5) and then press the ▲ button and then **P** to **ENTR** (enter) setup.
 - e. --- **CAL LOW ANALOG OUTPUT** scrolls across the display and toggles with a calibration number. Using the ▲ and ▼ buttons, calibrate your low analogue output as required. Then press **P**.
The display value is shown in internal units (mA or V).
 - f. --- **CAL HIGH ANALOG OUTPUT** scrolls across the display and toggles with a calibration number. Using the ▲ and ▼ buttons, calibrate your high analogue output as required. Then press **P**.
The display value is shown in internal units (mA or V).
- 5.5- a. --- **EDIT CAL PIN NUMBER** and **SKIP** scroll across. Press **P** to skip and return to the operational display, or the ▲ button to **ENTR** (enter). Then press **P**.
- b. --- **ENTER NEW CAL PIN NUMBER** and your current PIN number (factory default = 1) scroll across. Using the ▲ and ▼ buttons, enter your new calibration entry PIN number. Do not forget this number! Then press **P** to **EXIT** and return to the operational display.

SECTION 6. – Set-point setup.

This section is only available if you have relay outputs installed. If your model is an indicator only, please skip Section 6. You will have the opportunity to change your PIN number at the end of this section (6.3). If you have forgotten your PIN number, see Section 8.

Note:
To SKIP or ENTER values - Push **P**
To SELECT a menu input - Push ▲

Enter the setpoint setup mode by pressing and holding the **F2** button for 3 seconds.

- 6.1- a. --- **ENTER SP PIN NUMBER** and **0** scroll across. Using the ▲ and ▼ buttons, enter your security code number (factory default = 1). Then press **P**.
If the correct PIN is entered then the setup is started at (6.2).
If an incorrect PIN is entered, --- **INCORRECT PIN NUMBER – ACCESS DENIED** scrolls across the display and it returns to the normal operating mode.
- 6.2- a. --- **EDIT SETPOINT** and **SKIP** scroll across. Press **P** to skip to (6.3), or use the ▲ and ▼ buttons to select a set-point to edit, and then press **P**.
- b. --- **SP VALUE** and the last set-point value entered scroll across. Using the ▲ and ▼ buttons, adjust the selected set-point value. Then press **P**.
- c. --- **SP ACTIVATION** scrolls across. Using the ▲ and ▼ buttons, select the relay activation to operate **ABVE** (above) or **BLW** (below) the set-point value. Then press **P**.
ABVE: Relay turns on above the set-point value and off below it. **BLW:** Relay turns on below the set-point value and off above it.
- d. --- **HYSTERESIS VALUE** and the last selected hysteresis value scroll across. Using the ▲ and ▼ buttons, select the hysteresis value if required. Then press **P**.
*The **HYSTERESIS VALUE** is the separation value from the set-point value for set-point reactivation.*
*If **ABVE** is selected for **SP ACTIVATION** (6.2c), the **HYSTERESIS VALUE** determines how far the input must fall below the **SP VALUE** (6.2b) to deactivate the set-point.*
*If **BLW** is selected for **SP ACTIVATION** (6.2c), the **HYSTERESIS VALUE** determines how far the input must rise above the **SP VALUE** (6.2b) to deactivate the set-point.*

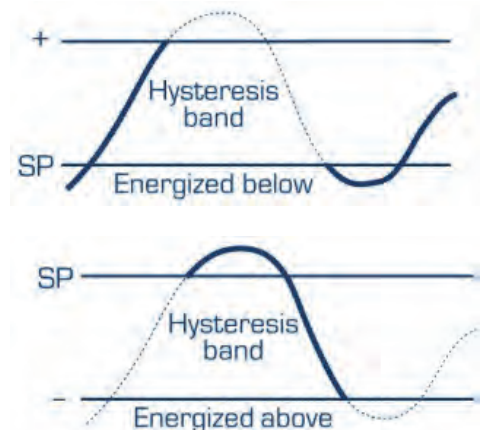

- e. **--- MAKE DELAY** and the last selected make delay value scroll across.
Using the **▲** and **▼** buttons, select the set-point delay value if required. Then press **P**.
This value is displayed in seconds with a 0.1 second resolution.
 - f. **--- OPEN ACCESS TO SP VALUE** and the last selected direct access setting scroll across.
Using the **▲** and **▼** buttons, select **YES** or **NO** to enable or disable the direct access option for this set-point. (When enabled, the direct access option allows the set-point value to be edited directly after pressing the **F2** button, without needing to enter a PIN number). Then press **P**.
 - g. **--- EDIT SETPOINT** and **SKIP** scroll across.
To edit another set-point, use the **▲** and **▼** buttons to select the new set-point to edit. Then press **P** and proceed from (6.2b). If you do not wish to edit another set-point, press **P** to proceed to (6.3).
- 6.3- a. **--- EDIT SP PIN NUMBER** and **SKIP** scroll across.
Press **P** to skip and return to the operational display, or the **▲** button to **ENTR** (enter). Then press **P**.
- b. **--- ENTER NEW SP PIN NUMBER** and your current PIN number (factory default = 1) scroll across.
Using the **▲** and **▼** buttons, enter your new calibration entry PIN number. Do not forget this number! Then press **P** to **EXIT** and return to the operational display.

SECTION 7. – Set-point direct access.

Open access is configured individually for each set-point (see 6.2f).

If none of the set-points have their direct access option enabled then this feature will be disabled and the **F2** button will not respond to a short button press.

- a. Begin by pressing the **F2** button for less than 3 seconds (i.e. a short press). The set-point name will toggle on the display with the current set-point value. Using the **▲** and **▼** buttons, adjust the selected value. Then press **P** to accept the new set-point value.
- b. If any other set-points have the direct access option enabled then the same process is repeated for the next set-point. Pressing **P** for the last enabled set-point will exit direct access mode and return to the operational display.

SECTION 8. – Reset PIN numbers.

If you have forgotten either of your PIN numbers, follow the procedure below to reset both the calibration and setpoint entry PIN's to their factory default of 1.

- a. Press the **▲**, **▼** and **P** buttons at the same time.
(This key combination can be difficult to execute and you may need several attempts to get it right.)
- b. When successful, a factory identification text will scroll across the display, followed by:
- ALL PIN NUMBERS RESET TO 1.
- c. Reset the default PIN numbers if required by following the instructions in 5.5 (for the input setup and calibration menu) and 6.3 (for the set-point setup menu), entering '1' whenever you are prompted for your current PIN.

Intech INSTRUMENTS LTD
www.intech.co.nz
Christchurch Ph: +64 3 343 0646
Auckland Ph: 09 827 1930
Email: sales@intech.co.nz