

JUMO ecoTRANS Lf 03

Transmitter/Switching Device for Conductivity
Type 202732



Operating Manual



20273200T90Z001K000

V3.00/EN/00429233

1	Notes	5
2	Identifying the device version	6
2.1	Type designation	6
3	Installation	7
4	Electrical connection	7
5	Commissioning	12
5.1	Fundamentals of conductivity measurement	12
5.2	Applying the supply voltage	13
6	Setting / altering the device functions	14
6.1	Actual-value display	14
6.2	Operation	15
6.3	Function of keys	15
6.4	Level selection	17
6.5	The operator level (USER)	18
6.6	The administrator level (ADMIN)	19
6.7	The enabling level (RIGHT)	20
6.8	The calibration level (CALIB)	21
7	Setting ranges	22
8	Configurable parameters	24
8.1	Inputs	25
8.1.1	Measurement input for conductivity (submenu CON)	25
8.1.2	Measurement input for temperature (submenu TEMP)	29
8.2	Relay / open-collector	31
8.2.1	Logic output 1 (submenu BIN.1)	31
8.2.2	Logic output 2 - option (submenu BIN.2)	34
8.3	Analog outputs	37
8.3.1	Conductivity (submenu CO.OUT)	37
8.3.2	Temperature (submenu TE.OUT)	39
9	Calibration	42
9.1	General	42
9.1.1	Measurements in highly-purified water	43
9.2	Activating the calibration mode	44

9.3	Selecting the calibration procedure	45
9.4	Calibrating the temperature coefficient using automatic temperature measurement	46
9.5	Calibrating the temperature coefficient using manual temperature entry	49
9.6	Calibrating the relative cell constant	51
10	Analog output	54
10.1	Response of the output signal during calibration	54
10.2	Response of the output signal to a fault condition	54
10.3	Output signal in fault condition	55
10.4	Response of the output signal on leaving the scaling range	56
10.5	Manual operation of the analog output	56
11	Relay output / open-collector	57
11.1	Response of the relay	57
11.2	Manual operation of the relay outputs	57
11.3	Response of the relay during calibration	59
11.4	Pulse function of the relay output	59
11.5	Response of the relay in fault condition	59
11.6	Fault detection	60
12	The USP contact (for high-purity water)	62
12.1	USP pre-alarm	63
13	Display and LED messages	64
13.1	Operating states of the JUMO ecoTrans Lf 03	64
13.2	Underrange	64
13.3	Overrange	64
13.4	Probe break	64
13.5	Short circuit	65
13.6	Initialization of dependent parameters	65
13.7	Calibration timer has run down	65
14	Operation via setup interface	66
14.1	Operation through Setup	67
15	Technical data	68
16	Environment / waste disposal	72
17	China RoHS	74

1 Notes



To protect the device from electrostatic discharge, users must discharge themselves electrostatically before touching the device !

All necessary settings are described in this Operating Manual. However, if any difficulties should still arise during start-up, please do not carry out any manipulations on the unit. You could endanger your rights under the device warranty! Please contact the nearest subsidiary or the head office in such a case.

Please read this operating manual before starting up the device. Keep the manual in a place which is accessible to all users at all times. Please assist us to improve this operating manual, where necessary.

2 Identifying the device version

The nameplate with the order code is glued to the side of the housing. The supply voltage must correspond to the voltage given on the nameplate.

2.1 Type designation

(1) Basic type

202732 JUMO ecoTRANS Lf 03,
Microprocessor transmitter / switching device for
conductivity (freely programmable ranges)

(2) Output I (conductivity / resistivity)

888 analog signal output, freely programmable

(3) Output II (temperature)

888 analog signal output, freely programmable

(4) Output III (switching)

101 1 x relay, changeover contact

177 2 x open-collector

(5) Extra codes

000 none

024 delivery includes PC setup software

999 customer-specific programming

	(1)	(2)	(3)	(4)	(5)				
Order code	<input type="text" value="202732"/>	/	<input type="text" value="888"/>	-	<input type="text" value="888"/>	-	<input type="text"/>	/	<input type="text"/>

Order example	<input type="text" value="202732"/>	/	<input type="text" value="888"/>	-	<input type="text" value="888"/>	-	<input type="text" value="177"/>	/	<input type="text" value="024"/>
----------------------	-------------------------------------	---	----------------------------------	---	----------------------------------	---	----------------------------------	---	----------------------------------

3 Installation

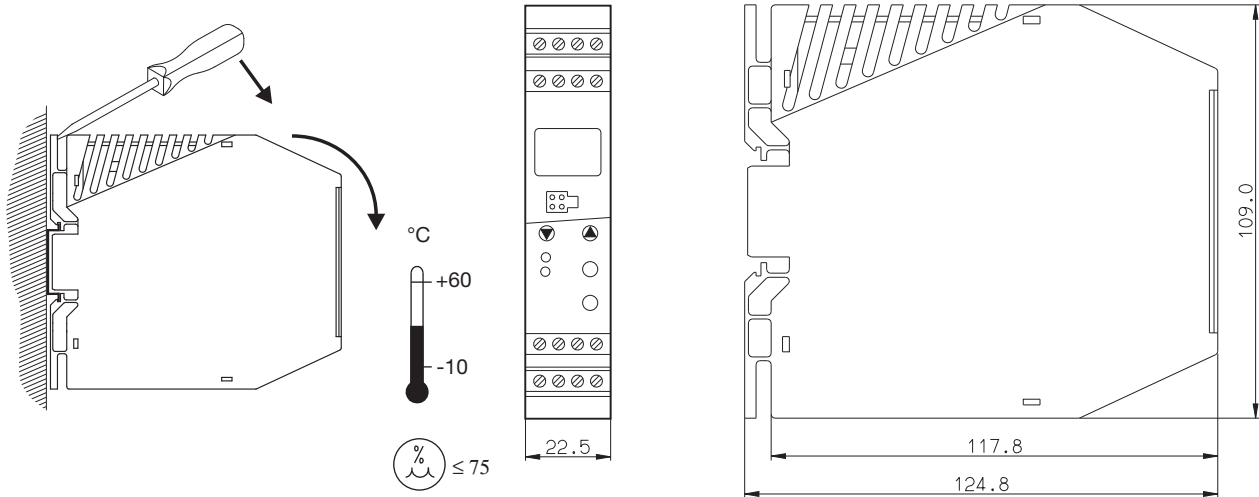

4 Electrical connection

The choice of cable, the installation, the fusing and the electrical connection must conform to the requirements of VDE 0100 “Regulations on the Installation of Power Circuits with Nominal Voltages below 1000 V” or the appropriate local regulations.

- The electrical connection must only be carried out by qualified personnel.
- Electromagnetic compatibility conforms to the standards and regulations cited in the technical data.
- For operation with SELF or PELF circuits.
- The device is **not** suitable for use in areas with an explosion hazard (Ex areas).

Apart from faulty installation, incorrect settings on the device may also affect the proper functioning of the subsequent process or lead to damage. Safety devices should always be provided that are independent of the device (such as overpressure valves or temperature monitors/limiters) and only capable of adjustment by specialist personnel. Please observe the relevant safety regulations for such matters.

-
- ❑ The load circuit must be fused for the maximum relay current, in order to prevent the output relay contacts becoming welded in the event of a short circuit.
 - ❑ The electrical energy must be supplied to the machine via a 125 mA medium time lag fuse or equivalent protection through a separate branch.
 - ❑ Do not connect any additional loads to the screw terminals for the supply of the device.
 - ❑ Any electrical connection other than that specified in the connection diagram may result in the destruction of the device.
 - ❑ Run input, output and supply cables separately and not parallel to one another.
 - ❑ Probe leads must be implemented as twisted and shielded, uninterrupted cables (do **not** run them via terminal blocks or similar).
 - ❑ Supply fluctuations are only permissible within the specified tolerances (see Data Sheet 20.2732).
 - ❑ The device must only be assembled or disassembled in the de-energized state or when the cables are not connected.

Terminal assignment

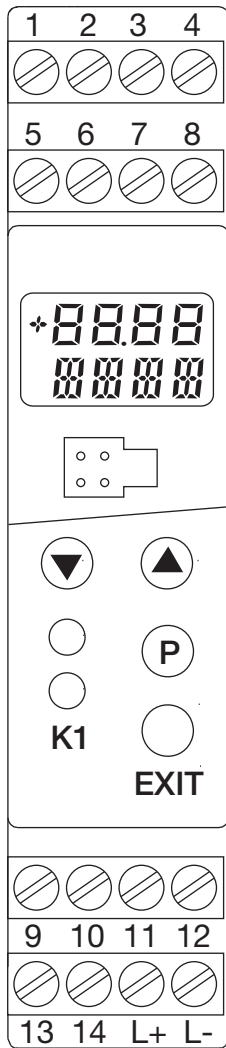

Outputs	Terminals	Symbol
I Analog signal output for conductivity (electrically isolated)	5 + 6 -	
II Analog signal output for temperature (electrically isolated)	7 + 8 -	

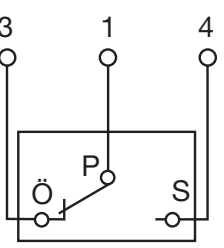
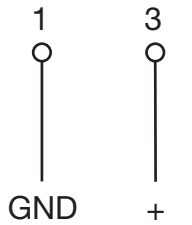
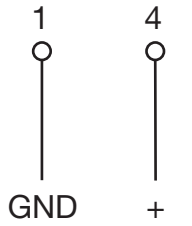
III Relay	1	common	
	3	n.c. (break)	
	4	n.o. (make)	
Open-collector output 1 (electrically isolated)	1	GND	
	3	+	
Open-collector output 2 (electrically isolated)	1	GND	
	4	+	

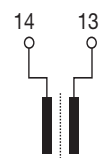
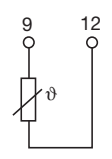
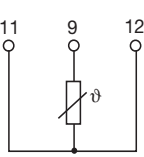
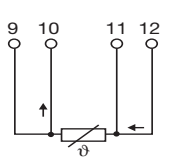
Measurement inputs		Terminals	Symbol
Conductivity cell		14 outer electrode, on coaxial cells	
		13 inner electrode, on coaxial cells	
Resistance thermometer in 2-wire circuit		9 temperature sensor	
		12	
Resistance thermometer in 3-wire circuit		9 temperature sensor	
		11	
		12	
Resistance thermometer in 4-wire circuit		9 temperature sensor	
		10	
		11	
		12	

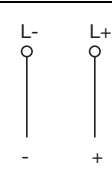
Supply		Terminals	Symbol
Supply voltage (with reverse-polarity protection) for operation with SELF or PELF circuits. DC 20 to 30 V Power consumption ≤ 3 W.		L- L +	

Connection of the conductivity cell

	Conductivity cell (JUMO types)			JUMO ecoTRANS Lf 03
	Plug-in head	Attached cable	M12 connector	
Outer electrode		white	1	14
Inner electrode	2	brown	2	13
Temperature compensation	1	yellow	3	9*
	3	green	4	12*

* type of connection: 2-wire

5 Commissioning

5.1 Fundamentals of conductivity measurement

Principle of measurement

Electrolytic conductivity measuring cells basically consist of two metal plates arranged opposite each other which are immersed in the solution to be measured. The conductivity of the solution is determined through the measuring voltage and the resulting measuring current.

The current between the metal plates depends on their geometry (distance and area). The **cell constant** describes this dependence. Subject to manufacturing tolerances, or because of dirt or wear, the real cell constant of a measuring cell often deviates from its nominal value. This deviation is reflected by the **relative cell constant** that is adjustable on the conductivity transmitter.

The conductivity of a solution depends on temperature (i.e. the conductivity of a solution increases with rising temperature). The **temperature coefficient** of the solution describes the dependence of conductivity and temperature. Since conductivity is not always measured at the reference temperature, automatic temperature compensation has been integrated. The transmitter uses the temperature coefficient to calculate the conductivity that would be present at the reference temperature from the current conductivity and the current temperature, and then display this value. This process is called temperature compensation. Modern transmitters offer various variants to carry out this temperature compensation:

- Linear compensation (constant temperature coefficient).
This type of compensation can be used with normal water with an acceptable level of accuracy. The temperature coefficient used is then about 2,2 %/K.
- Natural water (DIN EN27888 or ISO 7888 as the case may be).
In this case, a so-called non-linear temperature compensation is used. According to the above standard, the corresponding type of compensation can be applied in the case of natural ground water, mountain spring water and surface water.
The conductivity of the water is compensated in the range from

0°C to 36°C.

- Non-linear

Here, the actual graph of the temperature coefficient during a heating-up or cooling-down process is determined by the transmitter.

- ASTM1125-95.

This type of temperature compensation is employed for measurements in very pure water. Here, the extremely non-linear behavior of the temperature dependence is taken into consideration according to the above standard.

The conductivity of the water is compensated in the range from 0°C to 100°C.

5.2 Applying the supply voltage

When the device has been correctly connected, all LCD segments will be shown briefly, immediately after applying the supply voltage.

Note

After initializing the controller, the output signal is 0 V or 0 mA. The logic outputs or relays are in the quiescent state (inactive). After approx. 2 sec, the JUMO ecoTRANS Lf 03 operates according to its configuration.

6 Setting / altering the device functions

Alterations can be carried out in the setup program or from the keys of the JUMO ecoTRANS Lf 03.

6.1 Actual-value display

The actual value is displayed either in the

- static mode or in the
- alternating mode

Static display (default setting)

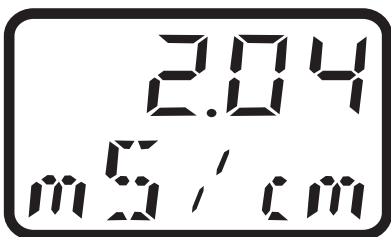

Compensated conductance with current unit

Alternating display (fixed rhythm: approx. 3 seconds)



Compensated conductance with current unit

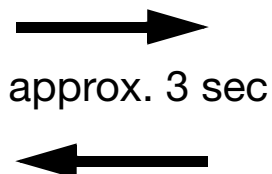

Current temperature with current unit

Change from static display (compensated conductivity only) to alternating display

* Press **(P)** (for less than 2 sec)

Change from alternating display to static display

* Press **(P)** (for less than 2 sec)

6.2 Operation

The operation of the device is arranged on levels.

The access to all levels (exception: operator level) is protected by different codes².

At the **operator level** (USER), all parameters can be viewed or altered in accordance with the user rights¹ (see enabling level).

At the **calibration level** (CALIB), the cell constant and/or temperature coefficient can be calibrated.

At the **enabling level** (RIGHT), the user rights can be defined.

At the **administrator level** (ADMIN), all parameters can be set (configured).

The different codes and the settings at the enabling level make it possible to assign different rights to the user.

¹ In the factory default setting, all parameters are set to READ, which means that all parameters can only be read at the operator level but not altered.

² The codes for the administrator and enabling levels can only be altered through the setup program, see Chapter 14 “Operation via setup interface”, page 66.

6.3 Function of keys



After 60 seconds without operator action (key stroke) the device jumps back to displaying the actual value.

This time-out function is inactive during calibration!

- Use the UP and DOWN keys to select a submenu in the main menu or to scroll forwards or backwards.
- Use the P key to change to the corresponding submenu.
- If you want to alter (edit) a parameter, press the P key.
- If the parameter has been enabled for editing, the value flashes, if the parameter is inhibited, LOCK is displayed.

-
- In order to alter a parameter, it must be enabled at the enabling level (set from “rEAd” to “Edit”).
 - Press the UP or DOWN key to increase or decrease the value.
 - Accept the value by pressing the P key.
 - Use the EXIT key to cancel the entry and change to the next-higher level.

6.4 Level selection

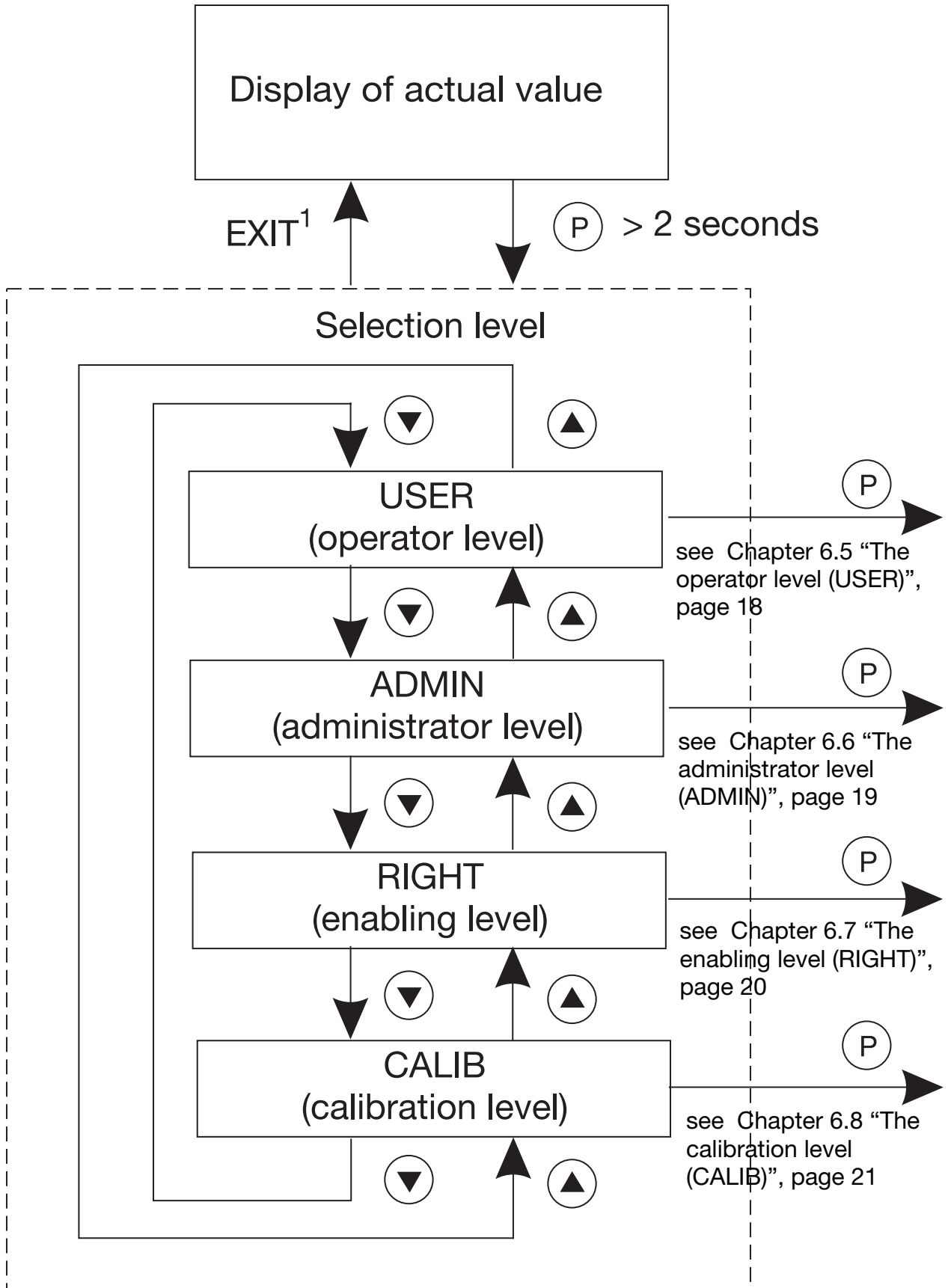

¹ or time-out (automatic return after 60 sec without operator action)

6.5 The operator level (USER)

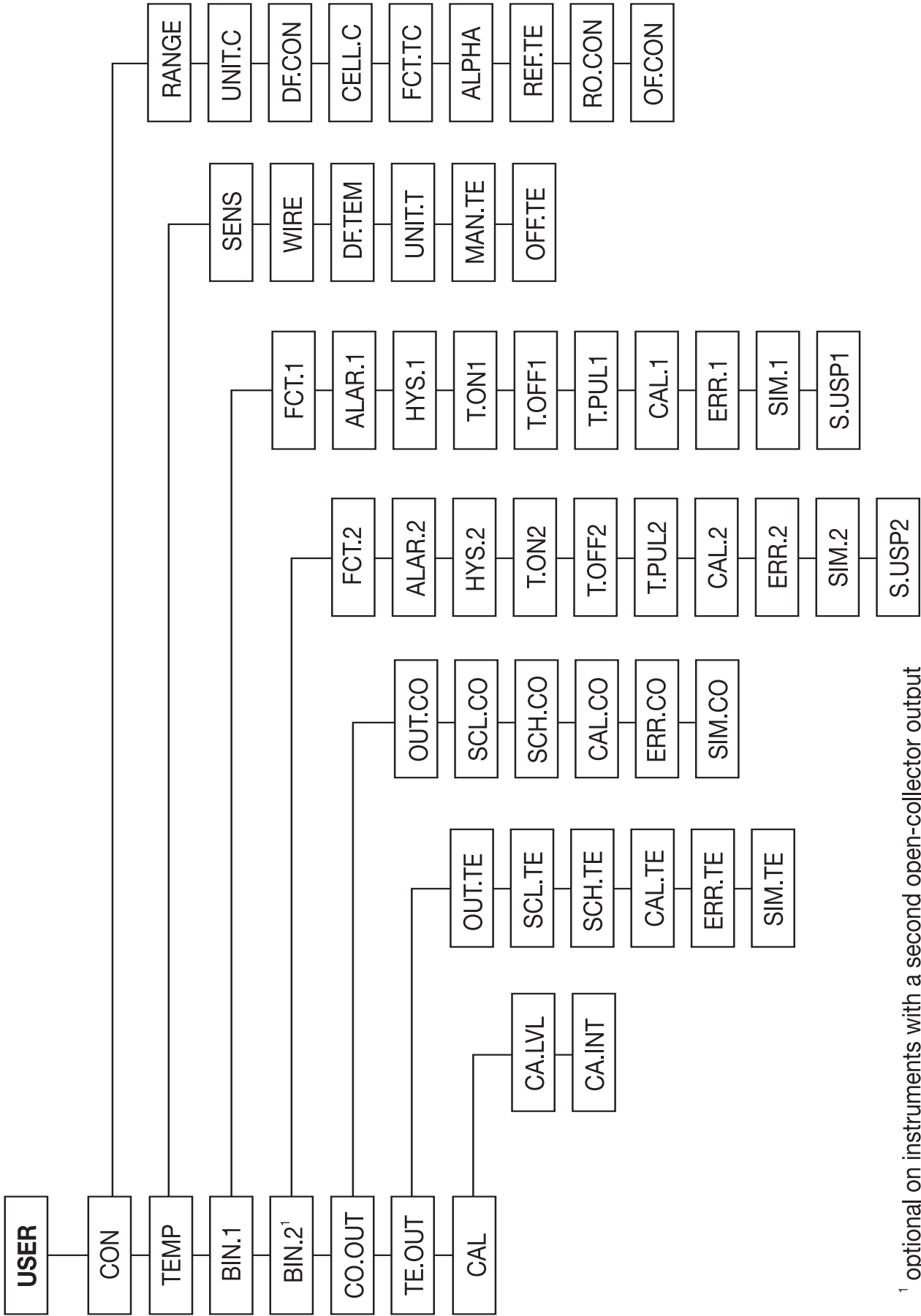

¹ optional on instruments with a second open-collector output

6.6 The administrator level (ADMIN)

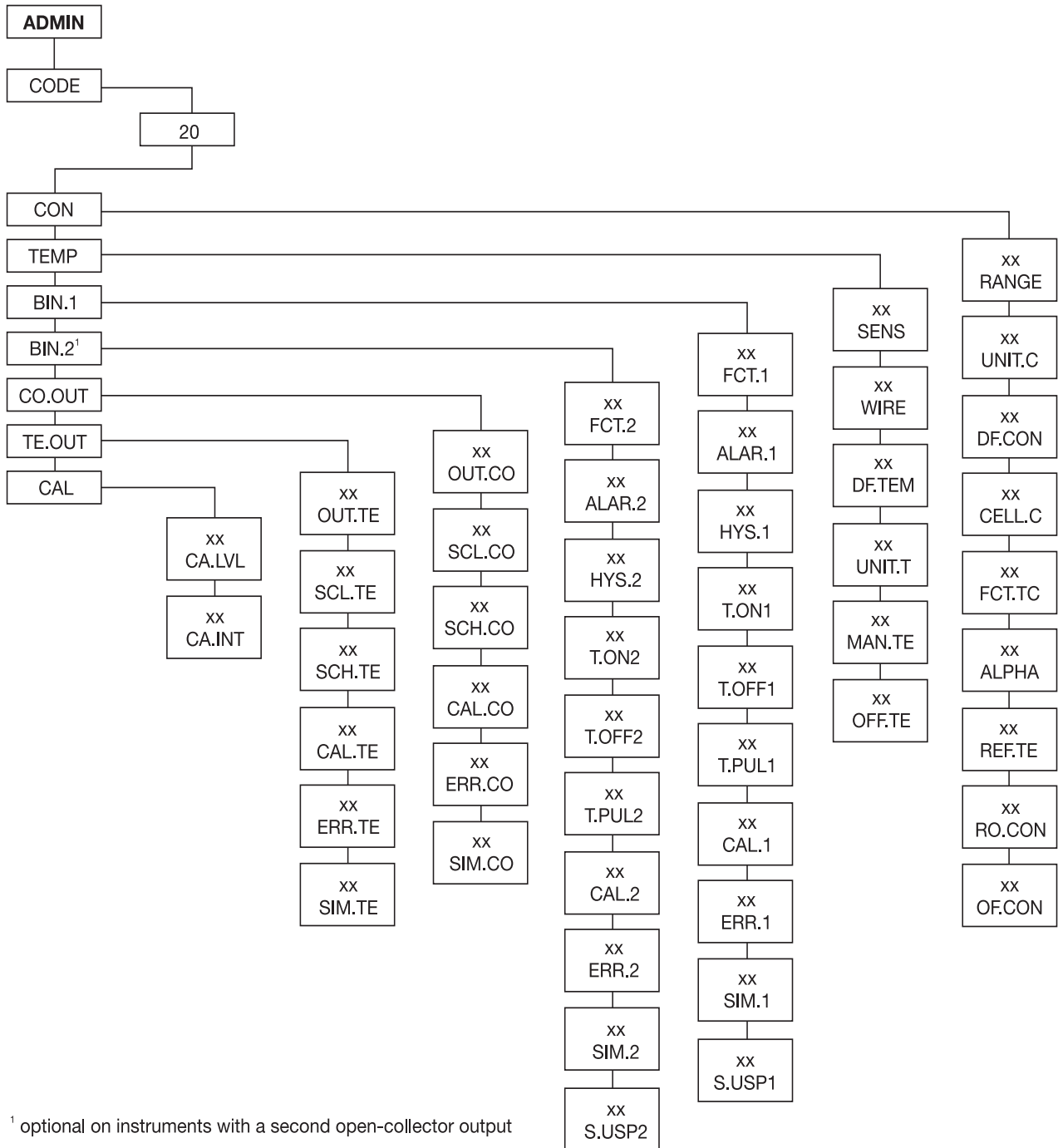

6.7 The enabling level (RIGHT)

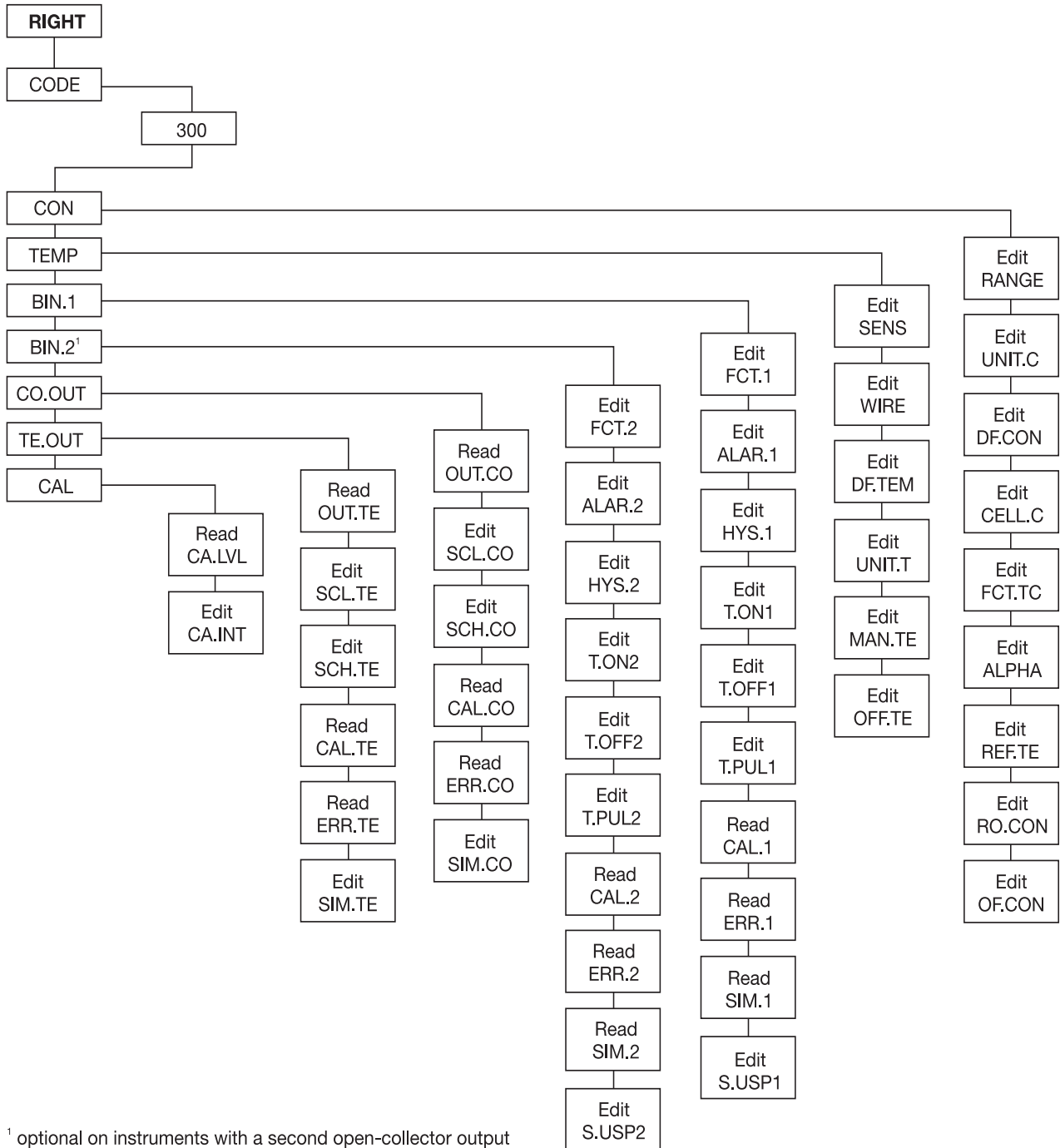

Parameters at the operator level (USER)

Value	is shown	can be altered
EDIT	X	X
READ	X	-

6.8 The calibration level (CALIB)

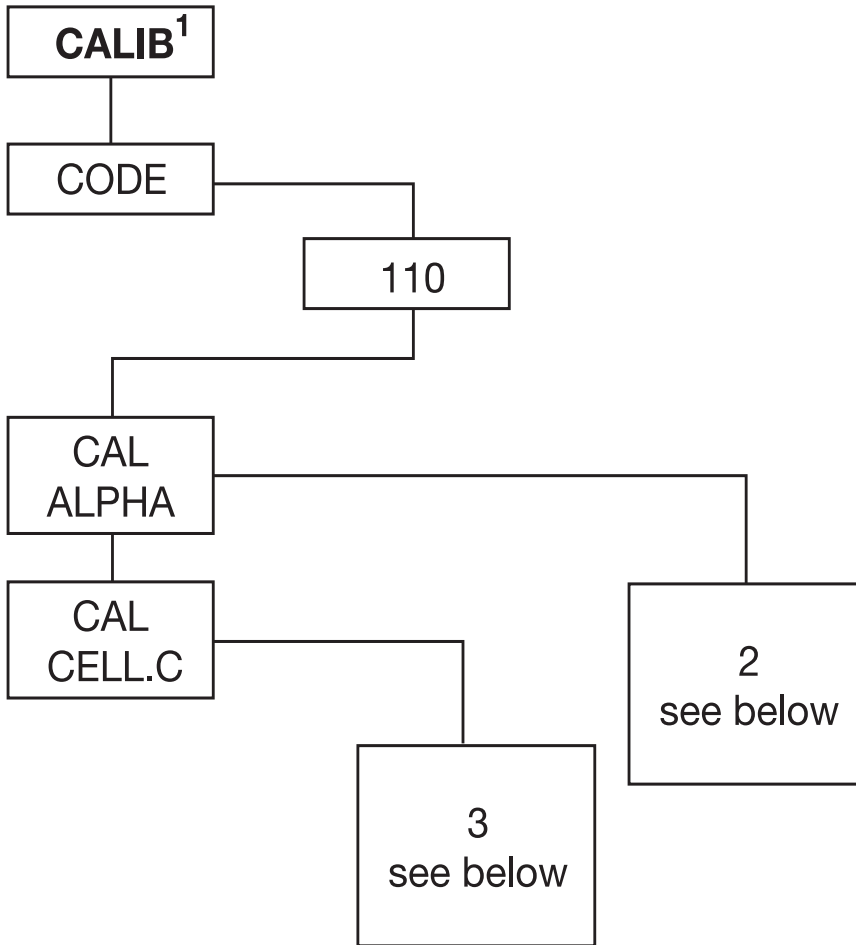

¹ see Chapter 9 “Calibration”, page 42.

² see Chapter 9.4 “Calibrating the temperature coefficient using automatic temperature measurement”, page 46 or Chapter 9.5 “Calibrating the temperature coefficient using manual temperature entry”, page 49.

³ see Chapter 9.6 “Calibrating the relative cell constant”, page 51.



The time-out function is **not** active during calibration!

7 Setting ranges

0 – 1 μS to 0 – 200 mS, depending on the cell constant

Unit		0 = S/cm	1 = mho/cm	
Cell constant	Range			
$0.01^{1/\text{cm}}$	1	0 – 1.000 $\mu\text{S/cm}$	0 – 1.000 $\mu\text{mho/cm}$	1
	2	0 – 2.00 $\mu\text{S/cm}$	0 – 2.00 $\mu\text{mho/cm}$	1
	3	0 – 5.00 $\mu\text{S/cm}$	0 – 5.00 $\mu\text{mho/cm}$	1
	4	0 – 20.00 $\mu\text{S/cm}$	0 – 20.00 $\mu\text{mho/cm}$	2
$0.1^{1/\text{cm}}$	5	0 – 5.00 $\mu\text{S/cm}$	0 – 5.00 $\mu\text{mho/cm}$	1
	6	0 – 20.00 $\mu\text{S/cm}$	0 – 20.00 $\mu\text{mho/cm}$	1
	7	0 – 200.0 $\mu\text{S/cm}$	0 – 200.0 $\mu\text{mho/cm}$	2
	8	0 – 1000 $\mu\text{S/cm}$	0 – 1000 $\mu\text{mho/cm}$	3
$1^{1/\text{cm}}$	9	0 – 500.0 $\mu\text{S/cm}$	0 – 500.0 $\mu\text{mho/cm}$	1
	10	0 – 1000 $\mu\text{S/cm}$	0 – 1000 $\mu\text{mho/cm}$	3
	11	0 – 2.00 mS/cm	0 – 2.00 mmho/cm	2
	12	0 – 10.00 mS/cm	0 – 10.00 mmho/cm	3, 4
	13	0 – 20.00 mS/cm	0 – 20.00 mmho/cm	2
	14	0 – 100.0 mS/cm	0 – 100.0 mmho/cm	3, 4
$3^{1/\text{cm}}$	15	0 – 30.00 mS/cm	0 – 30.00 mmho/cm	3, 4
$10^{1/\text{cm}}$	16	0 – 100.0 mS/cm	0 – 100.0 mmho/cm	3, 4
	17	0 – 200.0 mS/cm	0 – 200.0 mmho/cm	3

The deviations from the characteristic listed below refer to $\mu\text{S/cm}$ or mS/cm

1	deviation from characteristic $\leq 1\%$
2	deviation from characteristic $\leq 1.5\%$
3	deviation from characteristic $\leq 2\%$
4	Above a temperature of $\geq 85^\circ\text{C}$ and a temperature coefficient $T_K > 2.2\%/^\circ\text{C}$, the deviations from the characteristic may be larger.

Unit		2 = kΩ*cm	3 = MΩ*cm	
Cell constant	Range			
0.01 ^{1/cm}	1	1000 – 9999 kΩ*cm	1.00 – 99.99 MΩ*cm	1
	2	500 – 9999 kΩ*cm	0.50 – 50.00 MΩ*cm	1
	3	200 – 9999 kΩ*cm	0.20 – 20.00 MΩ*cm	1
	4	50 – 2500 kΩ*cm	0.05 – 2.50 MΩ*cm	2
0.1 ^{1/cm}	5	200 – 9999 kΩ*cm	0.20 – 20.00 MΩ*cm	1
	6	50 – 2500 kΩ*cm	0.05 – 2.50 MΩ*cm	1
	7	5.0 – 250.0 kΩ*cm		2
	8	1.00 – 50.00 kΩ*cm		3
1 ^{1/cm}	9	2.00 – 99.99 kΩ*cm		1
	10	1.00 – 50.00 kΩ*cm		3
	11	0.50 – 25.00 kΩ*cm		2
	12	0.10 – 5.00 kΩ*cm	--	3, 4
	13	--		2
	14	--		3, 4
3 ^{1/cm}	15	--		3, 4
10 ^{1/cm}	16	--		3, 4
	17	--		3
		not recommended		
--		not possible		

The deviations from the characteristic listed below refer to μS/cm or mS/cm	
1	deviation from characteristic ≤ 1%
2	deviation from characteristic ≤ 1.5%
3	deviation from characteristic ≤ 2%
4	Above a temperature of ≥ 85°C and a temperature coefficient T _K > 2.2%/°C, the deviations from the characteristic may be larger.

8 Configurable parameters



The parameters can be set through the setup program or on the device.

When altering one parameter, it may be necessary to adjust other parameters as well, because some parameters are affected by others.

Example:

When altering the measuring range, the display format, setpoints and other parameters will also be adjusted.

During internal parameter adjustment, the display will show:

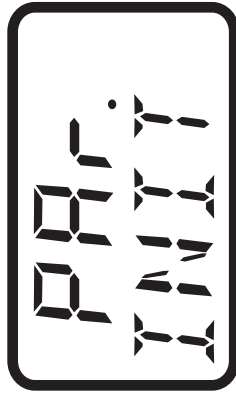

8.1 Inputs

8.1.1 Measurement input for conductivity (submenu CON)

Parameter	Display	Setting range ¹
Measurement ranges with nominal cell constant	RANGE	1 = 0 – 1 $\mu\text{S/cm}$ $K = 0.01 \frac{1}{\text{cm}}$ 2 = 0 – 2 $\mu\text{S/cm}$ $K = 0.01 \frac{1}{\text{cm}}$ 3 = 0 – 5 $\mu\text{S/cm}$ $K = 0.01 \frac{1}{\text{cm}}$ 4 = 0 – 20 $\mu\text{S/cm}$ $K = 0.01 \frac{1}{\text{cm}}$ 5 = 0 – 5 $\mu\text{S/cm}$ $K = 0.1 \frac{1}{\text{cm}}$ 6 = 0 – 20 $\mu\text{S/cm}$ $K = 0.1 \frac{1}{\text{cm}}$ 7 = 0 – 200 $\mu\text{S/cm}$ $K = 0.1 \frac{1}{\text{cm}}$ 8 = 0 – 1000 $\mu\text{S/cm}$ $K = 0.1 \frac{1}{\text{cm}}$ 9 = 0 – 500 $\mu\text{S/cm}$ $K = 1 \frac{1}{\text{cm}}$ 10 = 0 – 1000 $\mu\text{S/cm}$ $K = 1 \frac{1}{\text{cm}}$ 11 = 0 – 2 mS/cm $K = 1 \frac{1}{\text{cm}}$ 12 = 0 – 10 mS/cm $K = 1 \frac{1}{\text{cm}}$ 13 = 0 – 20 mS/cm $K = 1 \frac{1}{\text{cm}}$ 14 = 0 – 100 mS/cm $K = 1 \frac{1}{\text{cm}}$ 15 = 0 – 30 mS/cm $K = 3 \frac{1}{\text{cm}}$ 16 = 0 – 100 mS/cm $K = 10 \frac{1}{\text{cm}}$ 17 = 0 – 200 mS/cm $K = 10 \frac{1}{\text{cm}}$

¹ The default setting is shown **bold**. All other possible ranges, see Chapter 7 “Setting ranges”, page 22

Parameter	Display	Setting range ¹
Dimensional unit of conductivity	UNIT.C	0 = $\mu\text{S/cm}$ or mS/cm 1 = $\mu\text{mho/cm}$ or mmho/cm 2 = $\text{k}\Omega \cdot \text{cm}$ 3 = $\text{M}\Omega \cdot \text{cm}$
Filter constant for conductivity (2nd order filter)	DF.CON	0— 2 —99 seconds
Relative cell constant	CELL.C	20.00— 100 —500.0%

¹ The default setting is shown **bold**.

Parameter	Display	Setting range ¹
Type of temperature compensation	FCT.TC	0 = no compensation 1 = linear compensation 2 = natural water (EN 27 888) 3 = ASTM 1125-95 (neutral contamination) Note If compensation is activated, the USP contact or USP pre-alarm functions are deactivated. See also: Chapter 12 “The USP contact (for high-purity water)”, page 62.
Temperature coefficient of liquid	ALPHA	0 – 2.2 – 5.5%/°C
Reference temperature	REF.TE	10.00 to 25 to 40.00°C

¹ The default setting is shown **bold**

Parameter	Display	Setting range ¹
Lead compensation for conductivity	RO.CON	0.00 — 99.99 Ω Note The effect of long cables for the measuring ranges above approx. 20 mS/cm can be compensated by entering the lead resistance.
Actual-value correction for conductivity (offset)	OF.CON	Setting range and representation of numbers depend on the measuring range. 0.00 mS/cm Note Zero-point errors caused by the system can be compensated.

¹ The default setting is shown **bold**.

8.1.2 Measurement input for temperature (submenu TEMP)

Parameter	Display	Setting range ¹
Probe type	SENS	0 = Manual temperature entry 1 = Pt100 2 = Pt1000 3 = NTC 2 kΩ 4 = KTY-10/11-6 5 = NTC 2.25 kΩ 6 = customer-specific
Connection type of temperature sensor	WIRE	2 = 2-wire 3 = 3-wire 4 = 4-wire
Filter constant temperature (2nd order filter)	DF.TE	0— 2 —99 seconds
Temperature unit	UNIT.T	0 = °C 1 = °F

¹ The default setting is shown **bold**.

Parameter	Display	Setting range ¹
Manual temperature entry	MAN.TE	-10 to 25 to 250.0°C or 14 to 77 to 482°F Note The default setting depends on the selected temperature unit UNIT.T.
Actual-value correction for temperature (offset)	OFF.TE	-20.00 to 0 to 20.00°C or -36 to 0 to 36°F Note The default setting depends on the selected temperature unit UNIT.T.

¹ The default setting is shown **bold**.

8.2 Relay / open-collector

8.2.1 Logic output 1 (submenu BIN.1)

Parameter	Display	Setting range ¹
Switching function Note Alterations of this parameter will affect: - ALAR.1 - HYS.1. When the USP contact or the USP pre-contact is activated, then temperature compensation FCT.TC is deactivated.	FCT.1	0 = no function 1 = MAX contact: conductivity (make, similar to LK7) ² 2 = MIN contact: conductivity (break, similar to LK8) ² 3 = MAX contact: temperature (make, similar to LK7) ² 4 = MIN contact: temperature (break, similar to LK8) ² 5 = USP contact (switching point as per USP <645> see Chapter 12 “The USP contact (for high-purity water)”, page 62) 6 = USP pre-contact (see Chapter 12.1 “USP pre-alarm”, page 63) 7 = calibration timer has run down 8 = fault output

¹ The default setting is shown **bold** / ² see Chapter 11 “Relay output / open-collector”, page 57

Parameter	Display	Setting range ¹
Switching point	ALAR.1	According to measuring range (in configured unit) 2.00 mS/cm
Hysteresis	HYS.1.	According to measuring range (in configured unit) 0.04 mS/cm (2% of range with range 0 – 2 mS/cm) or 5°C or 9°F
Pull-in delay	T.ON1	0– 2 –999 seconds
Drop-out delay	T.OFF1	0– 1 –999 seconds Note The parameter is only active if pulse time T.PUL1 = 0.
Pulse time	T.PUL1	0 –999 seconds, see Chapter 11 “Relay output / open-collector”, page 57
Response of logic output 1 in calibration mode	CAL.1	0 = inactive 1 = active 2 = remains in current state

¹ The default setting is shown **bold**.

Parameter	Display	Setting range ¹
Response to fault	ERR.1	0 = inactive 1 = active 2 = frozen (relay remains unchanged)
Manual mode	SIM.1	OFF = no manual mode 0 = inactive 1 = active
USP pre-contact	S.USP1	0— 20 —100% Note If the USP contact or the USP pre-contact is activated, temperature compensation FCT.TC is deactivated. See also Chapter 12.1 “USP pre-alarm”, page 63.

¹ The default setting is shown **bold**.

8.2.2 Logic output 2 - option (submenu BIN.2)

Parameter	Display	Setting range ¹
<p>Switching function</p> <p>Note Alterations of this parameter will affect:</p> <ul style="list-style-type: none"> - ALAR.2 - HYS.2. <p>When the USP contact or the USP pre-contact is activated, then temperature compensation FCT.TC is deactivated.</p>	<p>FCT.2</p>	<p>0 = no function</p> <p>1 = MAX contact: conductivity (make, similar to LK7)²</p> <p>2 = MIN contact: conductivity (break, similar to LK8)²</p> <p>3 = MAX contact: temperature (make, similar to LK7)²</p> <p>4 = MIN contact: temperature (break, similar to LK8)²</p> <p>5 = USP contact (switching point as per USP <645> see Chapter 12 “The USP contact (for high-purity water)”, page 62)</p> <p>6 = USP pre-contact (see Chapter 12.1 “USP pre-alarm”, page 63)</p> <p>7 = calibration timer has run down</p> <p>8 = fault output</p>

¹ The default setting is shown **bold** / ² see Chapter 11 “Relay output / open-collector”, page 57

Parameter	Display	Setting range ¹
Switching point	ALAR.2	According to measuring range (in configured unit) 2.00 mS/cm
Hysteresis	HYS.2.	According to measuring range (in configured unit) 0.04 mS/cm (2% of range with range 0 – 2 mS/cm) or 5°C or 9°F
Pull-in delay	T.ON2	0– 2 –999 seconds
Drop-out delay	T.OFF2	0– 1 –999 seconds Note The parameter is only active if pulse time T.PUL2 = 0.
Pulse time	T.PUL2	0 –999 seconds, see Chapter 11 “Relay output / open-collector”, page 57
Response of logic output 2 in calibration mode	CAL.2	0 = inactive 1 = active 2 = remains in current state

¹ The default setting is shown **bold**.

Parameter	Display	Setting range ¹
Response to fault	ERR.2	0 = inactive 1 = active 2 = frozen (relay remains unchanged)
Manual mode	SIM.2	OFF = no manual mode 0 = inactive 1 = active
USP pre-contact	S.USP2	0— 20 —100% Note If the USP contact or the USP pre-contact is activated, temperature compensation FCT.TC is deactivated. See also Chapter 12.1 “USP pre-alarm”, page 63.

¹ The default setting is shown **bold**.

8.3 Analog outputs

8.3.1 Conductivity (submenu CO.OUT)

Parameter	Display	Setting range ¹
Type of standard signal	OUT.CO	0 = 0 – 20 mA 1 = 4 – 20 mA 2 = 20 – 0 mA 3 = 20 – 4 mA 4 = 0 – 10 V 5 = 2 – 10 V 6 = 10 – 0 V 7 = 10 – 2 V Note If the standard signal type OUT.CO is changed, manual operation of the output will be deactivated.

¹ The default setting is shown **bold**.

Parameter	Display	Setting range ¹
Start value for scaling	SCL.CO	According to measuring range (in configured unit) 0.00 mS/cm Note Between the scaling start value SCL.CO and the scaling end value SCH.CO there must be a difference of at least 10% of the measuring range.
End value for scaling	SCH.CO	According to measuring range (in configured unit) 2.00 mS/cm Note Between the scaling start value SCL.CO and the scaling end value SCH.CO there must be a difference of at least 10% of the measuring range.
Response to calibration mode	CAL.CO	0 = following 1 = current state is retained
Response to fault	ERR.CO	0 = LOW (e.g. 0 V) 1 = HIGH (e.g. 10 V)

¹ The default setting is shown **bold**.

Parameter	Display	Setting range ¹
Manual operation of the analog output for conductivity	SIM.CO	OFF = no manual mode 0 – 22 mA or 0 – 10.7 V

8.3.2 Temperature (submenu TE.OUT)

Parameter	Display	Setting range ¹
Type of standard signal	OUT.TE	0 = 0 – 20 mA 1 = 4 – 20 mA 2 = 20 – 0 mA 3 = 20 – 4 mA 4 = 0 – 10 V 5 = 2 – 10 V 6 = 10 – 0 V 7 = 10 – 2 V Note If the standard signal type OUT.TE is changed, manual operation of the output will be deactivated.

¹ The default setting is shown **bold**.

Parameter	Display	Setting range ¹
Start value for scaling	SCL.TE	<p>-10.0 to 224°C or 14 to 437°F</p> <p>Note Setting range and default setting depend on the selected temperature unit UNIT.T. Between the scaling start value SCL.TE and the scaling end value SCH.TE there must be a difference of at least 10% of the measuring range.</p>
End value for scaling	SCH.TE	<p>16 to 250.0°C or 59 to 482°F</p> <p>Note Setting range and default setting depend on the selected temperature unit UNIT.T. Between the scaling start value SCL.TE and the scaling end value SCH.TE there must be a difference of at least 10% of the measuring range.</p>

¹ The default setting is shown **bold**.

Parameter	Display	Setting range ¹
Response to calibration mode	CAL.TE	0 = following 1 = current state is retained
Response to fault	ERR.TE	0 = LOW (e.g. 0 V) 1 = HIGH (e.g. 10 V)
Manual operation of analog output for temperature	SIM.TE	OFF = no manual mode 0 – 22 mA or 0 – 10.7 V

¹ The default setting is shown **bold**.

9 Calibration

9.1 General

The cell constants of conductivity cells stray somewhat depending on the type and additionally change during operation (due to deposits such as lime, or as a result of wear). This results in a change of the output signal from the cell. It is therefore necessary that the user is able to compensate for the deviations of the cell constant from the nominal value, either by manual entry or an automatic calibration of the cell constant K_{rel} .

The conductivity of a solution varies with the temperature, so for correct measurement both the temperature and the temperature coefficient of the solution being measured must be known. The temperature can either be measured automatically with a temperature sensor, or set manually by the user. The temperature coefficient can be determined automatically by the conductivity transmitter, or entered manually.

The device uses the non-temperature compensated measurements ($TC = 0$) at two different temperatures (the reference temperature, e.g. 25°C, and a second temperature that will later on be the working temperature) to determine the temperature coefficient of the solution being measured.

The time intervals between calibrations depend on the conditions in which the cell is used.

The device can draw your attention to a scheduled calibration by means of the calibration timer.

see Chapter 13.7 “Calibration timer has run down”, page 65.

9.1.1 Measurements in highly-purified water

Measurements in highly-purified water (measured values < approx. 10 $\mu\text{S}/\text{cm}$) make special demands on the metrology and the measurement environment.

The following points should therefore be considered and checked first before attempting a calibration:

- Basically sensors with ASTM certificate are recommended for measurements in highly-purified water. Their cell constants are measured by the manufacturer and can be found in the certificate.
- Ready-to-use calibration solutions in the range < 5 $\mu\text{S}/\text{cm}$ are difficult or impossible to get. Effort and error rate are very high when handling these.
- Reliable comparative measurements are often problematic due to unknown or insufficient quality of the comparison device. In addition, the reference junction is often not close enough to the actual measuring point.
- When wiring pay attention to shielding and grounding and make sure that the conduction paths are short.
- If minor measurement errors exist despite of entering the exact cell constant, these can manually be adjusted in the range of several percent by changing the relative cell constant. Possible causes are installation conditions and flow dependencies.
- **Larger deviations (> approx. 10 %) mostly have other causes, such as contamination of the sensor by mishandling or EMC.**



More information on highly-purified water measurement in form of a scientific paper can be found on the Internet at **www.jumo.de**.

For this purpose, enter the keyword "FAS 614" into the search box.

9.2 Activating the calibration mode



The setup interface and the measurement inputs for conductivity and temperature are not electrically isolated. This means that, in unfavorable conditions, equalizing currents may flow when the PC interface is connected. These equalizing currents may result in damage to the devices connected.

However, there is no danger if the measurement circuit of the transmitter is electrically isolated from ground. If this is not assured, then one of the following safety measures should be taken:

- 1) Use a computer without electrical coupling to ground (e.g. battery-operated notebook). The computer must not be connected to a network.
- 2) Disconnect the measurement inputs of the transmitter before connecting the PC interface.



The device can be calibrated through the setup program or from the device keys.

The temperature coefficient and cell constant can also be manually entered.

The time-out function is not active during calibration!

* Press the  +  keys



Calibration mode activation from the keys must be enabled:

Press  > 2 sec / set ADMIN / CAL / CA.LVL to 1.

or

* Change to the calibration level through the menu see Chapter 6.4 “Level selection”, page 17

or Chapter 6.8 “The calibration level (CALIB)”, page 21



The code for enabling the calibration mode is:
110

or

* Start the calibration in the setup program.

9.3 Selecting the calibration procedure

Calibrating the temperature coefficient



* Confirm selection with \textcircled{P} .

continue with Chapter 9.4 “Calibrating the temperature coefficient using automatic temperature measurement”, page 46

or

Chapter 9.5 “Calibrating the temperature coefficient using manual temperature entry”, page 49

- or $\textcircled{\nabla}$

Calibrating the relative cell constant



- Confirm selection with \textcircled{P} .

continue with Chapter 9.6 “Calibrating the relative cell constant”, page 51.

9.4 Calibrating the temperature coefficient using automatic temperature measurement

Note

During calibration, the reference temperature and the working temperature can be approached in any sequence.

- * Immerse the conductivity cell and the temperature sensor in the medium to be measured.



blinks

The currently measured temperature is displayed.

WORK.T shows you that the working temperature that will be used later on has to be entered.

Note

The reference and working temperatures must differ by at least 5°C.

- * Enter the working temperature (e.g. 40.0 for 40.0°C), continue with \textcircled{P} .
- * Temper the medium to be measured to the reference temperature.



- The LC display shows the temperature in the upper line, and the uncompensated conductivity in the line below.

The conductivity value will be accepted automatically on reaching the reference temperature,

or

-
- the current value can be accepted immediately by pressing the \textcircled{P} key (for less than 1 second).



- When the first calibration point has been accepted, the lower line will show NEXT.

* Press the \textcircled{P} key.

* Temper the medium to be measured to the working temperature.



- The LC display shows the temperature in the upper line, and the uncompensated conductivity in the line below.
- The conductivity value will be accepted automatically on reaching the working temperature,

or

* the current value can be accepted immediately by pressing the \textcircled{P} key (for less than 1 second).



- The temperature coefficient that was calculated is displayed.

* Store the value by pressing \textcircled{P} (for more than 2 seconds) or

discard it by pressing the EXIT key.

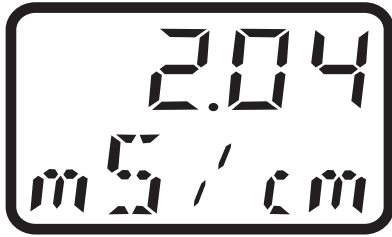

- The device will now show the currently present conductivity (the actual value).

Note

Possible errors: 2 identical calibration points or temperature coefficient larger than 5.5%

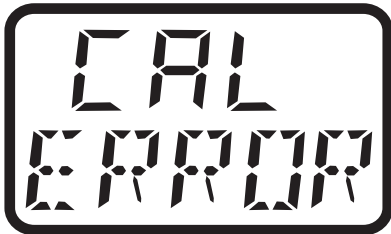

or

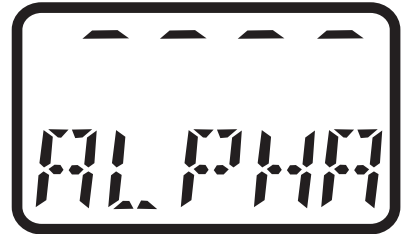

- The device indicates an error.
- * After pressing the \textcircled{P} key or EXIT, the selected calibration procedure is shown (see Chapter 9.3 “Selecting the calibration procedure”, page 45).



9.5 Calibrating the temperature coefficient using manual temperature entry

Note

During calibration, the reference temperature and the working temperature can be approached in any sequence.

- * Immerse the conductivity cell and the temperature sensor in the medium to be measured.



blinks

WORK.T shows you that the working temperature that will be used later on has to be entered.

Note

The reference and working temperatures must differ by at least 5°C.

- * Enter the working temperature (e.g. 40.0 for 40.0°C), continue with P .
- * Temper the medium to be measured to the reference temperature.



- The uncompensated conductivity is shown in the bottom line in the LC display.

- * The current value can be accepted immediately by pressing P (for less than 1 second).



- When the first calibration point has been accepted, NEXT will be shown in the bottom line.

* Press (P)

* Temper the medium to the working temperature.



- The uncompensated conductivity is shown in the bottom line in the LC display.

* The current value can be accepted immediately by pressing (P) (for less than 1 second).



- The temperature coefficient that was calculated is displayed.

* Store the value by pressing (P) (for more than 2 seconds) or discard it by pressing the EXIT key.



- The device now shows the present conductivity (actual value).

Note

Possible errors: 2 identical calibration points or temperature coefficient larger than 5.5%

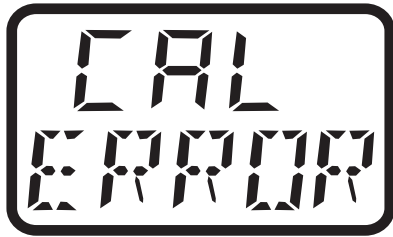

or

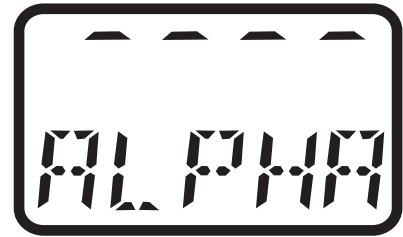

- The device indicates an error.

* After pressing the \textcircled{P} key or EXIT, the selected calibration procedure is shown.



9.6 Calibrating the relative cell constant

General

Because of manufacturing variations, each conductivity cell has a **real** cell constant which deviates slightly from the ideal **nominal** cell constant. The real cell constant may drift due to dirt accumulating on the cell.

This deviation of the real from the nominal cell constant is reflected by the relative cell constant. The relative cell constant is determined through calibration.

-
- * Immerse the conductivity cell into a solution with a known conductivity.

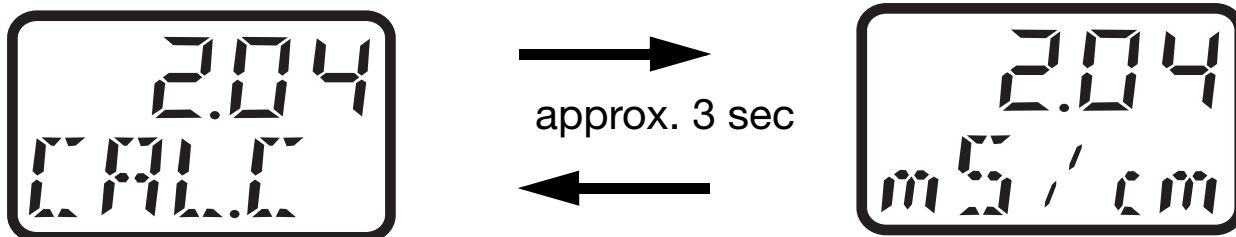

- The uncompensated conductivity of the reference solution (actual value) and CAL.C are shown in alternation.

- * As soon as the value displayed is stable: press \textcircled{P} (for less than 1 second).



- * Enter the actual conductivity of the reference solution (setpoint) with the $\textcircled{\blacktriangle}$ or $\textcircled{\blacktriangledown}$ key.
- * Press \textcircled{P} (for less than 1 second).



- The relative cell constant that was calculated is displayed.
- * Save the cell constant by pressing \textcircled{P} for more than 2 seconds or cancel by pressing EXIT.

Note

Possible errors: conductivity is 0 or the relative cell constant is

outside 20 – 500%.

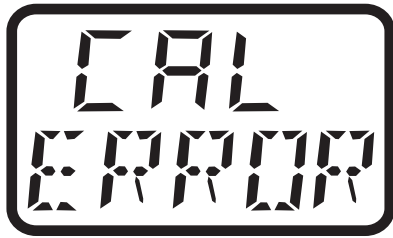

Conductivity = 0



< 20%



> 500%

* The device indicates an error.

After pressing (P) or EXIT, the selected calibration procedure is shown (see Chapter 9.3 “Selecting the calibration procedure”, page 45).

The latest valid measurement continues to be active.



10 Analog output



The analog outputs are configured at the operator level (USER) or the administrator level (ADMIN) in CO.OUT (conductivity output) and TE.OUT (temperature output) see Chapter 6.5 “The operator level (USER)”, page 18.

10.1 Response of the output signal during calibration

You can choose between “following” or “unchanged” (constant).

10.2 Response of the output signal to a fault condition

If any of the following errors occurs, the output signal moves to a defined state (see Chapter 10.3 “Output signal in fault condition”, page 55) :

Analog output for conductivity with inactive temperature compensation

- Underrange, conductivity
- Overage, conductivity

Analog output for conductivity with active temperature compensation

- Underrange, conductivity
- Overage, conductivity
- Underrange, temperature
- Overage, temperature

Analog output for temperature

- Underrange, temperature
- Overage, temperature



On leaving the compensation ranges given below, the analog output for conductivity as well as the analog output for temperature will move to the configured fault conditions:

USP: 0 to 100°C
ASTM: 0 to 100°C
Natural water: 0 to 36°C

10.3 Output signal in fault condition

Depending on the configuration, the output signal can adopt the LOW or HIGH condition in the event of a fault.

Output signal nominal	Output signal HIGH	Output signal LOW
0 – 20 mA	22.0 mA	0 mA
4 – 20 mA	22.0 mA	3.4 mA
0 – 10 V	10.7 V	0 V
2 – 10 V	10.7 V	1.4 V

10.4 Response of the output signal on leaving the scaling range

On leaving the scaling range, the output will, up to a defined limit, produce a proportional signal (as per NAMUR NE43). These limits are listed in the table below:

Below scaling range	Within scaling range	Above scaling range
0.0 mA	0 – 20 mA	20.5 mA
3.8 mA	4 – 20 mA	20.5 mA
0.0 V	0 – 10 V	10.2 V
20.5 mA	20 – 0 mA	0.0 mA
20.5 mA	20 – 4 mA	3.8 mA
10.2 V	10 – 0 V	0.0V
1.8 V	2 – 10V	10.2 V
10.2 V	10 – 2 V	1.8 V

10.5 Manual operation of the analog output

The JUMO ecoTRANS Lf 03 can output a constant analog signal, for test purposes or commissioning, see also Chapter 11.2 “Manual operation of the relay outputs”, page 57.



After a supply failure, manual mode is deactivated.

11 Relay output / open-collector

11.1 Response of the relay

Depending on the setting, the JUMO ecoTRANS Lf 03 monitors a limit, similar to a limit comparator (LK), as a MAX LK or MIN LK. The hysteresis is asymmetric with respect to the limit.

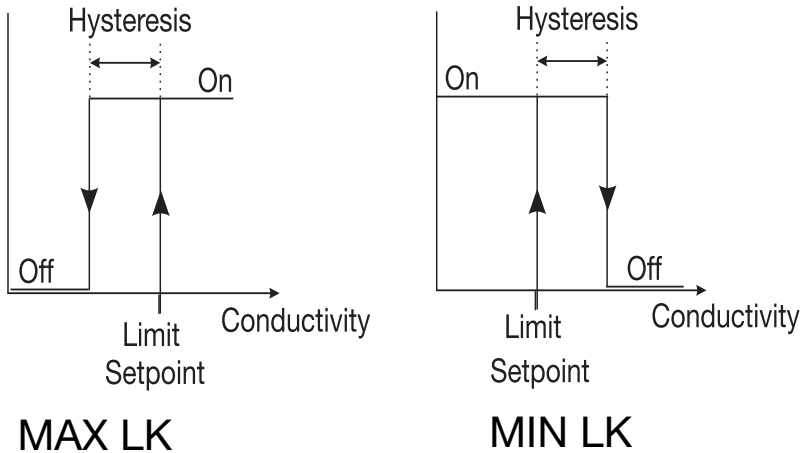

11.2 Manual operation of the relay outputs

The transmitter can output a **constant** signal, for test purposes or commissioning a system.

The parameter USER / BIN.1 (or BIN.2) / SIM.1 (or SIM.2) can be used to set manual operation to:

- OFF = no manual mode
- 0 = inactive
- 1 = active => the “S” LED is on

Indication of manual mode



If one of the outputs is in manual mode, this will be indicated by displaying “S” or “-”, in alternation with the actual value.

“S” means the corresponding output is in manual mode.

“-” means the corresponding output is not in manual mode.

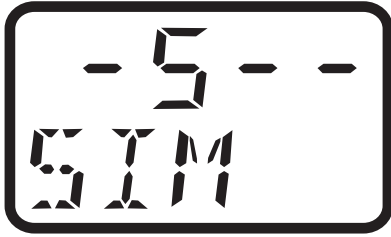

- 1st place: analog output for conductivity
- 2nd place: analog output for temperature
- 3rd place: logic output 1
- 4th place: logic output 2 (if available)

In the example above, the analog temperature output is in manual mode, all other outputs are not.

On leaving the manual mode, the output signal immediately takes on the value that is proportional to the measured conductivity or temperature value.

After power-on, manual mode is always deactivated.

11.3 Response of the relay during calibration

The parameter USER / BIN.1 (or BIN.2) / CAL.1 (or CAL.2) can be used to set the relay response to:

0 = relay inactive

1 = relay active

2 = relay unchanged

(during calibration, the relay remains at the status that was valid before the start of the calibration)

11.4 Pulse function of the relay output

The limit comparator is reset after an adjustable pulse time. The parameter available for this purpose is: USER / BIN.1 (or BIN.2) / T.PUL1 (or T.PUL2).

It can be set from 0 = 0 seconds (no pulse function)

to 999 = 999 seconds.

The LED K1 is lit up red as long as the switching condition is fulfilled.



Switch-off delay is not possible in pulsed operation.

11.5 Response of the relay in fault condition

The parameter USER / BIN.1 (or BIN.2) / ERR.1 (or ERR.2) can be used to set the relay response to:

0 = relay inactive

1 = relay active

2 = relay unchanged

(during calibration, the relay remains at the status that was valid before the start of the calibration).

Function	Conductivity		Temperature	
	Under-range	Over-range	Under-range	Over-range
Limit comparator, conductivity without temperature compensation	x	x		
Limit comparator, conductivity with temperature compensation	x	x	x	x
Limit comparator, temperature			x	x
Calib. timer run down	x	x	x	x
Fault output	x	x	x	x

11.6 Fault detection

The relay output becomes active if any of the following errors occur:

Limit comparator for conductivity with inactive temperature compensation

- Underrange, conductivity
- Overage, conductivity

Limit comparator for conductivity with active temperature compensation

- Underrange, conductivity
- Overage, conductivity
- Underrange, temperature
- Overage, temperature

Limit comparator for temperature

- Underrange, temperature
- Overage, temperature

Calibration timer

- Time exceeded



On leaving the compensation ranges given below, the limit comparator for conductivity as well as the limit comparator for temperature will switch:

USP:	0 to 100°C
ASTM:	0 to 100°C
Natural water:	0 to 36°C

12 The USP contact (for high-purity water)

The USP contact enables the monitoring of the high-purity water quality in accordance with the requirements of USP <645>. USP <645> includes a table that specifies a limit for the conductivity as a function of temperature. If the conductivity remains below the limit, then the high-purity water fulfills the requirements of USP <645>.

If, at a given temperature, the conductivity of the water is higher than specified in the USP table, the USP contact of the JUMO ecoTRANS Lf 03 will switch.

The limits are defined in steps; at 8°C, for example, a value of 5°C is applied.

Note

Temperature compensation must be switched off (temperature coefficient = 0) during monitoring.

Set the parameter USER / CON / ALPHA to 0.0.

Extract from USP <645>

Temperature °C	Max. conductivity μS/cm (uncomp.)	Temperature °C	Max. conductivity μS/cm (uncomp.)
0	0.6	55	2.1
5	0.8	60	2.2
10	0.9	65	2.4
15	1.0	70	2.5
20	1.1	75	2.7
25	1.3	80	2.7
30	1.4	85	2.7
35	1.5	90	2.7
40	1.7	95	2.9
45	1.8	100	3.1
50	1.9		

If the conductivity exceeds the value for the corresponding temperature, the configured contact will switch.

12.1 USP pre-alarm

The USP pre-alarm switches before the water quality reaches the set limit.

The parameter: USER / BIN.1 / S.USP1 (0 – 100) can be used to define a margin between pre-alarm and USP limit, as a percentage value referred to the active limit.

13 Display and LED messages

13.1 Operating states of the JUMO ecoTrans Lf 03

Two LEDs indicate the operating states

Device status	LED red (top)	LED yellow (bottom)
Normal operation	off	on, when LK1 is active
Error	blinks	on, when LK1 is active
Initialization	off	off

13.2 Underrange



or

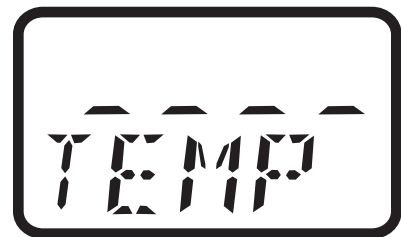

Below measuring range

13.3 Overrange



or



Above measuring range

13.4 Probe break



No sensor break detection for conductivity, since the value 0 mS/cm is within the measuring range!

13.5 Short circuit

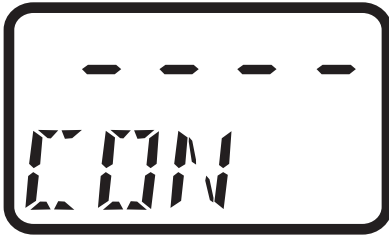

or

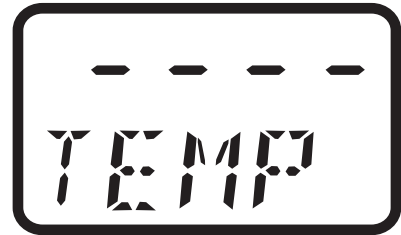

13.6 Initialization of dependent parameters

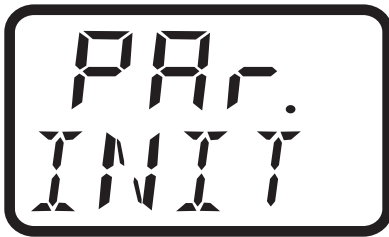

After altering one parameter, other dependent parameters are altered automatically.



Please check all dependent parameters!

13.7 Calibration timer has run down

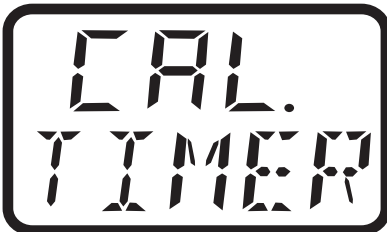

In accordance with the specifications (of the plant manufacturer, for example), calibration of the cell constant and/or of the temperature coefficient should be carried out.

14 Operation via setup interface

PC or notebook with RS232 interface

Operating system:

- Windows '98®
- Windows 2000®
- Windows XP®
- Windows NT® 4.0 or higher

JUMO ecoTRANS Lf 03

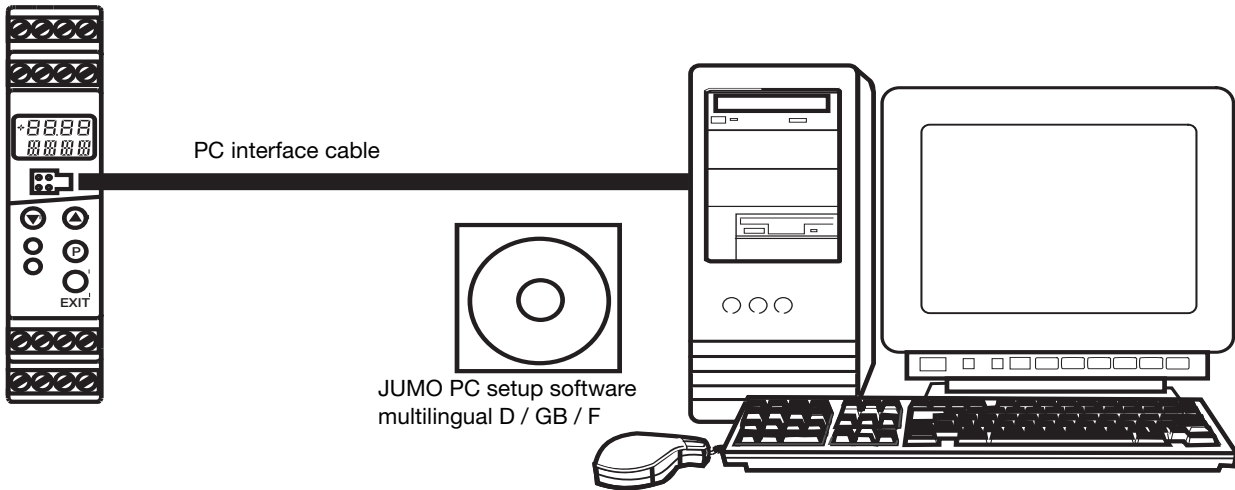

Caution

The setup interface and the measurement inputs for conductivity and temperature are not electrically isolated. This means that, in unfavorable conditions, equalizing currents may flow when the PC interface is connected. These equalizing currents may result in damage to the devices connected.

However, there is no danger if the measurement circuit of the transmitter is electrically isolated from ground. If this is not assured, then one of the following safety measures should be taken:

- 1) Use a computer without electrical coupling to ground (e.g. battery-operated notebook).
The computer must not be connected to a network.
- 2) Disconnect the measurement inputs of the transmitter before connecting the PC interface.
- 3) No additional measuring cells or probes must be in the medium during calibration, as this could result in measurement and calibration errors!

14.1 Operation through Setup

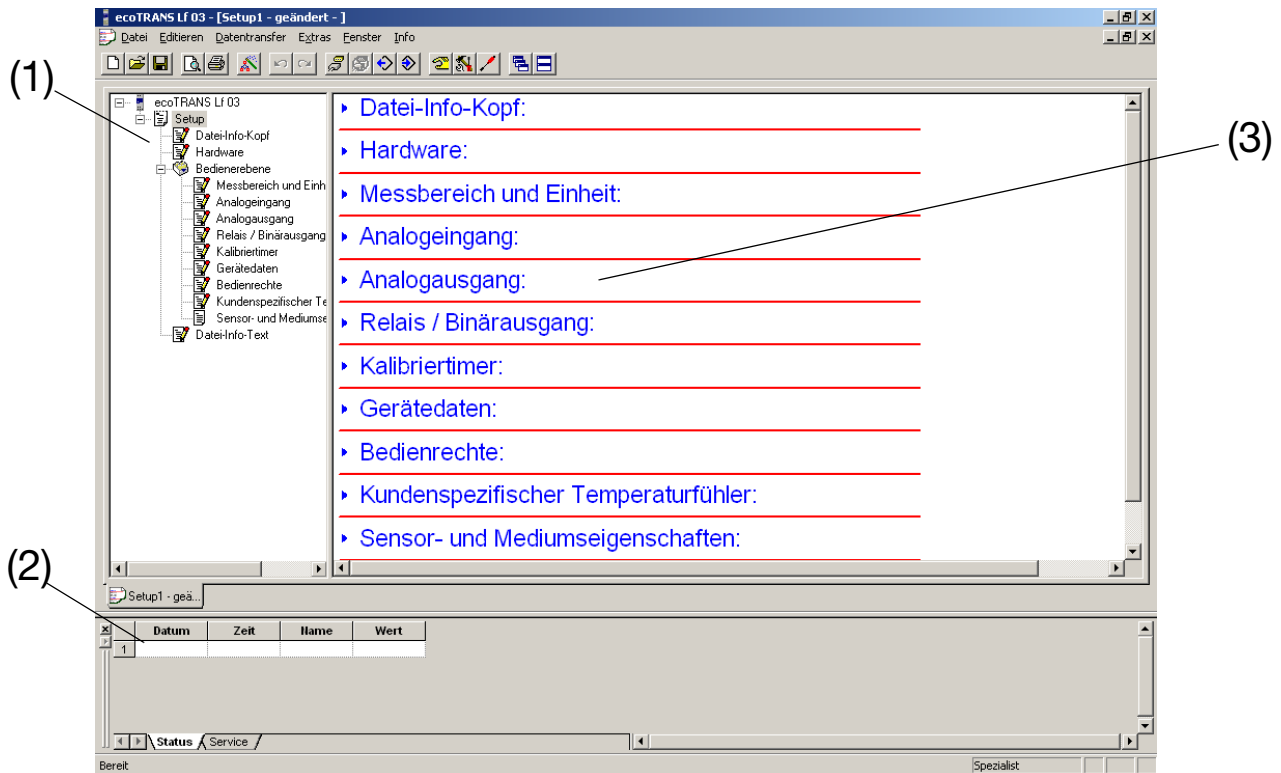

(1)	Navigation tree The navigation tree allows quick access (double-click) to the individual setting options.
(2)	Diagnosis window As soon as a connection with a device has been established, the latest data are shown here.
(3)	Working area If you click on the arrow (▶), the setting options will be shown. A double-click on the text will call up the corresponding editing window.

Customized linearization for the temperature probe

A table for 30 value pairs can be used to adapt any temperature probe to the temperature input of the JUMO ecoTRANS Lf 03.

15 Technical data

Conductivity input

Electrolytic conductivity cells with the cell constants 0.01; 0.1; 1.0; 3.0; 10.0 $1/\text{cm}$ (2-electrode principle).

The cell constant can be adjusted over the range 20 – 500%.

Lead compensation, conductivity input

The effect of long cables can be compensated on ranges larger than about 20 mS/cm by entering the lead resistance, within the range from 0.00 to 99.99 Ω .

Measuring range

0 – 1 μS to 0 – 200 mS, depending on the cell constant, see Chapter 7 “Setting ranges”, page 22 for details.

Deviation from characteristic, conductivity

see Chapter 7 “Setting ranges”, page 22.

Reference temperature (for temperature compensation)

settable from 10 to 40°C (factory setting: 25°C)

Temperature range

-10 to +250°C (depending on the temperature probe configured)

Deviation from characteristic, temperature

Pt100/Pt1000 : $\leq 0,6$ % of the measuring range

NTC 2k Ω : $\leq 1,5$ % of the measuring range

NTC UUA : $\leq 2,0$ % of the measuring range

KTY11-6 : $\leq 0,8$ % of the measuring range

with customer-specific characteristic: ≤ 5 Ω .

Analog input, temperature

- max. measurable resistance: 4500 Ω

- resistance thermometer Pt100 or Pt1000
measuring range: -10 to +250°C

- NTC 2K
measuring range: 0 to +150°C

resistance: 2 k Ω at 25°C

A parallel resistor with 8.2 k Ω is required!

- NTC 2K25

measuring range: 0 to +150°C

resistance: 2.25 k Ω at 25°C

A parallel resistor with 8.2 k Ω is required!

- KTY11-6

measuring range: -10 to +150°C

resistance: 2 k Ω at 25°C

- All temperature probes can be connected in 2-, 3- or 4-wire circuit.

- Customer-specific characteristic (through setup program)

measuring range: 30 — 4500 Ω / -10°C to +250°C

characteristic with 30 calibration points

Zero-point calibration, temperature input

Zero-point errors caused by the system can be compensated within the range -20 to +20°C.

Analog outputs

freely configurable:

0(2) — 10V $R_{load} \geq 2 \text{ k}\Omega$ or

10 — 0(2)V $R_{load} \geq 2 \text{ k}\Omega$ or

0(4) — 20mA $R_{load} \leq 400 \Omega$ or

20 — 0(4)mA $R_{load} \leq 400 \Omega$

electrically isolated from the inputs:

$\Delta U \leq 30 \text{ V AC}$ or

$\Delta U \leq 50 \text{ V DC}$

Deviation of the analog output signal

$\pm 0.015 \text{ mA}$ or $\pm 5 \text{ mV}$ $\pm 50 \text{ ppm/K}$

Relay output

changeover contact

contact rating: 8 A, 250 V AC, with resistive load

8 A, 24 V DC with resistive load

current rating 8 A

contact life: > 100, 000 operations at rated load

Open-collector output

contact rating: 100 mA, 35 V DC with resistive load,
voltage drop in the switched state
 $\leq 1.2\text{V}$, not short-circuit proof

A/D converter

resolution 14 bit

Sampling time

500 msec = 2 measurements per second

Ambient temperature error

$\leq 0.5\%/10\text{ }^\circ\text{C}$

Measuring circuit monitoring

conductivity input:
out-of-range, short-circuit

temperature input:
out-of-range, probe short-circuit, probe break

In a fault condition, the outputs adopt a defined (configurable) state.

Data backup

EEPROM

Supply voltage

20 – 30V DC, ripple < 5%
power drawn $\leq 3\text{ W}$,
with reverse-polarity protection

Electrical connection

screw terminals up to 2.5 mm^2

Permissible ambient temperature

operating temperature range: 0 to $+50\text{ }^\circ\text{C}$
functional temperature range: -10 to $+60\text{ }^\circ\text{C}$

Permissible storage temperature

-25 to +75°C

Climatic conditions

rel. humidity \leq 93 % no condensation

Protection (to EN 60 529)

IP20

Electrical safety

to EN 61 010

clearance and creepage distances for

- overvoltage category II

- pollution degree 2

Electromagnetic compatibility

to EN 61 326

interference emission: Class B

interference immunity: to industrial requirements

Housing

housing for DIN rail mounting: PC (polycarbonate)

Mounting

on a 35 x 7.5 mm DIN rail to EN 60 715

Operating position

unrestricted

Weight

approx. 150g

16 Environment / waste disposal

Faulty devices can be returned to JUMO for proper disposal.

17 China RoHS

		有毒有害物质或元素 Hazardous substances						
		铅 (Pb)	汞 (Hg)	镉 (Cd)	六价铬 (Cr(VI))	多溴联苯 (PBB)	多溴二苯醚 (PBDE)	
部件名称	Product group: 202723							
外壳 Housing (Gehäuse)		○	○	○	○	○	○	○
过程连接 Process connection (Prozessanschluss)		○	○	○	○	○	○	○
螺母 Nut (Mutter)		○	○	○	○	○	○	○
螺钉 Screw (Schraube)		○	○	○	○	○	○	○

本表格依据 SJ/T 11364-2014 的规定编制。
 (This table is prepared in accordance with the provisions of SJ/T 11364-2014.)
 O : 表示该有害物质在该部件所有均质材料中的含量均在 GB/T 26572 规定的限量要求以下。
 (O: Indicates that said hazardous substance contained in all of the homogeneous materials for this part is below the limit requirement of GB/T 26572.)
 X : 表示该有害物质至少在该部件的某一均质材料中的含量超出 GB/T 26572 规定的限量要求。
 (X: Indicates that said hazardous substance contained in one of the homogeneous materials used for this part is above the limit requirement of GB/T 26572.)



JUMO GmbH & Co. KG

Street address:
Moritz-Juchheim-Straße 1
36039 Fulda, Germany
Delivery address:
Mackenrodtstraße 14
36039 Fulda, Germany
Postal address:
36035 Fulda, Germany
Phone: +49 661 6003-0
Fax: +49 661 6003-607
Email: mail@jumo.net
Internet: www.jumo.net

JUMO Instrument Co. Ltd.

JUMO House
Temple Bank, Riverway
Harlow, Essex CM 20 2DY, UK
Phone: +44 1279 63 55 33
Fax: +44 1279 62 50 29
Email: sales@jumo.co.uk
Internet: www.jumo.co.uk

JUMO Process Control, Inc.

6733 Myers Road
East Syracuse, NY 13057, USA
Phone: +1 315 437 5866
Fax: +1 315 437 5860
Email: info.us@jumo.net
Internet: www.jumousa.com