

JUMO MAERA

Level probes

Types 401015, 402090, 404391, 404392



Installation Instructions



40101500T94Z001K000

V10.00/EN/00588054/2021-03-03

1	Safety information	6
2	Intended use	7
3	Identifying the device version	8
3.1	Nameplate	8
3.2	Order details	8
3.2.1	JUMO MAERA S25 (type 401015)	9
3.2.2	JUMO MAERA S26 (type 402090)	11
3.2.3	JUMO MAERA F27 (type 404391)	13
3.2.4	JUMO MAERA S28 (type 404392)	15
3.2.5	Cutting ring fitting	16
3.2.6	Improved moisture and vibration protection	18
3.3	Accessories	19
3.3.1	Cable clamp	19
3.3.2	Sealing screw	19
3.3.3	Terminal case with pressure compensation element	20
3.3.4	Pressure compensation filter for cable	20
3.3.5	Hose end piece	21
3.3.6	Terminal head for pressure compensation	22
3.4	Scope of delivery	23
3.5	Goods acceptance	23
3.6	Storage	23
4	Mounting	24
4.1	Dimensions	26
4.1.1	JUMO MAERA S25 (type 401015)	26
4.1.2	JUMO MAERA S26 (type 402090)	27
4.1.3	JUMO MAERA F27 (type 404391)	29
4.1.4	JUMO MAERA S28 (type 404392)	30
5	Installation	32
5.1	Connection diagram	32
5.1.1	JUMO MAERA S25 (type 401015)	33
5.1.2	JUMO MAERA S26 (type 402090)	34
5.1.3	JUMO MAERA F27 (type 404391)	35
5.1.4	JUMO MAERA S28 (type 404392)	36
5.2	Operation	36

Contents

6	Technical data	37
6.1	JUMO MAERA S25 (type 401015)	37
6.1.1	General Information	37
6.1.2	Measuring range and accuracy	37
6.1.3	Output	37
6.1.4	Electrical data	38
6.1.5	Electrical connection	38
6.1.6	Mechanical features	38
6.1.7	Environmental influences	39
6.2	JUMO MAERA S26 (type 402090)	40
6.2.1	General Information	40
6.2.2	Measuring range and accuracy	40
6.2.3	Output	41
6.2.4	Electrical data	41
6.2.5	Electrical connection	42
6.2.6	Mechanical features	42
6.2.7	Environmental influences	43
6.2.8	Approvals and approval marks	43
6.3	JUMO MAERA F27 (type 404391)	44
6.3.1	General Information	44
6.3.2	Measuring range and accuracy	44
6.3.3	Output	45
6.3.4	Electrical data	45
6.3.5	Electrical connection	45
6.3.6	Mechanical features	46
6.3.7	Environmental influences	46
6.4	JUMO MAERA S28 (type 404392)	47
6.4.1	General Information	47
6.4.2	Measuring range and accuracy	47
6.4.3	Output	47
6.4.4	Electrical data	48
6.4.5	Electrical connection	48
6.4.6	Mechanical features	49
6.4.7	Environmental influences	49
6.4.8	Approvals and approval marks	49
7	Malfunctions/faults	50
8	Declaration of conformity	52

9	Maintenance, cleaning and returns	64
9.1	Maintenance64
9.2	Cleaning64
9.3	Returns64
10	China RoHS	65

1 Safety information

Warning symbols



DANGER!

This symbol indicates that **personal injury from electrocution** may occur if the appropriate precautionary measures are not taken.



CAUTION!

This symbol in connection with the signal word indicates that **material damage or data loss** will occur if the respective precautionary measures are not taken.



READ THE DOCUMENTATION!

This symbol, which is attached to the device, indicates that the associated **documentation for the device** must be **observed**. This is necessary to identify the nature of the potential hazard, and to take measures to prevent it.

Note symbols



NOTE!

This symbol refers to **important information** about the product, its handling, or additional benefits.



DISPOSAL!

At the end of its service life, the device and any batteries present do not belong in the trash! Please ensure that they are **disposed of** properly and in an **environmentally friendly** manner.



NOTE!

Level probes are used to carry out hydrostatic level measurements in **ventilated** tanks or to gauge water levels in open waters.

The **correct level probe** should be selected with regard to the measuring range, version and specific measuring conditions on site prior to mounting, installation and startup! The specifications provided by the manufacturer are intended as suggestions only, except those relating to the test series. The decision is to be made by the operator!

In order to prevent damage to the level probe and to safeguard its process, mounting, installation and startup must only be performed by **qualified personnel**. Personnel must be familiar with country-specific regulations and be aware of applied standards and directives to prevent bodily injuries and material damage. Qualified personnel must have read the operating manual, noted the nameplate and understood both so that the instructions can be followed. Modifications and repairs must only be carried out if the operating manual permits it.

Improper operation may impair the safe operation of the device. Please be aware that the manufacturer shall not be held liable for damage caused by improper handling or in the event of use contrary to the intended purpose.

3 Identifying the device version

3.1 Nameplate

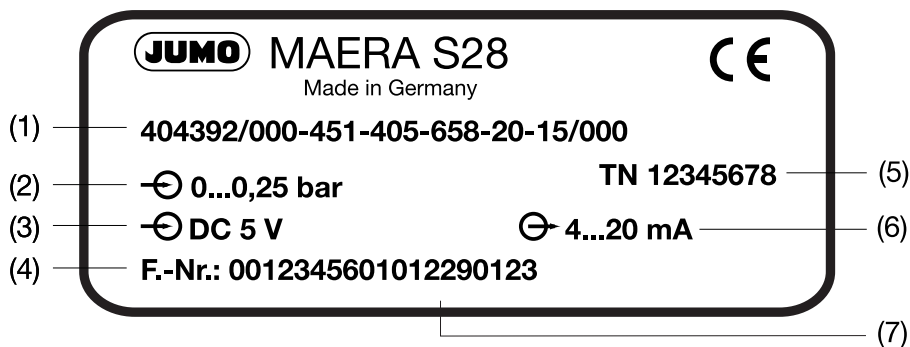

- (1) Order code
- (2) Measuring range
- (3) Voltage supply
- (4) Serial number
- (5) Part no.
- (6) Output signal
- (7) Date of manufacture
2912 = 2012/29 (year/calendar week)

3.2 Order details

The order details are composed of features. These are described in the technical data for the device:

- From chapter 6.1 "JUMO MAERA S25 (type 401015)", Page 37
- From chapter 6.2 "JUMO MAERA S26 (type 402090)", Page 40
- From chapter 6.3 "JUMO MAERA F27 (type 404391)", Page 44
- From chapter 6.4 "JUMO MAERA S28 (type 404392)", Page 47

3 Identifying the device version

3.2.1 JUMO MAERA S25 (type 401015)

(1) Basic type	
401015/000	JUMO MAERA S25 – level probe
401015/999	JUMO MAERA S25 – level probe, special version
(2) Input	
451	0 to 0,25 bar relative pressure
452	0 to 0,4 bar relative pressure
453	0 to 0,6 bar relative pressure
454	0 to 1 bar relative pressure
(3) Output	
405	4 to 20 mA, two-wire
412	DC 0.5 to 4.5 V, three-wire
415	DC 0 to 10 V, three-wire
418	DC 1 to 5 V, three-wire
420	DC 1 to 6 V, three-wire
(4) Process connection	
567	G 1/4 inside
659	Connection open at the bottom
707	M3 (× 0.5) inside
(5) Process connection material	
20	CrNi (stainless steel)
(6) Electrical connection type	
11	Attached cable
(7) Protective hose	
1	PE protective hose (not UV resistant)
2	PA protective hose (not UV resistant)
3	PA protective hose (UV resistant)
(8) Cable length of the connecting cable	
005	5 m
010	10 m
025	25 m
(9) Extra codes	
000	None
691	Improved moisture and vibration protection

Order code **(1)** **(2)** **(3)** **(4)** **(5)** **(6)** **(7)** **(8)** **(9)**
 - - - - - - - /
Order example 401015/000 - 452 - 405 - 707 - 20 - 11 - 1 - 005 / 000

Accessories

Designation	Part no.
Terminal head for pressure compensation	
Tank cover mounting	00602743
Wall mounting	00602744

3 Identifying the device version

Scope of delivery

Designation

Hose end piece



CAUTION!

The non UV-resistant cable is not suitable for outdoor use.

3 Identifying the device version

3.2.2 JUMO MAERA S26 (type 402090)

(1) Basic type	
402090/000	JUMO MAERA S26 – Level probe
402090/023	JUMO MAERA S26 – Level probe with improved accuracy ^a
402090/999	JUMO MAERA S26 – Level probe, special version ^b
(2) Input	
451	0 to 0.25 bar relative pressure
452	0 to 0.4 bar relative pressure
453	0 to 0.6 bar relative pressure
454	0 to 1 bar relative pressure
455	0 to 1.6 bar relative pressure
456	0 to 2.5 bar relative pressure
457	0 to 4 bar relative pressure
458	0 to 6 bar relative pressure
459	0 to 10 bar relative pressure
999	Special measuring range for relative pressure ^c
(3) Output	
402	0 to 20 mA, three-wire
405	4 to 20 mA, two-wire
406	4 to 20 mA, three-wire
412	0.5 to 4.5 V, three-wire
415	0 to 10 V, three-wire
418	1 to 5 V, three-wire
420	1 to 6 V, three-wire
(4) Process connection	
567	G 1/4 inside
658	Connection closed at the bottom
659	Connection open at the bottom
759	Mounted protective cage Ø 95 mm
(5) Process connection material	
20	CrNi (stainless steel)
(6) Electrical connection type	
14	PUR cable, pebble gray, shielded, UV-resistant
15	PE-LD cable, black, shielded, UV-resistant
25	FEP cable, black, shielded, UV-resistant
26	Submersible motor cable, EPR cable, blue ^d
(7) Cable length of the connecting cable	
005	5 m
010	10 m
...	...
100	100 m

3 Identifying the device version

(8) Extra codes	
000	None
067	CSA approval
593	Cutting ring fitting (preparation for protection tube)
631	Improved moisture and vibration protection
881	Drinking water approval ^e
917	EPDM seal

^a Measuring devices with improved accuracy can only be supplied with output 4 to 20 mA, two-wire, **and** measuring ranges from 0 to 0.6 bar.

^b Without CSA approval

^c Measuring ranges up to 10 bar (100 mWS) are available with CSA approval.

^d Only available with 4 to 20 mA, two-wire.

^e Only available with EPDM seal, PE-LED cable, and submersible motor cable, EPR cable.

	(1)	(2)	(3)	(4)	(5)	(6)	(7)	(8)
Order code								
Order example	402090/000	- 454	- 405	- 659	- 20	- 15	- 010	/ 000

Accessories

Designation	Part no.
Terminal case with pressure compensation element	00061206
Cable clamp ^a	00061389
Sealing screw	00333329

^a The hot-dip galvanized case is made of steel sheet. The clamping jaws and guide clips are made of fiberglass-reinforced PA molding compound.

3 Identifying the device version

3.2.3 JUMO MAERA F27 (type 404391)

(1) Basic type	
404391/000	JUMO MAERA F27 – Level probe with ceramic measuring cell ^a
404391/007	JUMO MAERA F27 – Level probe with ceramic measuring cell with integrated temperature probe Pt100 ^{b, a}
404391/022	JUMO MAERA F27 – Level probe with ceramic measuring cell with case made of plastic PTFE ^c
404391/999	JUMO MAERA F27 – Level probe with ceramic measuring cell, special version
(2) Input	
412	0 to 50 mbar relative pressure
414	0 to 100 mbar relative pressure
415	0 to 160 mbar relative pressure
451	0 to 0.25 bar relative pressure
452	0 to 0.4 bar relative pressure
453	0 to 0.6 bar relative pressure
454	0 to 1 bar relative pressure
455	0 to 1.6 bar relative pressure
999	Special measuring range
(3) Output	
405	4 to 20 mA, two-wire
412	0.5 to 4.5 V, three-wire
(4) Process connection	
568	G 1 inside ^d
658	Connection closed at the bottom
659	Connection open at the bottom
(5) Electrical connection	
14	PUR cable, pebble gray, shielded, UV-resistant
15	PE-LD cable, black, shielded, UV-resistant
25	FEP cable, black, shielded, UV-resistant
(6) Length of the connecting cable	
005	5 m
010	10 m
...	...
100	100 m
999	Special length
(7) Extra codes	
000	None
593	Cutting ring fitting (preparation for protection tube) ^e
917	EPDM seal

^a Integrated overvoltage protection only possible in connection with output 4 to 20 mA.

^b The basic type 404391/007 is only available with output 4 to 20 mA, and process connection closed or open at the bottom.

^c The basic type 404391/022 is only available with process connection G 1 inside.

^d The process connection G 1 inside is only available with basic type 404391/022.

^e The extra code cutting ring fitting is only available in connection with basic type 404391/000 or 404391/007.

3 Identifying the device version

Order code (1) (2) (3) (4) (5) (6) (7)
 Order example - - - - - /
 404391/000 - 452 - 405 - 659 - 15 - 010 / 000

Accessories

Designation	Part no.
Terminal case with pressure compensation element	00061206
Cable clamp ^a	00061389
Sealing screw	00333329

^a The hot-dip galvanized case is made of steel sheet. The clamping jaws and guide clips are made of fiberglass-reinforced PA molding compound.

Scope of delivery

Designation	Part no.
Pressure compensation filter for cable	00382632

3 Identifying the device version

3.2.4 JUMO MAERA S28 (type 404392)

(1) Basic type	
404392/000	JUMO MAERA S28 – Level probe
404392/025	JUMO MAERA S28 – Level probe, deep well version ^a
404392/999	JUMO MAERA S28 – Level probe, special version
(2) Input	
451	0 to 0.25 bar relative pressure
452	0 to 0.4 bar relative pressure
453	0 to 0.6 bar relative pressure
454	0 to 1 bar relative pressure
455	0 to 1.6 bar relative pressure
456	0 to 2.5 bar relative pressure
457	0 to 4 bar sealed gauge
458	0 to 6 bar sealed gauge
459	0 to 10 bar sealed gauge
999	Special measuring range for relative pressure
(3) Output	
405	4 to 20 mA, two-wire
(4) Process connection	
567	G 1/4 inside
658	Connection closed at the bottom
659	Connection open at the bottom
759	Mounted protective cage Ø 95 mm
(5) Process connection material	
20	CrNi (stainless steel)
(6) Electrical connection	
14	PUR cable, pebble gray, shielded, UV-resistant
15	PE-LD cable, black, shielded, UV-resistant
25	FEP cable, black, shielded, UV-resistant
26	Submersible motor cable, EPR cable, blue
99	Special version
(7) Cable length of the connecting cable	
005	5 m
010	10 m
...	...
100	100 m
(8) Extra codes	
000	None
007	Integrated temperature probe Pt100
593	Cutting ring fitting (preparation for protection tube)
631	Improved moisture and vibration protection
881	Drinking water approval ^b
917	EPDM seal

3 Identifying the device version

- ^a The deep-well version was designed for use in measuring ranges from 0 to 4 bar up to 0 to 10 bar with a free-hanging cable length of up to 100 m. With regard to the area of application, the version is only available with a closed process connection, and an EPR cable without pressure compensation and without a temperature probe. Another benefit is the improved moisture and vibration protection. The user must always bear in mind that a stainless-steel version is not suitable for use in media containing chlorine, such as seawater.
- ^b Only available with EPDM seal, PE-LED cable and submersible motor cable, EPR cable.

	(1)		(2)		(3)		(4)		(5)		(6)		(7)		(8)
Order code		-		-		-		-		-		-		/	
Order example	404392/000	-	454	-	405	-	659	-	20	-	15	-	020	/	007, 631

Accessories

Designation	Part no.
Terminal case with pressure compensation element	00061206
Cable clamp ^a	00061389
Sealing screw	00333329

^a The hot-dip galvanized case is made of steel sheet. The clamping jaws and guide clips are made of fiberglass-reinforced PA molding compound.

Deep well version

The deep well version involves an enclosed atmosphere and is a sealed design (so-called sealed gauge).

The reference chamber is tightly sealed in a very high vacuum. The cell is calibrated to 1 bar. Therefore, when measuring the atmospheric pressure, the sensor measures almost 0 bar excess pressure. The maximum measurement error is thus approx. ±20 mbar depending on the variations in barometric pressure. The aim of this is to prevent aggressive gases, including those resulting from the pumping effect, which are caused by differences in temperature, leading to corrosion damage.

3.2.5 Cutting ring fitting

Extra code 593

For applications in which there is no durable cable outer sheath, installation can be enabled by applying a protection tube (diameter 12 mm) and corresponding fittings. In addition, there is a cutting ring fitting at the electrical output next to the cable that is used to mount the protection tube from the customer.

Mounting using the example of stainless steel

The level probe must be implemented as follows:

- With an electrical connection
- With a protection tube (majority made out of several tube sections)
- With straight-screw fittings for a sealed connection between the individual tube sections
- With straight screw-in fittings for mounting on the tank cover (not shown)

3 Identifying the device version

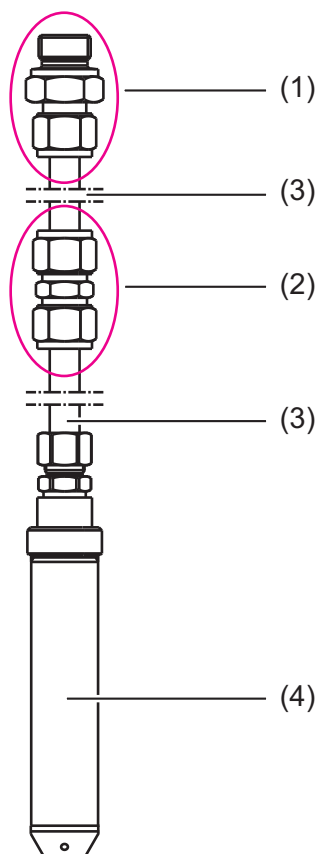

- | | |
|----------------------|----------------------------|
| (1) Screw-in fitting | (2) Straight-screw fitting |
| (3) Protection tube | (4) Level probe |

- 1) Lubricate the thread and the cone of the screw socket, as well as the union nut thread for the straight-screw fitting (double-side cutting ring fitting). Choose the lubricating paste that is suitable for the application.
- 2) Slide the first tube section over the cable towards the electrical connection of the measuring device.
- 3) To ensure proper tube cutting, the tube is guided to the stop of the pre-mounted fitting and the union nut is tightened by hand. Press the cutting ring with the help of the union nut. The cutting ring cuts the tube, creating tightness.
- 4) It is possible to visualize the pre-determined tightening distance with a vertical marking on the tube and straight-screw fitting.
- 5) For the straight-screw fitting made of stainless steel, tighten the union nut with a wrench by approx. 1/4 revolution beyond the point where a perceptible increase in force is noticed.
- 6) To inspect correct mounting, undo the union nut. The front cutting ring fitting is covered by the tube material. If that is not the case, tighten the fitting.



NOTE!

The extra code can be selected in connection with the level probes JUMO MAERA S26 (type 402090), JUMO MAERA F27 (type 404391) and JUMO MAERA S28 (type 404392).

3 Identifying the device version

3.2.6 Improved moisture and vibration protection

Extra codes 631, 691

Molded electrics protect the device from the influences of the climate, which may cause a measured value error due to the build-up of condensate, but may also cause the level probe to malfunction. Particularly in areas with warm media and cold environmental conditions or vice-versa, or high temperature fluctuations, a device with improved moisture and vibration protection should be chosen. This always applies to outdoor installations.

3 Identifying the device version

3.3 Accessories

3.3.1 Cable clamp

The wire holder, part no. 00061389, holds the probe in the liquid at a defined depth and provides strain relief. Use of the wire holder ensures that the cable is not deformed in an unacceptable manner.

The wire holder is compatible with all JUMO level probes.

The clamping range is 5.5 to 10.5 mm. The maximum tensile strength is 2.5 kN. The case is made of hot-dip galvanized steel sheet. The clamping jaws and guide clips are made of fiberglass-reinforced polyamide. A stainless steel variant is also available upon request.

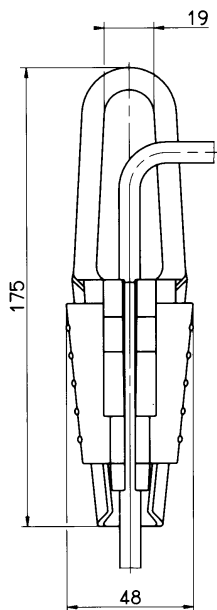

3.3.2 Sealing screw

For closed containers or water wells with a well head, the cable should be guided through a sealing screw, part no. 00333329 and secured. The sealing screw is made up of a G 1 1/2" thread and is used to route the cable.

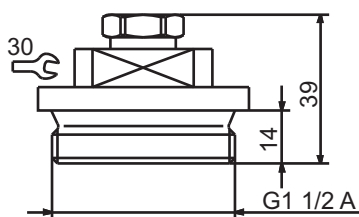

3 Identifying the device version

3.3.3 Terminal case with pressure compensation element

The terminal case, part no. 00061206, is used for secure installation of the level probe cable. The end of the pressure equalization hose is always protected from deposits and condensation (IP65). The remaining distribution can be performed with a standard cable without a pressure equalization hose.

The terminal case should be mounted as close as possible to the medium surface whilst still outside the medium to ensure the system is implemented cost-effectively and in the best possible way.

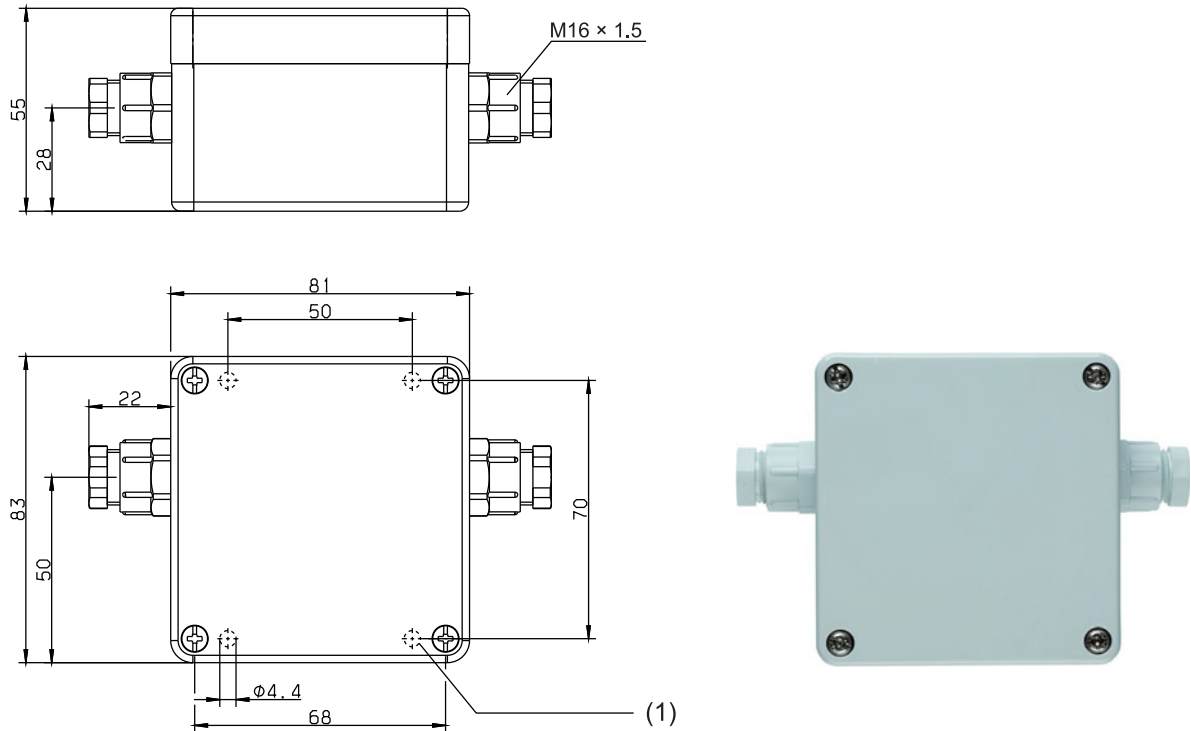

(1) Fastening hole



NOTE!

Please note that a hose end piece should be used with the level probe JUMO MAERA S25 (type 401015), see chapter 3.3.5 "Hose end piece", Page 21.

3.3.4 Pressure compensation filter for cable

The pressure compensation filter, part. no. 00382632, is a breathable filter that ensures aeration and ventilation without moisture penetration. This is attached to the end of the special cable.



NOTE!

The pressure compensation filter for the cable can be used in the product series JUMO MAERA S26 (type 402090), JUMO MAERA F27 (type 404391) and JUMO MAERA S28 (type 404392).

For the level probe JUMO MAERA F27 (type 404391), the pressure compensation filter is a standard accessory and included in the scope of delivery.

3 Identifying the device version

3.3.5 Hose end piece



NOTE!

The hose end piece is only suitable for use in the level probe variant JUMO MAERA S25 (type 401015) and is included in the delivery.

With this device, a standard cable is encased in a protective hose suitable for the application. The hose end piece prevents the hose, which is used as a pressure compensation hose, from being cut off or bent, for example when being routed through a wall. The hose end piece may be used for example in routing through walls in masonry, clamp or cutting ring fittings in a tank or cable connections in a control cabinet.

We are happy to help with any questions regarding accessories.

Mounting the hose end piece in an external pressure equalization hose

- 1) Trim the pressure equalization hose.
- 2) Slide the hose clamp over the cable.
- 3) Slide on the hose end piece.
- 4) Press in the hose clamp.

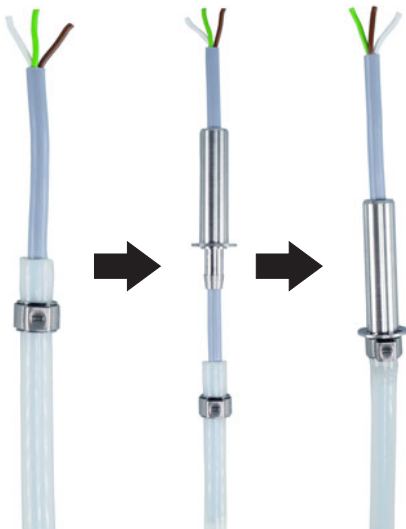

3 Identifying the device version

3.3.6 Terminal head for pressure compensation



NOTE!

The terminal head for pressure compensation is only suitable for use in the level probe variant JUMO MAERA S25 (type 401015).

The terminal head for pressure compensation is used to ensure the optimal and cost-effective installation of level probes. It meets the protection type IP67. By using it locally, which can be achieved using the tank mounting (part no. 00602743) or wall mounting (part no. 00602744) versions, a rapid pressure compensation can be achieved and the length of the special cable can be minimized. The costs are thereby reduced as an electric standard cable can be used as the outgoing cable from the terminal head. Furthermore the direction, for example to the control cabinet, can be individually specified.

The electrical connection and further information are described in the enclosed installation instructions.

Tank cover mounting

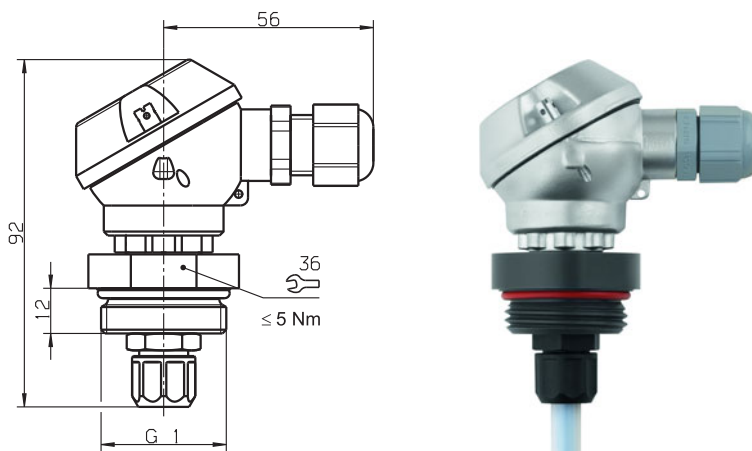

Wall mounting

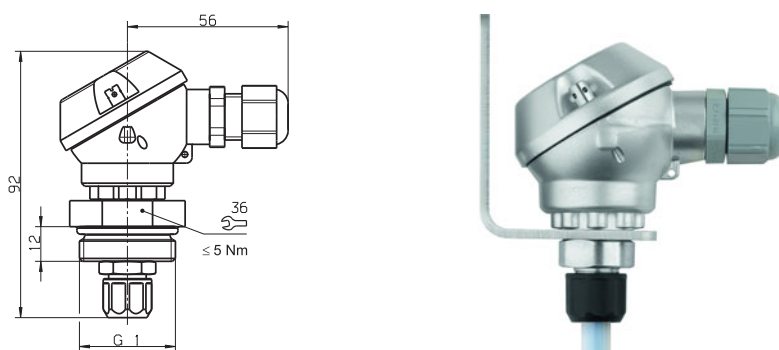

3 Identifying the device version

3.4 Scope of delivery

The scope of delivery includes:

- The device in the version ordered
- Installation instructions
- Optional: accessories, see chapter 3.3 "Accessories", Page 19

3.5 Goods acceptance

Is the packaging damaged?

Is the scope of delivery complete and corresponds to the order?

Is the device showing any signs of damage caused during transport?



NOTE!

The diaphragm at the process connection should not come in contact with sharp or hard objects.

Damage to the diaphragm may result in incorrect measurements or even to media leaking.

3.6 Storage

The devices must be stored in dry, clean conditions and protected against external, mechanical damage!

The admissible temperatures for storage can be found in the technical data for the devices:

- JUMO MAERA S25, type 401015, chapter 6.1 "JUMO MAERA S25 (type 401015)", Page 37
- JUMO MAERA S26, type 402090, chapter 6.2 "JUMO MAERA S26 (type 402090)", Page 40
- JUMO MAERA F27, type 404391, chapter 6.3 "JUMO MAERA F27 (type 404391)", Page 44
- JUMO MAERA S28, type 404392, chapter 6.4 "JUMO MAERA S28 (type 404392)", Page 47

4 Mounting

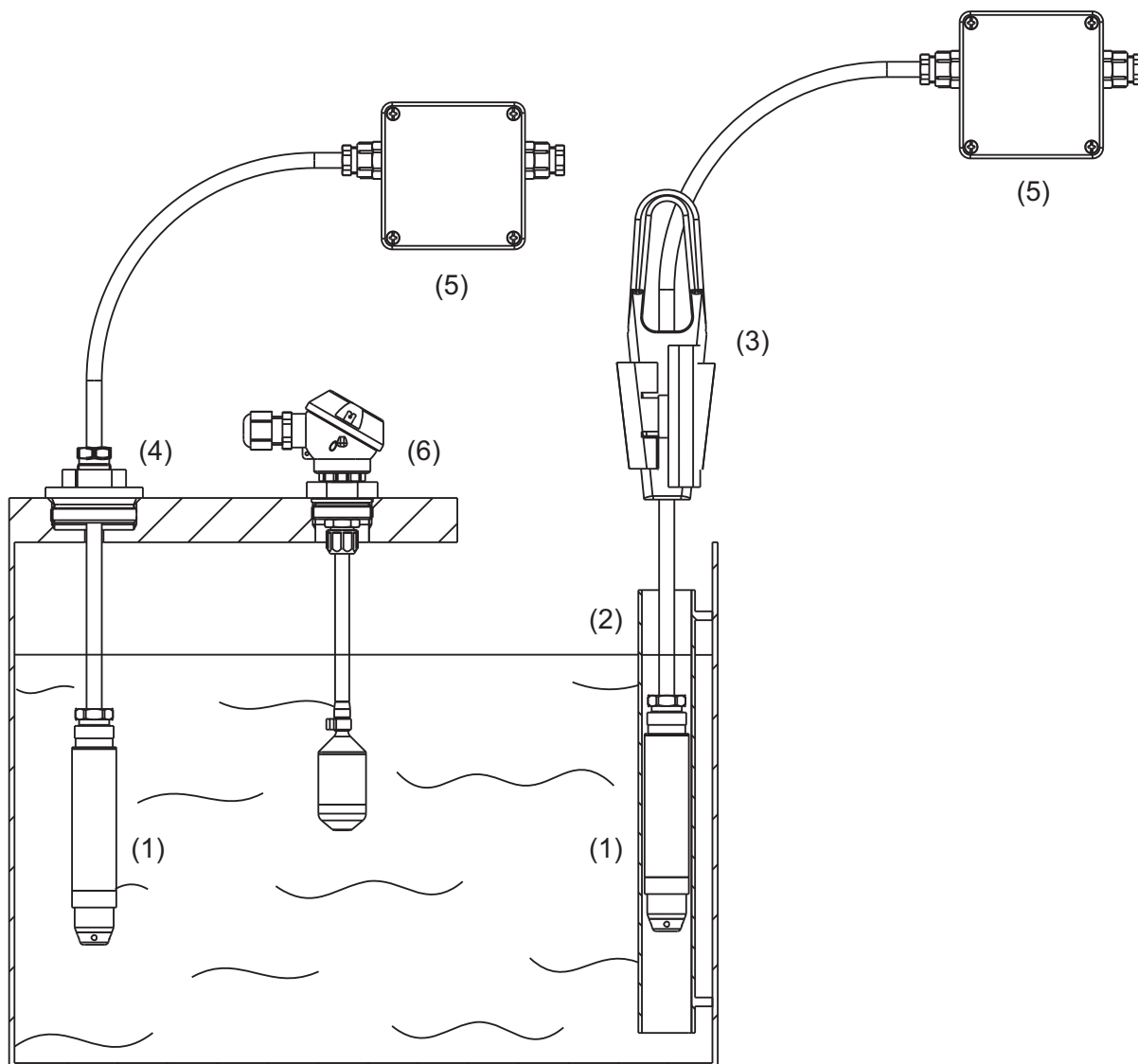

- (1) Level probe, hanging vertically in the medium
- (2) Guide tube for level probe
- (3) Cable clamp (accessories, part no. 00061389)
- (4) Sealing screw (accessories, part no. 00333329)
- (5) Terminal case with pressure compensation element (accessories, part no. 00061206)
- (6) Terminal head with pressure compensation element (accessories, part no. 00602743/00602744)



CAUTION!

Install the device in a currentless condition.



CAUTION!

For JUMO MAERA S25 (type 401015):
The non UV-resistant cable is not suitable for outdoor use.



NOTE!

The level probe must be grounded. To prevent **electrolysis**, the shielding of the level probe should be set to the same potential as the devices usually found in the medium, such as pumps and agitators.



NOTE!

The diaphragm at the process connection should not come in contact with sharp or hard objects.

Damage to the diaphragm may result in incorrect measurements or even to media leaking.



NOTE!

Cable assembly

The **special cable** for the level probe must be fitted such that the pressure compensation in the cable assembly is not crushed. The cable end must terminate in a dry room or in a suitable terminal case so that no moisture can penetrate in. In addition, the cable should not be routed through damp conditions. For variations in media, a guide tube should be used that prevents measuring errors in flow caused by sideways movement and by hitting the level probe against the walls of the container.

A terminal case with pressure compensation element is recommended (see chapter 3.3.3 "Terminal case with pressure compensation element", Page 20).

The terminal case should be mounted as close as possible to the surface of the medium whilst still outside the medium.

4 Mounting

4.1 Dimensions

4.1.1 JUMO MAERA S25 (type 401015)

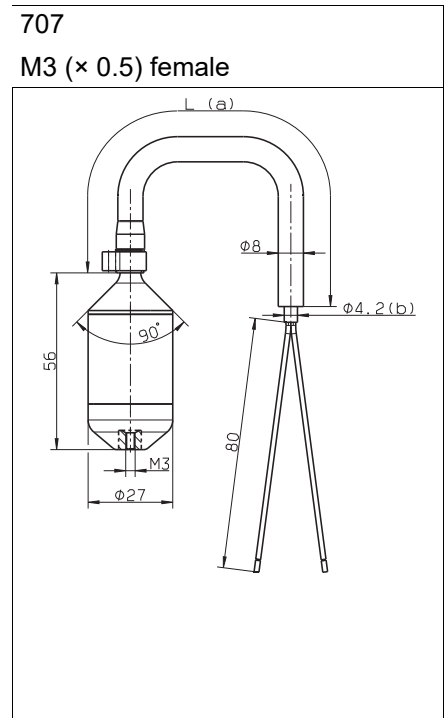
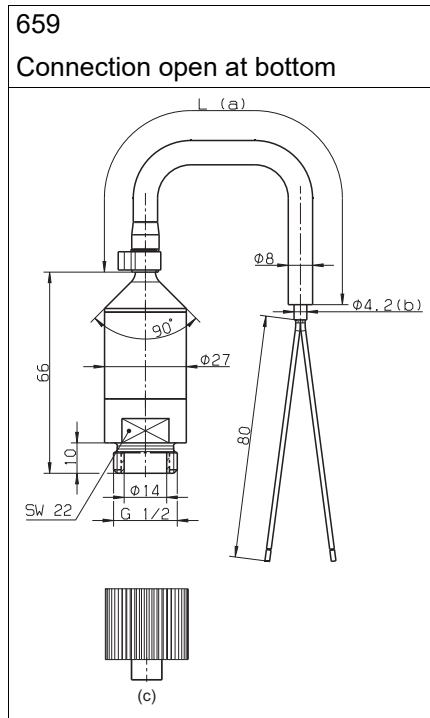
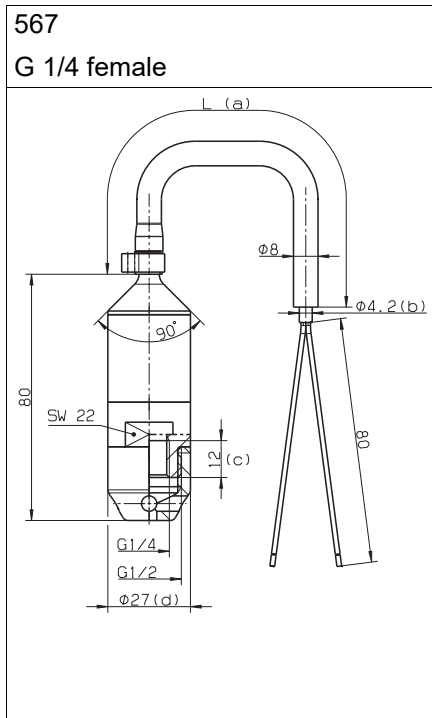

- L (a) Cable length according to customer preference
- (b) Ø 4.6 for three-wire output
- (c) Maximum screw-in depth
- (d) The protective cap has three bore holes (Ø 3) and protects the case against contact corrosion and the sensitive separating membrane.

- L (a) Cable length according to customer preference
- (b) Ø 4.6 for three-wire output
- (c) The protective cap is provided for transportation and has to be removed before implementing.

- L (a) Cable length according to customer preference
- (b) Ø 4.6 for three-wire output

For further information about the dimensions of the accessories, please see chapter 3.3 "Accessories", Page 19.

4.1.2 JUMO MAERA S26 (type 402090)

With mounted cage

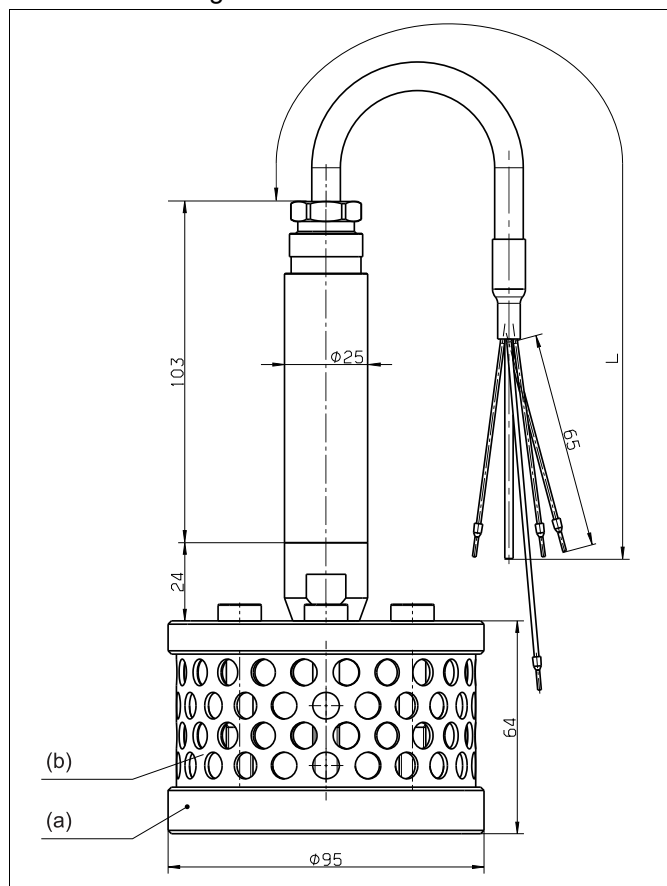

L Cable length according to customer preference

(a) Protective cage

(b) Perforated metal grid \varnothing 8 mm

The stainless steel version with mounted protective cage is designed for difficult level measurements where sludge, turbulence or currents may be present (e.g. pumping stations, wastewater lifting stations).

The additional weight reduces effects on the output signal with strongly moving media.

4 Mounting

567

G 1/4 inside

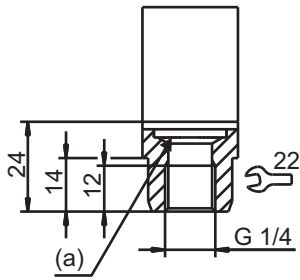

(a) Sensitive membrane

659

Connection open at the bottom

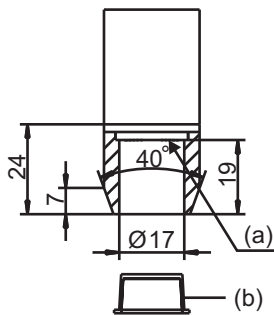

(a) Sensitive membrane

(b) Protective cap

658

Connection closed at the bottom

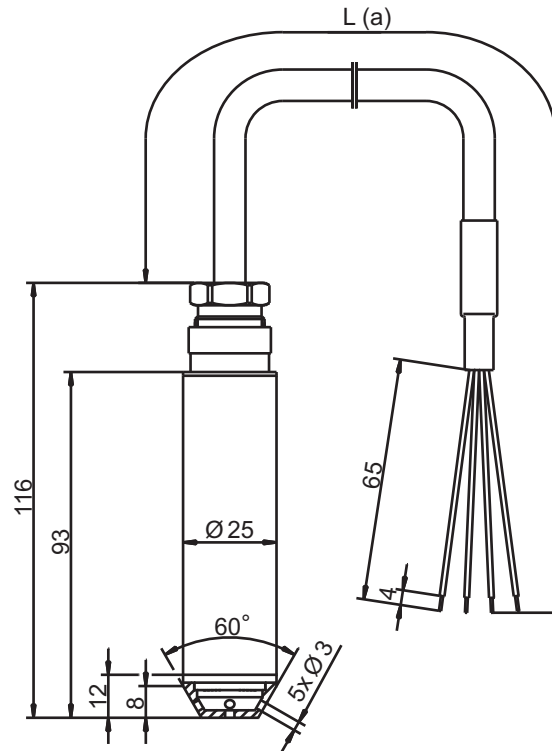

L (a) Cable length according to customer preference

For further information about the dimensions of the accessories, please see chapter 3.3 "Accessories", Page 19.

4.1.3 JUMO MAERA F27 (type 404391)

Type 404391/000-... or
type 404391/007-...
with process connection 659

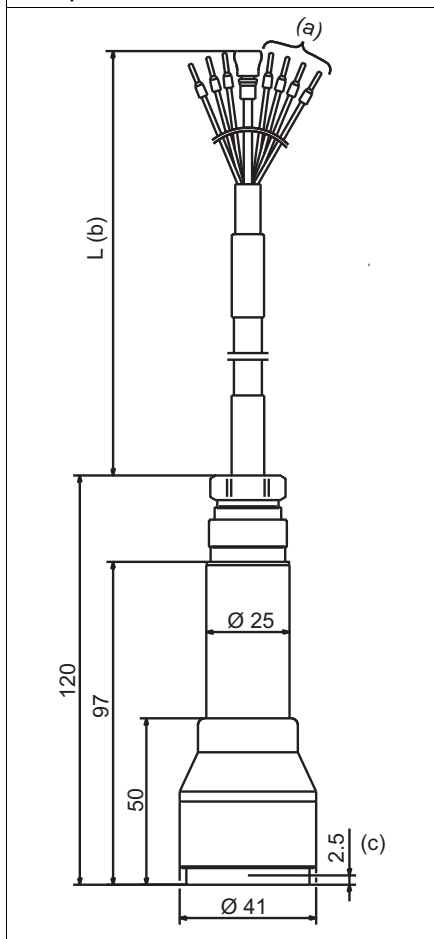

Type 404391/022-...
with process connection 568

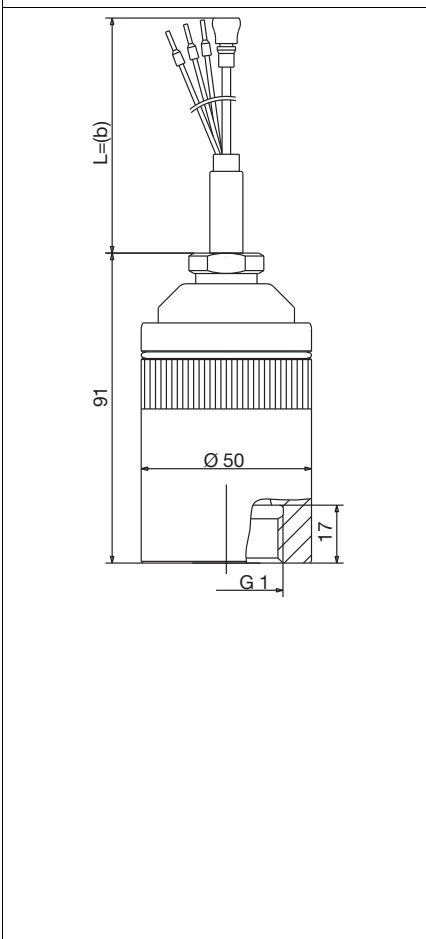

Type 404391/000-... or
type 404391/007-...
with process connection 658

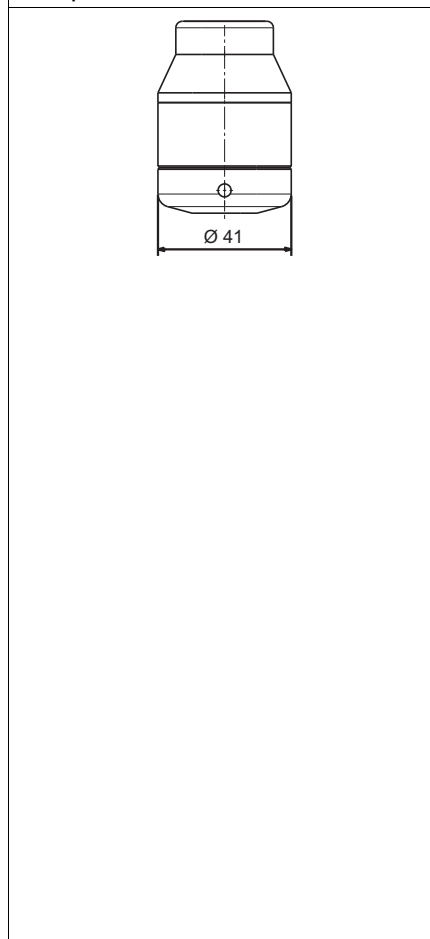

- (a) Only for version with integrated temperature probe Pt100
- (b) Cable length according to customer preference
- (c) Dimension up to surface sensor

- (b) Cable length according to customer preference

For further information about the dimensions of the accessories, please see chapter 3.3 "Accessories", Page 19.

4 Mounting

4.1.4 JUMO MAERA S28 (type 404392)

With mounted cage

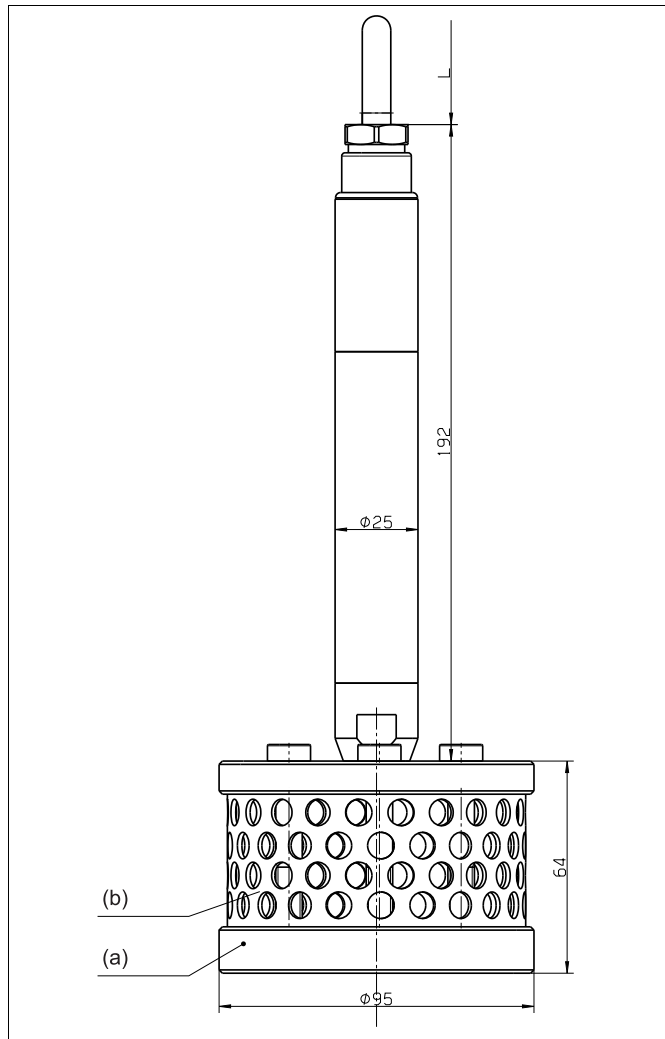

L Cable length according to customer preference

(a) Protective cage

(b) Perforated metal grid Ø 8 mm

The stainless steel version with mounted protective cage is designed for difficult level measurements where sludge, turbulence or currents may be present (e.g. pumping stations, wastewater lifting stations).

The additional weight reduces effects on the output signal with strongly moving media.

567
G 1/4 inside

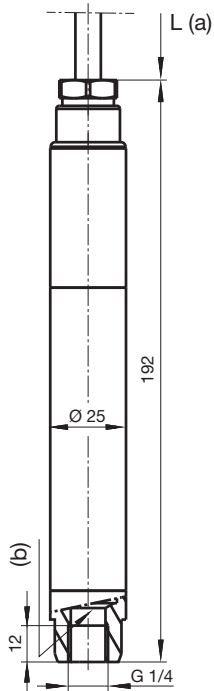

- (a) Cable length according to customer preference
- (b) Sensitive membrane

658
Connection closed at the bottom

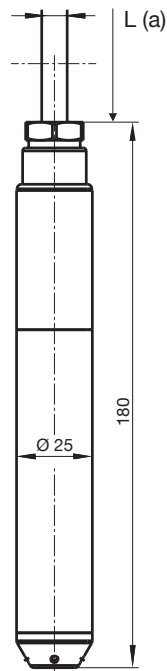

- (a) Cable length according to customer preference
- (b) Sensitive membrane

659
Connection open at the bottom

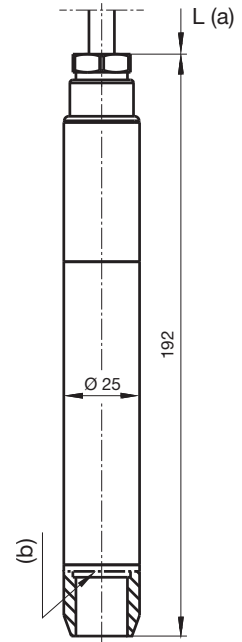

- (a) Cable length according to customer preference
- (b) Sensitive membrane

For further information about the dimensions of the accessories, please see chapter 3.3 "Accessories", Page 19.

5 Installation

5.1 Connection diagram



NOTE!

Level probes in free-field applications without integrated overvoltage protection must be protected against electrical discharge. In addition, it is recommended that external overvoltage protection is used upstream and downstream of the display or processing unit.

Connection example

Current output

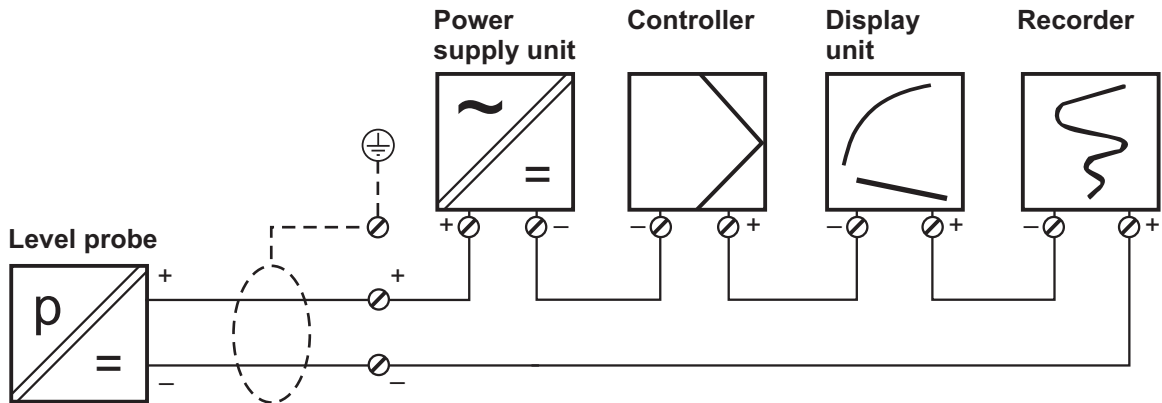

Voltage output

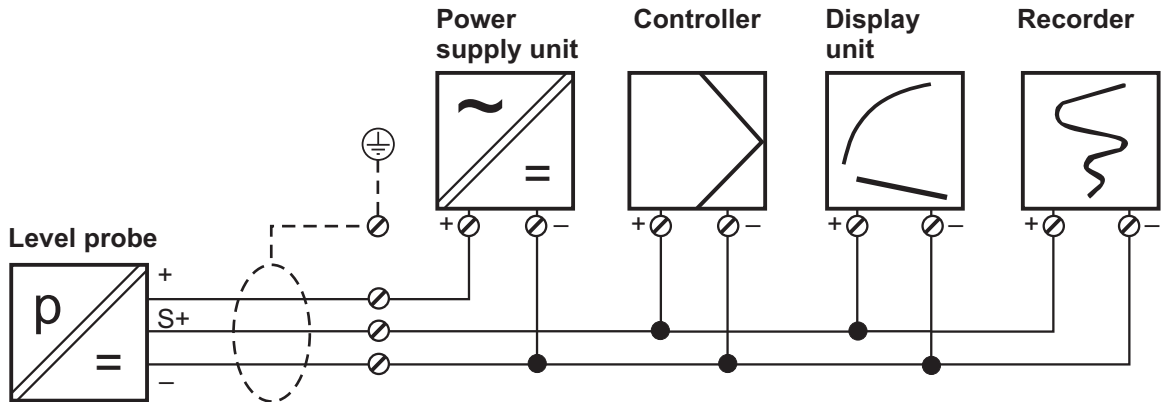

5.1.1 JUMO MAERA S25 (type 401015)

Connection		Terminal assignment
		
		Cable ^a
4 to 20 mA, two-wire (output 405)		
Voltage supply DC 10 to 30 V, Rated voltage supply DC 24 V	$U_{B/S}^{+b}$ 0 V/S-	White Brown
DC 0.5 to 4.5 V ratiometric (output 412)		
Voltage supply DC 5 V, Rated voltage supply DC 5 V	U_B^b 0 V/S- S+	White Brown Green
DC 0 to 10 V, three-wire (output 415)		
Voltage supply DC 11.5 to 30 V, Rated voltage supply DC 24 V	U_B^b 0 V/S- S+	White Brown Green
DC 1 to 5 V, three-wire (output 418) DC 1 to 6 V, three-wire (output 420)		
Voltage supply DC 10 to 30 V, Rated voltage supply DC 24 V	U_B^b 0 V/S- S+	White Brown Green

^a For cable specifications, see installation instructions B 401015.4, chapter 6 "Installation and mounting".

^b The voltage peaks must not exceed or fall below the specified voltage supply values!



NOTE!

Further information on electrical data ⇒ chapter 6.1.4 "Electrical data", Page 38, and electrical connection ⇒ chapter 6.1.5 "Electrical connection", Page 38



NOTE!

Further information for hose end piece ⇒ chapter 3.3.5 "Hose end piece", Page 21.

5 Installation

5.1.2 JUMO MAERA S26 (type 402090)

Connection		Terminal assignment
		
		Cable ^a
0 to 20 mA, three-wire (output 402)		
Voltage supply DC 11.5 to 30 V Rated voltage supply DC 24 V	U _B ^b 0 V/S- S+	White Gray Yellow
4 to 20 mA, two-wire (output 405)		
Voltage supply DC 10 to 30 V Rated voltage supply DC 24 V	U _{B/S+} 0 V/S-	White Gray
4 to 20 mA, two-wire (output 405 and EPR cable [electrical connection 26])		
Voltage supply DC 10 to 30 V Rated voltage supply DC 24 V	U _{B/S+} 0 V/S-	Brown Blue
4 to 20 mA, three-wire (output 406)		
Voltage supply DC 11.5 to 30 V Rated voltage supply DC 24 V	U _B 0 V/S- S+	White Gray Yellow
DC 0.5 to 4.5 V ratiometric (output 412)		
Voltage supply DC 5 V Rated voltage supply DC 5 V	U _B 0 V/S- S+	White Gray Yellow
DC 0 to 10 V, three-wire (output 415)		
Voltage supply DC 11.5 to 30 V Rated voltage supply DC 24 V	U _B 0 V/S- S+	White Gray Yellow
DC 1 to 5 V, three-wire (output 418) DC 1 to 6 V, three-wire (output 420)		
Voltage supply DC 10 to 30 V Rated voltage supply DC 24 V	U _B 0 V/S- S+	White Gray Yellow
Shielding		
Caution: Ground the device! Ground all connected devices (such as pumps and valves) to the same potential!		Black

^a For cable specifications, see installation instructions B 401015.4, chapter 6 "Installation and mounting".

^b The voltage peaks must not exceed or fall below the specified voltage supply values!



NOTE!

Further information on electrical data ⇒ chapter 6.2.4 "Electrical data", Page 41, and electrical connection ⇒ chapter 6.2.5 "Electrical connection", Page 42

5.1.3 JUMO MAERA F27 (type 404391)

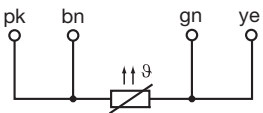
Connection		Terminal assignment
		
		Cable ^a
4 to 20 mA, two-wire (output 405)		
Voltage supply DC 12 to 30 V Rated voltage supply DC 24 V	$U_{B/S+}$ ^b 0 V/S-	White Gray
DC 0.5 to 4.5 V, ratiometric (output 412)		
Voltage supply DC 5 V Rated voltage supply DC 5 V	U_B 0 V/S- S+	White Gray Yellow
Shielding		
Caution: Ground the device! Ground all connected devices (such as pumps and valves) to the same potential!		Black
Integrated temperature probe (with basic type extension 007)^c		
		Pink (pk) Brown (bn) Green (gn) Yellow (ye)

^a For cable specifications, see installation instructions B 401015.4, chapter 6 "Installation and mounting".

^b The voltage peaks must not exceed or fall below the specified voltage supply value!

^c Level probes in free-field applications without integrated overvoltage protection must be protected against electrical discharge. In addition, it is recommended that external overvoltage protection is used upstream and downstream of the display or processing unit.



NOTE!

Further information on electrical data ⇒ chapter 6.3.4 "Electrical data", Page 45, and electrical connection ⇒ chapter 6.3.5 "Electrical connection", Page 45

5 Installation

5.1.4 JUMO MAERA S28 (type 404392)

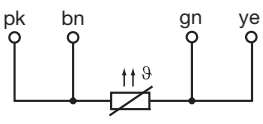
Connection		Terminal assignment
		
		Cable ^a
4 to 20 mA, two-wire (output 405 and basic type 404392/000)		
Voltage supply DC 10 to 30 V Rated voltage supply DC 24 V	U _B /S+ ^b 0 V/S-	White Gray
Shielding		
Caution: Ground the device! Ground all connected devices (such as pumps and valves) to the same potential!		Black
4 to 20 mA, two-wire (output 405 and basic type 404392/025)		
Voltage supply DC 10 to 30 V Rated voltage supply DC 24 V	U _B /S+ ^b 0 V/S-	Brown Blue
Integrated temperature probe (with basic type extension 007)		
		Pink (pk) Brown (bn) Green (gn) Yellow (ye)

^a For cable specifications, see installation instructions B 401015.4, chapter 6 "Installation and mounting".

^b The voltage peaks must not exceed or fall below the specified voltage supply values!



NOTE!

Further information on electrical data ⇒ chapter 6.4.4 "Electrical data", Page 48, and electrical connection ⇒ chapter 6.4.5 "Electrical connection", Page 48

5.2 Operation



CAUTION!

Generally speaking, the technical data in the installation instructions must be observed. During operation of the level probe, it should be ensured in particular that the admissible medium temperature is neither too low nor too high, and that the level probe is not frozen in the medium. In addition, the admissible excess pressure must not be exceeded.



DANGER!

Potentially explosive area
The devices in these installation instructions are not intended for use in potentially explosive areas.



NOTE!

Constantly changing medium temperatures may lead to a zero offset, extreme variations in temperature, or even to device failure.

6.1 JUMO MAERA S25 (type 401015)

6.1.1 General Information

Reference conditions	DIN 16086 and DIN EN 60770
Measuring principle	Piezoresistive sensor with stainless steel separating membrane
Pressure transfer means	Synthetic oil
Admissible load changes	> 10 million, 0 to 100 % measuring range
Mounting position	Vertical/hanging from the cable

6.1.2 Measuring range and accuracy

Measuring range bar	Linearity ^a % MSP ^e	Accuracy at		Long-term stability ^b % MSP per year	Overload capability bar	Burst pressure bar
		20 °C ^c % MSP	0 to 50 °C ^d % MSP			
0 to 0.25 bar relative pressure	0.3	0.5	1	≤ 0.3	0.75	1
0 to 0.4 bar relative pressure	0.3	0.5	1		1.2	1.6
0 to 0.6 bar relative pressure	0.3	0.5	1		1.8	2.4
0 to 1 bar relative pressure	0.3	0.5	1		3	4

^a Linearity according to limit point setting

^b Reference conditions EN 61298-1

^c Includes: linearity, hysteresis, repeatability, deviation from measuring range start (offset), and measuring range end

^d Includes: linearity, hysteresis, repeatability, deviation from measuring range start (offset) and measuring range end, thermal influences on measuring range start (offset), and measuring span

^e MSP = measuring span

6.1.3 Output

Analog output	
Current	
Output 405	4 to 20 mA, two-wire
Voltage	
Output 412	DC 0.5 to 4.5 V, three-wire, ratiometric 10 to 90 % of the voltage supply
Output 415	DC 0 to 10 V, three-wire
Output 418	DC 1 to 5 V, three-wire
Output 420	DC 1 to 6 V, three-wire
Step response T ₉₀	≤ 10 ms
Burden	
Current	
4 to 20 mA, two-wire	$R_L \leq (U_B - 10 \text{ V}) \div 0.02 \text{ A} (\Omega)$
Voltage	
DC 0.5 to 4.5 V, three-wire	$R_L \geq 20 \text{ k}\Omega$
DC 0 to 10 V, three-wire	$R_L \geq 10 \text{ k}\Omega$
DC 1 to 5 V, three-wire	$R_L \geq 10 \text{ k}\Omega$
DC 1 to 6 V, three-wire	$R_L \geq 10 \text{ k}\Omega$

6 Technical data

6.1.4 Electrical data

Voltage supply U_B^a 4 to 20 mA, two-wire DC 0.5 to 4.5 V, three-wire DC 0 to 10 V, three-wire DC 1 to 5 V, three-wire DC 1 to 6 V, three-wire Nominal voltage	DC 10 to 30 V DC 5 V DC 11.5 to 30 V DC 10 to 30 V DC 10 to 30 V DC 24 V
Reverse voltage protection	Yes (except DC 0.5 to 4.5 V, three-wire)
Max. current consumption	25 mA
Electrical circuit Requirements	SELV The device must be equipped with an electrical circuit that meets the requirements of EN 61010-1 with regard to "Limited-energy circuits".

^a Residual ripple: The voltage peaks must not exceed or fall below the specified voltage supply values!

6.1.5 Electrical connection

For this construction, a stranded PVC cable is encased in an application-oriented protective hose made from either PE or PA.

To prevent moisture penetrating into the protective hose, in this case the pressure equalization hose, the delivery includes a hose end piece with the fitting materials.

Outer diameter	8 mm
Bending radius	Approx. 120 mm It is vital to take into account that if the protective hose is kinked or pinched, this will prevent ambient pressure compensation.
Admissible medium temperatures	0 to 50 °C (depending on the medium and the level probe)
Yield stress PE protective hose PA protective hose	10 M Pa 22 M Pa

6.1.6 Mechanical features

Ensure the medium durability of the material!

Materials Process connection Measuring membranes Case Protective cap Protective hose	Stainless steel 316 L (G 1/4 inside), Stainless steel 316 Ti (M3 (× 0.5) inside) Stainless steel 316 L Stainless steel 304 Hard PVC PE (natural: non UV resistant), PA (natural: non UV resistant; black: UV resistant) The non UV-resistant cable is not suitable for outdoor use.
Weight	90 g (without cable)
Diameter	25 mm

6.1.7 Environmental influences

Admissible temperatures	
Medium	0 to 50 °C The device must not freeze in the medium! A restriction may be required depending on the medium.
Storage	-20 to +80 °C, dry
Electromagnetic compatibility (EC)	According to DIN EN 61326-1, DIN EN 61326-2-3
Interference emission	Class B ^a
Interference immunity	Industrial requirements
Protection type	IP68, according to DIN EN 60529, submersible to 20 m

^a The product is suitable for industrial use as well as for households and small businesses.

6 Technical data

6.2 JUMO MAERA S26 (type 402090)

6.2.1 General Information

Reference conditions	DIN 16086 and DIN EN 60770
Measuring principle	Piezoresistive sensor with stainless steel separating membrane
Pressure transfer means	Synthetic oil
Admissible load changes	> 10 million, 0 to 100 % measuring range
Mounting position	Vertical/hanging from the cable

6.2.2 Measuring range and accuracy

Measuring range bar	Linearity ^a % MSP ^e	Accuracy at		Long-term stability ^b % MSP per year	Overload capacity bar	Burst pressure bar
		20 °C ^c % MSP	0 to 50 °C ^d % MSP			
0 to 0.25 bar relative pressure	0.3	0.5	1.6	≤ 0.3	0.75	1
0 to 0.4 bar relative pressure	0.3	0.5	1.6		1.2	1.6
0 to 0.6 bar relative pressure	0.3	0.5	1.3		1.8	2.4
0 to 1 bar relative pressure	0.3	0.5	1.1		3	4
0 to 1.6 bar relative pressure	0.3	0.5	1.1		4.8	6,4
0 to 2.5 bar relative pressure	0.3	0.5	1.1		7.5	10
0 to 4 bar relative pressure	0.2	0.3	0.8		12	16
0 to 6 bar relative pressure	0.2	0.3	0.8		18	24
0 to 10 bar relative pressure	0.2	0.3	0.8		30	40

^a Linearity according to limit point setting

^b Reference conditions EN 61298-1

^c Includes: linearity, hysteresis, repeatability, deviation from measuring range start (offset), and measuring range end

^d Includes: linearity, hysteresis, repeatability, deviation from measuring range start (offset) and measuring range end, thermal influences on measuring range start (offset), and measuring span

^e MSP = measuring span

6.2.3 Output

Analog output Current Output 402 Output 405 Output 406 Voltage Output 412 Output 415 Output 418 Output 420	0 to 20 mA, three-wire 4 to 20 mA, two-wire 4 to 20 mA, three-wire DC 0.5 to 4.5 V, three-wire, ratiometric 10 to 90 % of the voltage supply DC 0 to 10 V, three-wire DC 1 to 5 V, three-wire DC 1 to 6 V, three-wire
Step response T_{90}	≤ 10 ms
Burden Current 0 to 20 mA, three-wire 4 to 20 mA, two-wire 4 to 20 mA, three-wire Voltage DC 0.5 to 4.5 V, three-wire DC 0 to 10 V, three-wire DC 1 to 5 V, three-wire DC 1 to 6 V, three-wire	$R_L \leq (U_B - 12 \text{ V}) \div 0.02 \text{ A} (\Omega)$ $R_L \leq (U_B - 10 \text{ V}) \div 0.02 \text{ A} (\Omega)$ $R_L \leq (U_B - 12 \text{ V}) \div 0.02 \text{ A} (\Omega)$ $R_L \geq 50 \text{ k}\Omega$ $R_L \geq 10 \text{ k}\Omega$ $R_L \geq 10 \text{ k}\Omega$ $R_L \geq 10 \text{ k}\Omega$

6.2.4 Electrical data

Voltage Supply U_B^a 0 mA to 20 mA, three-wire 4 mA to 20 mA, two-wire 4 mA to 20 mA, three-wire DC 0.5 V to 4.5 V, three-wire DC 0 V to 10 V, three-wire DC 1 V to 5 V, three-wire DC 1 V to 6 V, three-wire Nominal voltage	DC 11.5 V to 30 V DC 10 V to 30 V DC 11.5 V to 30 V DC 5 V DC 11.5 V to 30 V DC 10 V to 30 V DC 10 V to 30 V DC 24 V
Reverse voltage protection	Yes (except DC 0.5 to 4.5 V, three-wire)
Max. current consumption	≤ 25 mA
Electrical circuit Requirements	SELV The device must be equipped with an electrical circuit that meets the requirements of EN 61010-1 with regard to "Limited-energy circuits".

^a Residual ripple: The voltage peaks must not exceed or fall below the specified voltage supply values!

6 Technical data

6.2.5 Electrical connection

for level probe with EPR cable (electrical connection 26)

2-core cable without pressure compensation with ferrules

Outer diameter	Approx. 8.3 mm
Conductor cross section	1 mm ²
Bending radius	
Moving	40 mm
Fixed	30 mm
Tensile force	Up to 400 N
Admissible medium temperatures	-40 to +60 °C

6.2.6 Mechanical features

Ensure the medium durability of the material!

Materials	
Process connection	Stainless steel 316 Ti
Measuring membrane	Stainless steel 316 L
Case	Stainless steel 316 Ti
Sealing cone	FPM, EPDM
Outer sheath	Basic type: PE (black), PUR (pebble gray), FEP (black) Basic type with submersible motor cable: EPR (blue)
Pressure compensation hose	PA
Weight	200 g (without cable) plus 1500 g for process connection with mounted protective cage (without cable)
PE cable	Approx. 63 g/m
PUR cable	Approx. 115 g/m
FEP cable	Approx. 90 g/m
EPR cable	Approx. 92 g/m
UV resistance	
PE, PUR cable	According to VDE 0207, test method EN 60811 part 2-1, section 8
FEP cable	According to DIN ISO 4892-2
Diameter	25 mm

6.2.7 Environmental influences

Inadmissible temperatures Medium, environment	0 to 50 °C The device must not freeze in the medium! A restriction may be required depending on the medium.
Storage	-20 to +80 °C, dry
Electromagnetic compatibility (EC) Interference emission Interference immunity	Class B ^a , according to EN 61326-1 Industrial requirements, according to EN 61326-2-3
Protection type	IP68, according to EN 60529, submersible to 60 m

^a The product is suitable for industrial use as well as for households and small businesses.

6.2.8 Approvals and approval marks

CSA Testing agency Certificates/certification numbers Inspection basis Valid for	CSA Group 70209471 CAN/CSA-C22.2 No. 61010-1-12, UL Std. No. 61010-1 (3rd Edition) Extra code 067
ACS Testing agency Certificates/certification numbers Inspection basis Valid for	Eurofins Expertises Environnementales 16 ACC NY 235 DGS/SD7A No 2002-571 Extra code 881

6 Technical data

6.3 JUMO MAERA F27 (type 404391)

6.3.1 General Information

Reference conditions	DIN 16086 and DIN EN 60770
Sensor system	Capacitive ceramic sensor
Mounting position	Vertical/hanging from the cable

6.3.2 Measuring range and accuracy

Case: stainless steel (standard)

Measuring range bar	Linearity ^a % MSP ^e	Accuracy at			Long term stability ^b % MSP per year	Overload capability bar	Burst pressure bar
		20 °C ^c % MSP	0 to 40 °C ^d % MSP	-20 to +60 °C ^d % MSP			
0 to 0.05 bar relative pressure	0.2	0.4	0.9	1.3	≤ 0.2	-0.3/4	150
0 to 0.1 bar relative pressure	0.2	0.4	0.9	1.3		-0.3/4	
0 to 0.16 bar relative pressure	0.2	0.4	0.9	1.3		5	
0 to 0.25 bar relative pressure	0.2	0.4	0.9	1.3		6	
0 to 0.4 bar relative pressure	0.2	0.4	0.9	1.3		6	
0 to 0.6 bar relative pressure	0.2	0.4	0.9	1.3		10	
0 to 1 bar relative pressure	0.2	0.4	0.4	0.6		10	
0 to 1.6 bar relative pressure	0.2	0.4	0.4	0.6		10	

Case: PTFE (basic type extension 022)

0 to 0.05 bar relative pressure	0.2	0.4	0.9	1.3	≤ 0.2	-0.3/2	150
0 to 0.1 bar relative pressure	0.2	0.4	0.9	1.3		-0.3/2	
0 to 0.16 bar relative pressure	0.2	0.4	0.9	1.3		2	
0 to 0.25 bar relative pressure	0.2	0.4	0.9	1.3		2	
0 to 0.4 bar relative pressure	0.2	0.4	0.9	1.3		2	
0 to 0.6 bar relative pressure	0.2	0.4	0.9	1.3		2	
0 to 1 bar relative pressure	0.2	0.4	0.4	0.6		2	
0 to 1.6 bar relative pressure	0.2	0.4	0.4	0.6		2	

^a Linearity according to limit point setting

^b Reference conditions EN 61298-1

^c Includes: linearity, hysteresis, repeatability, deviation of measuring range initial value and measuring range end value

^d Includes: linearity, hysteresis, repeatability, deviation of measuring range initial value and measuring range end value, thermal effect on measuring range start and measuring span

^e MSP = measuring span

6.3.3 Output

Analog output	
Current	4 to 20 mA, two-wire
Voltage	DC 0.5 to 4.5 V, three-wire, ratiometric 10 to 90 % of the voltage supply
Step response T_{90}	≤ 10 ms
Burden	
Current	
4 to 20 mA, two-wire	$R_L \leq (U_B - 12 \text{ V}) \div 0.02 \text{ A } (\Omega)$
Voltage	
DC 0.5 to 4.5 V, three-wire	$R_L \geq 10 \text{ k}\Omega$

6.3.4 Electrical data

Voltage supply U_B^a	
4 to 20 mA, two-wire	DC 12 to 30 V
DC 0.5 to 4.5 V, three-wire	DC 5 V
Nominal voltage	DC 24 V
Reverse voltage protection	Yes (except DC 0.5 to 4.5 V, three-wire)
Max. current consumption	For DC 24 V ≤ 25 mA For DC 5 V ≤ 2 mA
Electrical circuit	SELV
Requirements	The device must be equipped with an electrical circuit that meets the requirements of EN 61010-1 with regard to "Limited-energy circuits".

^a Residual ripple: the voltage peaks must not exceed or fall below the specified voltage supply values!

6.3.5 Electrical connection

6-wire, shielded cable with integrated pressure compensation hose, AWG 24 with ferrules

Outer diameter	Approx. 8.4 mm
Conductor cross section	0.25 mm ²
Bending radius	
Moving	160 mm
Fixed	120 mm
	It is vital to take into account that if the protective hose is kinked or pinched, this will prevent ambient pressure compensation.
Tensile force	Up to 400 N
Admissible medium temperatures	-40 to +70 °C (depending on the medium)

6 Technical data

6.3.6 Mechanical features

Ensure the medium durability of the material!

Materials	
Process connection	Stainless steel 316 Ti
Sensor	Ceramic Al ₂ O ₃ (99.9 %)
Case, standard	Stainless steel 316 Ti
Case made of plastic	PTFE
Seals	FPM (standard), EPDM
Protective cap	PA
Outer sheath	PE (black), PUR (pepple gray), FEP (black)
Pressure compensation hose	PA
Weight	200 g (without cable)
PE cable	Approx. 63 g/m, 115 g/m with additional temperature sensor (extra code 007)
PUR cable	Approx. 115 g/m
FEP cable	Approx. 90 g/m
UV resistance	
PE, PUR cable	according to VDE 0207, test method EN 60811 part 2-1, section 8
FEP cable	cable according to DIN ISO 4892-2
Diameter	
Stainless steel version	41 mm
PTFE version	50 mm

6.3.7 Environmental influences

Admissible temperatures	
Medium, environment	-20 to +60 °C The device must not freeze in the medium! A restriction may be required depending on the medium.
With case made of plastic	0 to 40 °C The device must not freeze in the medium! A restriction may be required depending on the medium.
Storage	-20 to +100 °C, dry
Electromagnetic compatibility (EC)	According to DIN EN 61326-1, DIN EN 61326-2-3
Interference emission	Class B ^a
Interference immunity	Industrial requirements
Overvoltage protection	Integrated overvoltage protection, according to DIN EN 61000-4-5
Rated leakage current	1 kA
Protection type	IP68, according to DIN EN 60529, submersible to 16 m

^a The product is suitable for industrial use as well as for households and small businesses.

6.4 JUMO MAERA S28 (type 404392)

6.4.1 General Information

Reference conditions	DIN 16086 and DIN EN 60770
Measuring principle	Piezoresistive sensor with stainless steel separating membrane
Pressure transfer means	Synthetic oil
Admissible load changes	> 10 million, 0 to 100 % measuring range
Mounting position	Vertical/hanging from the cable

6.4.2 Measuring range and accuracy

Measuring range bar	Linearity ^a % MSP ^e	Accuracy at		Long-term stability ^b % MSP per year	Overload capability bar	Burst pressure bar
		20 °C ^c % MSP	0 to 50 °C ^d % MSP			
0 to 0.25 bar relative pressure	0.3	0.5	1.6	≤ 0.2	0.75	1
0 to 0.4 bar relative pressure	0.3	0.5	1.6		1.2	1.6
0 to 0.6 bar relative pressure	0.3	0.5	1.3		1.8	2.4
0 to 1 bar relative pressure	0.3	0.5	1.1		3	4
0 to 1.6 bar relative pressure	0.3	0.5	1.1		4.8	6.4
0 to 2.5 bar relative pressure	0.3	0.5	1.1		7.5	10
0 to 4 bar relative pressure	0.2	0.3	0.8		12	16
0 to 6 bar relative pressure	0.2	0.3	0.8		18	24
0 to 10 bar relative pressure	0.2	0.3	0.8		30	40

^a Linearity according to limit point setting

^b Reference conditions EN 61298-1

^c Includes: linearity, hysteresis, repeatability, deviation of measuring range initial value and measuring range end value

^d Includes: linearity, hysteresis, repeatability, deviation of measuring range initial value and measuring range end value, thermal effect on measuring range start and measuring span

^e MSP = measuring span

6.4.3 Output

Analog output Current	4 to 20 mA, two-wire
Step response T ₉₀	≤ 10 ms
Burden Current	$R_L \leq (U_B - 10 \text{ V}) \div 0.02 \text{ A} (\Omega)$

6 Technical data

6.4.4 Electrical data

Voltage supply U_B^a Nominal voltage	DC 10 V to 30 V DC 24 V
Reverse voltage protection	Yes
Max. current consumption	30 mA
Electrical circuit Requirements	SELV The device must be equipped with an electrical circuit that meets the requirements of EN 61010-1 with regard to "Limited-energy circuits".

^a Residual ripple: the voltage peaks must not exceed or fall below the specified voltage supply values!

6.4.5 Electrical connection

for level probe (basic type 404392/000)

6-core, shielded cable with integrated pressure compensation hose, AWG 24 with ferrules

Outer diameter	Approx. 8.4 mm
Conductor cross section	0.25 mm ²
Bending radius Moving Fixed	160 mm 120 mm It is vital to take into account that if the protective hose is kinked or pinched, this will prevent ambient pressure compensation.
Tensile force	Up to 400 N
Admissible medium temperatures	-40 to +70 °C (depending on the medium)

for level probe in the deep well version (basic type 404392/025)

2-core cable without pressure compensation with ferrules

Outer diameter	Approx. 8.3 mm
Conductor cross section	1 mm ²
Bending radius Moving Fixed	40 mm 30 mm
Tensile force	Up to 400 N
Admissible medium temperatures	-40 to +60 °C

6.4.6 Mechanical features

Ensure the medium durability of the materials!

Materials	
Process connection	Stainless steel 316 Ti
Measuring membrane	Stainless steel 316 L
Case	Stainless steel 316 Ti
Seals	FPM, EPDM
Outer sheath	Basic type 404393/000: PE (black), PUR (pepple gray), FEP (black) Basic type 404393/025: EPR (blue)
Pressure compensation hose	Basic type 404393/000: PA
Weight	400 g (without cable) plus 1500 g for process connection with mounted protective cage (without cable)
PE cable	Approx. 63 g/m, 115 g/m with additional temperature sensor (extra code 007)
PUR cable	Approx. 115 g/m
FEP cable	Approx. 90 g/m
EPR cable	Approx. 92 g/m
UV resistance	
PE, PUR cable	According to VDE 0207, test method EN 60811 part 2-1, section 8
FEP cable	According to DIN ISO 4892-2
Diameter	25 mm

6.4.7 Environmental influences

Admissible temperatures	
Medium, environment	0 to 50 °C The device must not freeze in the medium! A restriction may be required depending on the medium.
Storage	-20 to +80 °C, dry
Electromagnetic compatibility (EC)	
Interference emission	Class B ^a , according to EN 61326-2-3
Interference immunity	Industrial requirements, according to EN 61326-1
Overvoltage protection	Integrated overvoltage protection according to 61000-4-5
Rated leakage current	1 kA
Protection type	IP68, according to EN 60529, submersible to 100 m

^a The product is suitable for industrial use as well as for households and small businesses.

6.4.8 Approvals and approval marks

ACS	
Testing agency	Eurofins Expertises Environnementales
Certificates/certification numbers	16 ACC NY 235
Inspection basis	DGS/SD7A No 2002-571
Valid for	Extra code 881

7 Malfunctions/faults



DANGER!

Medium residuals may damage humans, the environment and equipment!



CAUTION!

Irreparable damage occurs if the membrane comes into contact with sharp or hard objects!

Type of fault	Possible causes	Measures
No measuring and/or output signal	Voltage supply is too low	Check the voltage supply, see chapter 6 "Technical data", Page 37
	Open circuit, incorrect connection	Check the connecting cable, see chapter 6 "Technical data", Page 37
	Mechanical, thermal or chemical damage	Send the device with the fault description and declaration of decontamination to the suppliers, see chapter 9.3 "Returns", Page 64
Constant output signal even with changes in pressure	Measuring system destroyed by excess pressure	Send the device with the fault description and declaration of decontamination to the suppliers, see chapter 9.3 "Returns", Page 64
	Output signal is distorted as a result of excess pressure due to current limiting	Check the voltage supply, see chapter 6 "Technical data", Page 37
Output signal is too high	Measuring range selected is too small	Send the device with the fault description and declaration of decontamination to the suppliers, see chapter 9.3 "Returns", Page 64
	Electrics are faulty	
	Voltage supply is too high	
Output signal is too low	For current output signal: Burden is too high	Change the burden, see chapter 6 "Technical data", Page 37
	For voltage output signal: Burden too low	
	Voltage supply is too low	Change the voltage supply, see chapter 6 "Technical data", Page 37
	Membrane damaged by mechanical influences, an aggressive medium, or corrosion, for example	Send the device with the fault description and declaration of decontamination to the suppliers, see chapter 9.3 "Returns", Page 64

7 Malfunctions/faults

Type of fault	Possible causes	Measures
Varying zero point signal	Medium and/or ambient temperature is too high or too low	Send the device with the fault description and declaration of decontamination to the suppliers, see chapter 9.3 "Returns", Page 64
	Membrane contaminated	Carefully clean the membrane using a soft brush or sponge with a non-aggressive cleaning agent, for example, see chapter 9.2 "Cleaning", Page 64 Membrane must not be damaged!
	Membrane damaged by mechanical influences, an aggressive medium, or corrosion, for example	Send the device with the fault description and declaration of decontamination to the suppliers, see chapter 9.3 "Returns", Page 64
	Moisture entered the device	Send the device with the fault description and declaration of decontamination to the suppliers, see chapter 9.3 "Returns", Page 64
Characteristic line of the output signal is not linear	Device altered by inadmissible operating conditions (such as excess pressure)	Send the device with the fault description and declaration of decontamination to the suppliers, see chapter 9.3 "Returns", Page 64

8 Declaration of conformity

JUMO MAERA S25 (Type 401015)

JUMO GmbH & Co. KG

Moritz-Juchheim-Straße 1
36039 Fulda, Germany

Tel.: +49 661 6003-0
Fax: +49 661 6003-500

E-Mail: mail@jumo.net
Internet: www.jumo.net



More than **sensors + automation**

EU-Konformitätserklärung

EU declaration of conformity / Déclaration UE de conformité

Dokument-Nr. <i>Document No. / Document n°.</i>	CE 674	
Hersteller <i>Manufacturer / Etabli par</i>	JUMO GmbH & Co. KG	
Anschrift <i>Address / Adresse</i>	Moritz-Juchheim-Straße 1, 36039 Fulda, Germany	
Produkt <i>Product / Produit</i>		
Name <i>Name / Nom</i>	Typ <i>Type / Type</i>	Typenblatt-Nr. <i>Data sheet no. / N° Document d'identification</i>
JUMO MAERA S25	401015	401015

Wir erklären in alleiniger Verantwortung, dass das bezeichnete Produkt die Anforderungen der Europäischen Richtlinien erfüllt.

We hereby declare in sole responsibility that the designated product fulfills the requirements of the European Directives.

Nous déclarons sous notre seule responsabilité que le produit remplit les Directives Européennes.

Richtlinie 1

Directive / Directive

Name EMC
Name / Nom

Fundstelle 2014/30/EU
Reference / Référence

Bemerkung
Comment / Remarque

Datum der Erstanbringung des CE-Zeichens auf dem Produkt 2011

*Date of first application of the CE mark to the product / Date
de 1ère application du sigle sur le produit*

Dokument-Nr.
Document No. / Document n°.

CE 674

EU-Konformitätserklärung

Seite: 1 von 3

8 Declaration of conformity

JUMO GmbH & Co. KG

Moritz-Juchheim-Straße 1
36039 Fulda, Germany

Tel.: +49 661 6003-0
Fax: +49 661 6003-500

E-Mail: mail@jumo.net
Internet: www.jumo.net



More than sensors + automation

Angewendete Normen/Spezifikationen

Standards/Specifications applied / Normes/Spécifications appliquées

Fundstelle

Reference / Référence

EN 61326-1

EN 61326-2-3

Ausgabe

Edition / Édition

2013

2013

Bemerkung

Comment / Remarque

Gültig für Typ

Valid for Type / Valable pour le type

401015/...

Richtlinie 2

Directive / Directive

Name

Name / Nom

RoHS

Fundstelle

Reference / Référence

2011/65/EU

Bemerkung

Comment / Remarque

Datum der Erstanbringung des CE-Zeichens 2017

auf dem Produkt

Date of first application of the CE mark to the product / Date

de 1ère application du sigle sur le produit

Angewendete Normen/Spezifikationen

Standards/Specifications applied / Normes/Spécifications appliquées

Fundstelle

Reference / Référence

VDK Umweltrelevante Aspekte V1

bei der Produktentwicklung und

-gestaltung

Ausgabe

Edition / Édition

Bemerkung

Comment / Remarque

Gültig für Typ

Valid for Type / Valable pour le type

401015/...

Dokument-Nr.

Document No. / Document n°.

CE 674

EU-Konformitätserklärung

Seite: 2 von 3

8 Declaration of conformity

JUMO GmbH & Co. KG

Moritz-Juchheim-Straße 1
36039 Fulda, Germany

Tel.: +49 661 6003-0
Fax: +49 661 6003-500

E-Mail: mail@jumo.net
Internet: www.jumo.net



More than  sensors + automation

Aussteller

Issued by / Etabli par

JUMO GmbH & Co. KG

Ort, Datum

Place, date / Lieu, date

Fulda, 2018-01-03

Rechtsverbindliche Unterschrift

Legally binding signature / Signature juridiquement valable

Bereichsleiter Verkauf
ppa. Wolfgang Vogl

Dokument-Nr.

Document No. / Document n°.

CE 674

EU-Konformitätserklärung

Seite: 3 von 3

JUMO MAERA S26 (Type 402090)

JUMO GmbH & Co. KG

Moritz-Juchheim-Straße 1
36039 Fulda, Germany

Tel.: +49 661 6003-0
Fax: +49 661 6003-500

E-Mail: mail@jumo.net
Internet: www.jumo.net



More than **sensors + automation**

EU-Konformitätserklärung

EU declaration of conformity / Déclaration UE de conformité

Dokument-Nr. <i>Document No. / Document n°.</i>	CE 684	
Hersteller <i>Manufacturer / Etabli par</i>	JUMO GmbH & Co. KG	
Anschrift <i>Address / Adresse</i>	Moritz-Juchheim-Straße 1, 36039 Fulda, Germany	
Produkt <i>Product / Produit</i>		
Name <i>Name / Nom</i>	Typ <i>Type / Type</i>	Typenblatt-Nr. <i>Data sheet no. / N° Document d'identification</i>
JUMO MAERA S26	402090	402090

Wir erklären in alleiniger Verantwortung, dass das bezeichnete Produkt die Anforderungen der Europäischen Richtlinien erfüllt.

We hereby declare in sole responsibility that the designated product fulfills the requirements of the European Directives.

Nous déclarons sous notre seule responsabilité que le produit remplit les Directives Européennes.

Richtlinie 1

Directive / Directive

Name EMC
Name / Nom

Fundstelle 2014/30/EU
Reference / Référence

Bemerkung
Comment / Remarque

Datum der Erstanbringung des CE-Zeichens auf dem Produkt 2002
*Date of first application of the CE mark to the product / Date
de 1ère application du sigle sur le produit*

Dokument-Nr.
Document No. / Document n°.

CE 684

EU-Konformitätserklärung

Seite: 1 von 3

8 Declaration of conformity

JUMO GmbH & Co. KG

Moritz-Juchheim-Straße 1
36039 Fulda, Germany

Tel.: +49 661 6003-0
Fax: +49 661 6003-500

E-Mail: mail@jumo.net
Internet: www.jumo.net



More than sensors + automation

Angewendete Normen/Spezifikationen

Standards/Specifications applied / Normes/Spécifications appliquées

Fundstelle <i>Reference / Référence</i>	Ausgabe <i>Edition / Édition</i>	Bemerkung <i>Comment / Remarque</i>
EN 61326-1	2013	
EN 61326-2-3	2013	

Gültig für Typ

Valid for Type / Valable pour le type

402090/...

Richtlinie 2

Directive / Directive

Name RoHS
Name / Nom

Fundstelle 2011/65/EU
Reference / Référence

Bemerkung
Comment / Remarque

Datum der Erstanbringung des CE-Zeichens auf dem Produkt 2017

Date of first application of the CE mark to the product / Date de 1ère application du sigle sur le produit

Angewendete Normen/Spezifikationen

Standards/Specifications applied / Normes/Spécifications appliquées

Fundstelle <i>Reference / Référence</i>	Ausgabe <i>Edition / Édition</i>	Bemerkung <i>Comment / Remarque</i>
VDK Umweltrelevante Aspekte bei der Produktentwicklung und -gestaltung	V1	

Gültig für Typ

Valid for Type / Valable pour le type

402090/...

Dokument-Nr.
Document No. / Document n°.

CE 684

EU-Konformitätserklärung

Seite: 2 von 3

8 Declaration of conformity

JUMO GmbH & Co. KG

Moritz-Juchheim-Straße 1
36039 Fulda, Germany

Tel.: +49 661 6003-0
Fax: +49 661 6003-500

E-Mail: mail@jumo.net
Internet: www.jumo.net



More than  sensors + automation

Aussteller

Issued by / Etabli par

JUMO GmbH & Co. KG

Ort, Datum

Place, date / Lieu, date

Fulda, 2018-01-03

Rechtsverbindliche Unterschrift

Legally binding signature / Signature juridiquement valable

Bereichsleiter Verkauf

ppa. Wolfgang Vogl

Dokument-Nr.

Document No. / Document n°.

CE 684

EU-Konformitätserklärung

Seite: 3 von 3

8 Declaration of conformity

JUMO MAERA F27 (Type 404391)

JUMO GmbH & Co. KG

Moritz-Juchheim-Straße 1
36039 Fulda, Germany

Tel.: +49 661 6003-0
Fax: +49 661 6003-500

E-Mail: mail@jumo.net
Internet: www.jumo.net



More than **sensors + automation**

EU-Konformitätserklärung

EU declaration of conformity / Déclaration UE de conformité

Dokument-Nr. <i>Document No. / Document n°.</i>	CE 692	
Hersteller <i>Manufacturer / Etabli par</i>	JUMO GmbH & Co. KG	
Anschrift <i>Address / Adresse</i>	Moritz-Juchheim-Straße 1, 36039 Fulda, Germany	
Produkt <i>Product / Produit</i>		
Name <i>Name / Nom</i>	Typ <i>Type / Type</i>	Typenblatt-Nr. <i>Data sheet no. / N° Document d'identification</i>
JUMO MAERA F27	404391	404391

Wir erklären in alleiniger Verantwortung, dass das bezeichnete Produkt die Anforderungen der Europäischen Richtlinien erfüllt.

We hereby declare in sole responsibility that the designated product fulfills the requirements of the European Directives.

Nous déclarons sous notre seule responsabilité que le produit remplit les Directives Européennes.

Richtlinie 1

Directive / Directive

Name EMC
Name / Nom

Fundstelle 2014/30/EU
Reference / Référence

Bemerkung
Comment / Remarque

Datum der Erstanbringung des CE-Zeichens auf dem Produkt 2000
*Date of first application of the CE mark to the product / Date
de 1ère application du sigle sur le produit*

Dokument-Nr.
Document No. / Document n°.

CE 692

EU-Konformitätserklärung

Seite: 1 von 3

8 Declaration of conformity

JUMO GmbH & Co. KG

Moritz-Juchheim-Straße 1
36039 Fulda, Germany

Tel.: +49 661 6003-0
Fax: +49 661 6003-500

E-Mail: mail@jumo.net
Internet: www.jumo.net



More than sensors + automation

Angewendete Normen/Spezifikationen

Standards/Specifications applied / Normes/Spécifications appliquées

Fundstelle

Reference / Référence

EN 61326-1

EN 61326-2-3

Ausgabe

Edition / Édition

2013

2013

Bemerkung

Comment / Remarque

Gültig für Typ

Valid for Type / Valable pour le type

404391/...

Richtlinie 2

Directive / Directive

Name

Name / Nom

RoHS

Fundstelle

Reference / Référence

2011/65/EU

Bemerkung

Comment / Remarque

Datum der Erstanbringung des CE-Zeichens 2017

auf dem Produkt

Date of first application of the CE mark to the product / Date

de 1ère application du sigle sur le produit

Angewendete Normen/Spezifikationen

Standards/Specifications applied / Normes/Spécifications appliquées

Fundstelle

Reference / Référence

VDK Umweltrelevante Aspekte V1

bei der Produktentwicklung und

-gestaltung

Ausgabe

Edition / Édition

Bemerkung

Comment / Remarque

Gültig für Typ

Valid for Type / Valable pour le type

404391/...

Dokument-Nr.

Document No. / Document n°.

CE 692

EU-Konformitätserklärung

Seite: 2 von 3

8 Declaration of conformity

JUMO GmbH & Co. KG

Moritz-Juchheim-Straße 1
36039 Fulda, Germany

Tel.: +49 661 6003-0
Fax: +49 661 6003-500

E-Mail: mail@jumo.net
Internet: www.jumo.net



More than  sensors + automation

Aussteller

Issued by / Etabli par

JUMO GmbH & Co. KG

Ort, Datum

Place, date / Lieu, date

Fulda, 2018-01-03

Rechtsverbindliche Unterschrift

Legally binding signature / Signature juridiquement valable

Bereichsleiter Verkauf
ppa. Wolfgang Vogl

Dokument-Nr.

Document No. / Document n°.

CE 692

EU-Konformitätserklärung

Seite: 3 von 3

JUMO MAERA S28 (Type 404392)

JUMO GmbH & Co. KG

Moritz-Juchheim-Straße 1
36039 Fulda, Germany

Tel.: +49 661 6003-0
Fax: +49 661 6003-500

E-Mail: mail@jumo.net
Internet: www.jumo.net



More than **sensors + automation**

EU-Konformitätserklärung

EU declaration of conformity / Déclaration UE de conformité

Dokument-Nr.

CE 693

Document No. / Document n°.

Hersteller

JUMO GmbH & Co. KG

Manufacturer / Etabli par

Anschrift

Moritz-Juchheim-Straße 1, 36039 Fulda, Germany

Address / Adresse

Produkt

Product / Produit

Name

Name / Nom

Typ

Type / Type

Typenblatt-Nr.

Data sheet no. / N°

Document

d'identification

JUMO MAERA S28

404392

404392

Wir erklären in alleiniger Verantwortung, dass das bezeichnete Produkt die Anforderungen der Europäischen Richtlinien erfüllt.

We hereby declare in sole responsibility that the designated product fulfills the requirements of the European Directives.

Nous déclarons sous notre seule responsabilité que le produit remplit les Directives Européennes.

Richtlinie 1

Directive / Directive

Name

Name / Nom

EMC

Fundstelle

Reference / Référence

2014/30/EU

Bemerkung

Comment / Remarque

Datum der Erstanbringung des CE-Zeichens 2013

auf dem Produkt

Date of first application of the CE mark to the product / Date

de 1ère application du sigle sur le produit

Dokument-Nr.

CE 693

Document No. / Document n°.

EU-Konformitätserklärung

Seite: 1 von 3

8 Declaration of conformity

JUMO GmbH & Co. KG

Moritz-Juchheim-Straße 1
36039 Fulda, Germany

Tel.: +49 661 6003-0
Fax: +49 661 6003-500

E-Mail: mail@jumo.net
Internet: www.jumo.net



More than sensors + automation

Angewendete Normen/Spezifikationen

Standards/Specifications applied / Normes/Spécifications appliquées

Fundstelle

Reference / Référence

EN 61326-1

EN 61326-2-3

Ausgabe

Edition / Édition

2013

2013

Bemerkung

Comment / Remarque

Gültig für Typ

Valid for Type / Valable pour le type

404392/...

Richtlinie 2

Directive / Directive

Name

Name / Nom

RoHS

Fundstelle

Reference / Référence

2011/65/EU

Bemerkung

Comment / Remarque

Datum der Erstanbringung des CE-Zeichens 2017

auf dem Produkt

Date of first application of the CE mark to the product / Date

de 1ère application du sigle sur le produit

Angewendete Normen/Spezifikationen

Standards/Specifications applied / Normes/Spécifications appliquées

Fundstelle

Reference / Référence

VDK Umweltrelevante Aspekte V1

bei der Produktentwicklung und

-gestaltung

Ausgabe

Edition / Édition

Bemerkung

Comment / Remarque

Gültig für Typ

Valid for Type / Valable pour le type

404392/...

Dokument-Nr.

Document No. / Document n°.

CE 693

EU-Konformitätserklärung

Seite: 2 von 3

8 Declaration of conformity

JUMO GmbH & Co. KG

Moritz-Juchheim-Straße 1
36039 Fulda, Germany

Tel.: +49 661 6003-0
Fax: +49 661 6003-500

E-Mail: mail@jumo.net
Internet: www.jumo.net



More than  sensors + automation

Aussteller

Issued by / Etabli par

JUMO GmbH & Co. KG

Ort, Datum

Place, date / Lieu, date

Fulda, 2018-01-03

Rechtsverbindliche Unterschrift

Legally binding signature / Signature juridiquement valable

Bereichsleiter Verkauf
ppa. Wolfgang Vogl

A handwritten signature in blue ink, appearing to read "W. Vogl", positioned below the printed name.

Dokument-Nr.

Document No. / Document n°.

CE 693

EU-Konformitätserklärung

Seite: 3 von 3

9 Maintenance, cleaning and returns

9.1 Maintenance



NOTE!

JUMO level probes are maintenance-free.

9.2 Cleaning



NOTE!

The cleaning agent used must not attack the material on the probe body or the seals. Mechanical damage to the membrane and the cable must be avoided.



NOTE!

Terminal case with pressure compensation element (accessories, part no. 00061206): Keep the filter free from pollutants!

9.3 Returns



NOTE!

All documents important for the return as well as the return address of the manufacturer are available at <http://productreturn.jumo.info>.



CAUTION!

Only dismantle the level probe in a currentless condition.

As further damage may be caused by dismantling the device, it should be ensured that neither the level probe with membrane nor the cable suffer mechanical damage.

JUMO MAERA S25 (Type 401015)

							
产品组别 Product group: 401015		产品中有害物质的名称及含量 China EEP Hazardous Substances Information					
部件名称 Component Name							
		铅 (Pb)	汞 (Hg)	镉 (Cd)	六价铬 (Cr(VI))	多溴联苯 (PBB)	多溴二苯醚 (PBDE)
外壳 Housing (Gehäuse)	○	○	○	○	○	○	
过程连接 Process connection (Prozessanschluss)	○	○	○	○	○	○	
螺母 Nuts (Mutter)	○	○	○	○	○	○	
螺栓 Screw (Schraube)	○	○	○	○	○	○	
本表格依据SJ/T 11364的规定编制。 This table is prepared in accordance with the provisions SJ/T 11364. ○ : 表示该有害物质在该部件所有均质材料中的含量均在GB/T 26572规定的限量要求以下。 Indicate the hazardous substances in all homogeneous materials' for the part is below the limit of the GB/T 26572. × : 表示该有害物质至少在该部件的某一均质材料中的含量超出GB/T 26572规定的限量要求。 Indicate the hazardous substances in at least one homogeneous materials' of the part is exceeded the limit of the GB/T 26572.							

10 China RoHS

JUMO MAERA S26 (Type 402090)

						
产品组别 Product group: 402090	产品中有害物质的名称及含量 China EEP Hazardous Substances Information					
部件名称 Component Name						
	铅 (Pb)	汞 (Hg)	镉 (Cd)	六价铬 (Cr(VI))	多溴联苯 (PBB)	多溴二苯醚 (PBDE)
外壳 Housing (Gehäuse)	○	○	○	○	○	○
过程连接 Process connection (Prozessanschluss)	○	○	○	○	○	○
螺母 Nuts (Mutter)	○	○	○	○	○	○
螺栓 Screw (Schraube)	○	○	○	○	○	○
本表格依据SJ/T 11364的规定编制。 This table is prepared in accordance with the provisions SJ/T 11364. ○ : 表示该有害物质在该部件所有均质材料中的含量均在GB/T 26572规定的限量要求以下。 Indicate the hazardous substances in all homogeneous materials' for the part is below the limit of the GB/T 26572. × : 表示该有害物质至少在该部件的某一均质材料中的含量超出GB/T 26572规定的限量要求。 Indicate the hazardous substances in at least one homogeneous materials' of the part is exceeded the limit of the GB/T 26572.						

JUMO MAERA F27 (Type 404391)

						
产品组别 Product group: 404391	产品中有害物质的名称及含量 China EEP Hazardous Substances Information					
部件名称 Component Name						
	铅 (Pb)	汞 (Hg)	镉 (Cd)	六价铬 (Cr(VI))	多溴联苯 (PBB)	多溴二苯醚 (PBDE)
外壳 Housing (Gehäuse)	○	○	○	○	○	○
过程连接 Process connection (Prozessanschluss)	○	○	○	○	○	○
螺母 Nuts (Mutter)	○	○	○	○	○	○
螺栓 Screw (Schraube)	○	○	○	○	○	○
<p>本表格依据SJ/T 11364的规定编制。 This table is prepared in accordance with the provisions SJ/T 11364.</p> <p>○：表示该有害物质在该部件所有均质材料中的含量均在GB/T 26572规定的限量要求以下。 Indicate the hazardous substances in all homogeneous materials' for the part is below the limit of the GB/T 26572.</p> <p>×：表示该有害物质至少在该部件的某一均质材料中的含量超出GB/T 26572规定的限量要求。 Indicate the hazardous substances in at least one homogeneous materials' of the part is exceeded the limit of the GB/T 26572.</p>						

10 China RoHS

JUMO MAERA S28 (Type 404392)

							
产品组别 Product group: 404392		产品中有害物质的名称及含量 China EEP Hazardous Substances Information					
部件名称 Component Name							
		铅 (Pb)	汞 (Hg)	镉 (Cd)	六价铬 (Cr(VI))	多溴联苯 (PBB)	多溴二苯醚 (PBDE)
外壳 Housing (Gehäuse)	○	○	○	○	○	○	
过程连接 Process connection (Prozessanschluss)	○	○	○	○	○	○	
螺母 Nuts (Mutter)	○	○	○	○	○	○	
螺栓 Screw (Schraube)	○	○	○	○	○	○	
本表格依据SJ/T 11364的规定编制。 This table is prepared in accordance with the provisions SJ/T 11364. ○ : 表示该有害物质在该部件所有均质材料中的含量均在GB/T 26572规定的限量要求以下。 Indicate the hazardous substances in all homogeneous materials' for the part is below the limit of the GB/T 26572. × : 表示该有害物质至少在该部件的某一均质材料中的含量超出GB/T 26572规定的限量要求。 Indicate the hazardous substances in at least one homogeneous materials' of the part is exceeded the limit of the GB/T 26572.							



JUMO GmbH & Co. KG

Street address:
Moritz-Juchheim-Straße 1
36039 Fulda, Germany

Delivery address:
Mackenrodtstraße 14
36039 Fulda, Germany

Postal address:
36035 Fulda, Germany

Phone: +49 661 6003-0
Fax: +49 661 6003-607
Email: mail@jumo.net
Internet: www.jumo.net

JUMO Instrument Co. Ltd.

JUMO House
Temple Bank, Riverway
Harlow, Essex, CM20 2DY, UK

Phone: +44 1279 63 55 33
Fax: +44 1279 62 50 29
Email: sales@jumo.co.uk
Internet: www.jumo.co.uk

JUMO Process Control, Inc.

6733 Myers Road
East Syracuse, NY 13057, USA

Phone: +1 315 437 5866
Fax: +1 315 437 5860
Email: info.us@jumo.net
Internet: www.jumousa.com

