

Fuzzy + PID Process / Temperature Controller

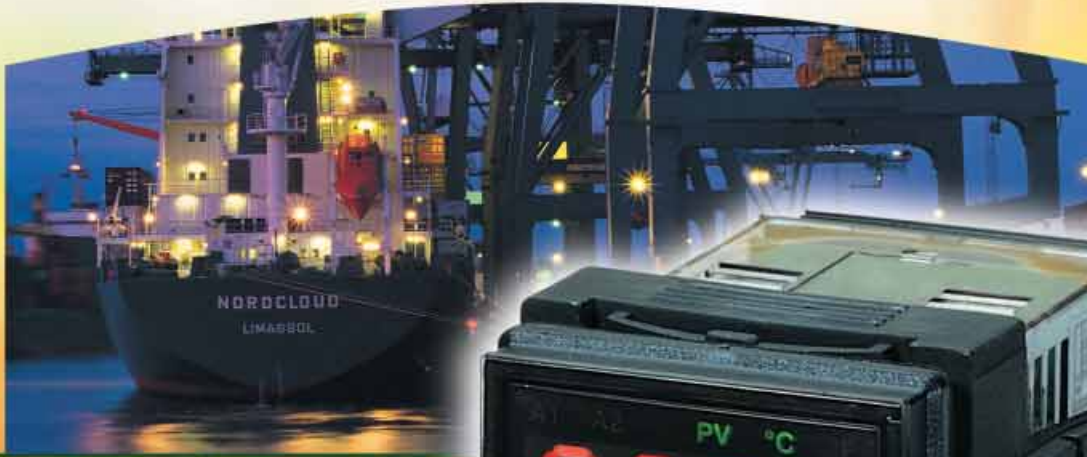

FEATURES

- High accuracy 18-bit input A-D
- High accuracy 15-bit output D-A
- Fast input sample rate (5 times / second)
- Basic & full function
- User menu configurable
- Pump control
- Fuzzy+PID microprocessor-based control
- Automatic programming
- Differential control
- Auto-tune function
- Self-tune function
- Sleep mode function
- "Soft-start" ramp and dwell timer
- Programmable inputs (thermocouple, RTD, mA, VDC)
- Analog input for remote set point and CT
- Event input for changing function & set point
- Programmable digital filter
- Hardware lockout + remote lockout protection
- Loop break alarm
- Heater break alarm
- Sensor break alarm + Bumpless transfer
- RS-485, RS-232 communication
- Analog retransmission
- Signal conditioner DC power supply
- A wide variety of output modules available
- Safety UL / CSA / IEC1010-1
- EMC / CE EN 61326



BTC-4300



BTC-8300



BTC-9300



BTC-2500



Overview

The Fuzzy Logic plus PID microprocessor-based controller series, incorporates a bright, easy to read 4-digit LED display, indicating process value and set point value. The Fuzzy Logic technology enables a process to reach a predetermined set point in the shortest time, with the minimum of overshoot during power-up or external load disturbance.

BTC-9300 is a 1/16 DIN size panel mount controller,
BTC-2500 is a 1/32 DIN size panel mount controller,
BTC-8300 is a 1/8 DIN size panel mount controller
and BTC-4300 is a 1/4 DIN size panel mount controller.

These units are powered by 11-26 VDC or 90-264 VAC supply, incorporating a 2 amp. control relay output as standard. Alternative output options include triac, 5V logic output, linear current and linear voltage. The units are fully programmable for PT100 and thermocouple types J, K, T, E, B, R, S, N, L with no need to modify the unit. The input signal is digitized by using a 18-bit A to D converter. Its fast sampling rate allows the unit to control fast processes.

Digital communications RS-485 or RS-232 are available as an additional option. These options allow the units to be integrated with supervisory control system and software.

A programming port is available for loading the configuration data with no need to use the keypads on front panel.

By using proprietary Fuzzy modified PID technology, the control loop will minimize the overshoot and undershoot in the shortest time. The following diagram is a comparison of results with and without Fuzzy technology.

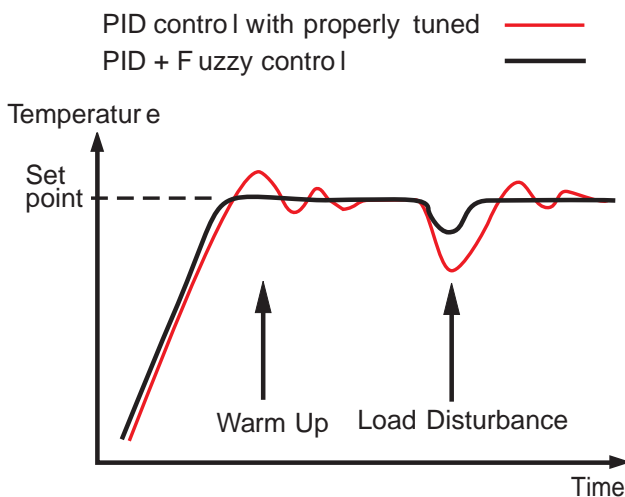

High Accuracy

The series are manufactured with custom designed ASIC (Application Specific Integrated Circuit) technology which contains a 18-bit A to D converter for high resolution measurement (true 0.1°F resolution for thermocouple and PT100) and a 15-bit D to A converter for linear current or voltage control output. The ASIC technology provides improved operating performance, low cost, enhanced reliability and higher density.

Fast Sampling Rate

The sampling rate of the input A to D converter reaches 5 times/second. The fast sampling rate allow sthis series to control fast processes.

Fuzzy Control

The function of Fuzzy control is to adjust PID parameters from time to time in order to making manipulation output value more flexible and adaptive to various processes. The results is to enable a process to reach a predetermined set point in the shortest time, with the minimum of overshoot and undershoot during power-up or external load disturbance.

Digital Communication

The units are equipped with RS-485 or RS-232 interface card to provide digital communication. By using the twisted pair wires there are at most 247 units can be connected together via RS-485 interface to a host computer.

Programming Port

A programming port is used to connect the unit to a PC for quick configuration, also can be connected to an ATE system for automatic testing & calibration.

Auto-tune

The auto-tune function allows the user to simplify initial setup for a new system. A clever algorithm is provided to obtain an optimal set of control parameters for the process, and it can be applied either as the process is warming up (cold start) or as the process has been in steady state (warm start).

Lockout Protection

The parameters can be locked to prevent from being changed by using either Hardware lockout or Remote lockout or both.

Bumpless Transfer

Bumpless transfer allows the controller to continue to control by using its previous value as the sensor breaks. Hence, the process can be well controlled temporarily as if the sensor is normal.

Soft-start Ramp

The ramping function is performed during power up as well as any time the set point is changed. It can be ramping up or ramping down. The process value will reach the set point with a predetermined constant rate.

Digital Filter

A first order low pass filter with a programmable time constant is used to improve the stability of process value. This is particularly useful in certain application where the process value is too unstable to read.

SEL Function

The units have the flexibility for user to select those parameters which is most significant to him and put these parameters in the front of display sequence. There are at most 5 parameters can be selected to allow the user to build his own display sequence.

Pump Control

Only the superior noise rejection capability in addition to the fast sampling rate owned by this series of controllers can control the water pressure in a pump system which is driven by a variable speed motor.

Connection Diagrams

BTC-4300, BTC-8300

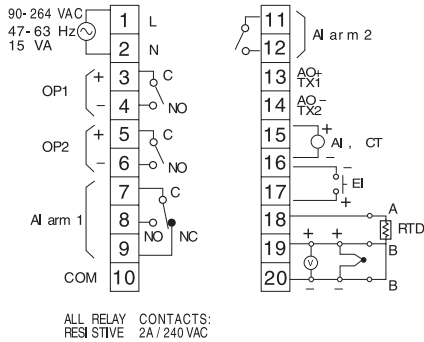

BTC-9300

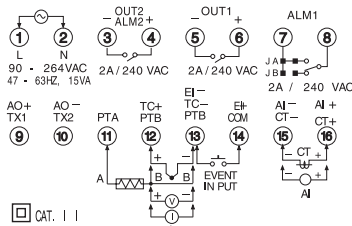

BTC-2500

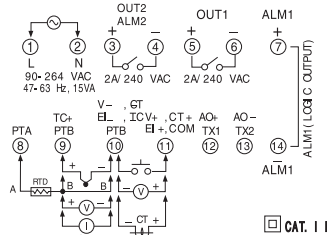

Specifications

Power

90 - 264 VAC, 47 63 Hz, 15VA, 7W maximum
11 - 26 VAC / VDC, 15VA, 7W maximum

Input 1

Characteristics :

Type	Range	Accuracy @25°C	Input Impedance
J	-120°C -1000°C (-184°F -1832°F)	±2°C	2.2MΩ
K	-200°C -1370°C (-328°F -2498°F)	±2°C	2.2MΩ
T	-250°C -400°C (-418°F -752°F)	±2°C	2.2MΩ
E	-100°C -900°C (-148°F -1652°F)	±2°C	2.2MΩ
B	0°C -1820°C (32°F -3308°F)	±2°C (200°C - 1820°C)	2.2MΩ
R	0°C -1767.8°C (32°F -3214°F)	±2°C	2.2MΩ
S	0°C -1767.8°C (32°F -3214°F)	±2°C	2.2MΩ
N	-250°C -1300°C (-418°F -2372°F)	±2°C	2.2MΩ
L	-200°C -900°C (-328°F -1652°F)	±2°C	2.2MΩ
PT100 (DIN)	-210°C -700°C (-346°F -1292°F)	±0.4°C	1.3KΩ
PT100 (JIS)	-200°C -600°C (-328°F -1112°F)	±0.4°C	1.3KΩ
mV	-8mV -70mV	±0.05%	2.2MΩ
mA	-3mA -27mA	±0.05%	70.5Ω
V	-1.3V -11.5V	±0.05%	302KΩ

Resolution : 18 bits

Sampling Rate : 5 times / second

Maximum Rating : -2 VDC minimum, 12 VDC maximum
(1 minute for mA input)

Temperature Effect : ±1.5 uV/ °C for all inputs except mA
input ±3.0 uV/ °C for mA input

Sensor Lead Resistance Effect :

T/C: 0.2uV/ohm

3-wire RTD: 2.6 °C/ohm of resistance difference of two leads

2-wire RTD: 2.6 °C/ohm of resistance sum of two leads 200nA

Common Mode Rejection Ratio (CMRR) : 120dB

Normal Mode Rejection Ratio (NMRR) : 55dB

Sensor Break Detection :

Sensor open for TC, RTD and mV inputs,

below 1 mA for 4-20 mA input,

below 0.25V for 1 - 5 V input, unavailable for other inputs.

Sensor Break Responding Time :

Within 4 seconds for TC, RTD and mV inputs,

0.1 second for 4-20 mA and 1 - 5 V inputs.

Input 2

Resolution : 18 bits

Sampling Rate : 1.66 times / second

Maximum Rating : -2 VDC minimum, 12 VDC maximum

Temperature Effect : ±1.5uV/ °C for all inputs except mA

input ±3.0uV/ °C for mA input

Common Mode Rejection Ratio (CMRR) : 120dB

Normal Mode Rejection Ratio (NMRR) : 55dB

Sensor Break Detection : Below 1 mA for 4-20 mA input,

below 0.25V for 1 - 5V input,

unavailable for other inputs.

Sensor Break Responding Time : 0.5 second

Characteristics :

Type	Range	Accuracy @25°C of Reading ±0.2 A	Input Impedance
CT94-1	0-50.0 A	±2%	302 KΩ
mA	-3mA-27mA	±0.05%	70.5 + $\frac{0.8V}{\text{input current}}$
V	-1.3V-11.5V	±0.05%	302 KΩ

Input 3 (Event Input)

Logic Low : -10V minimum, 0.8V maximum.

Logic High : 2V minimum, 10V maximum

External pull-down Resistance : 400 KΩ maximum

External pull-up Resistance : 1.5 MΩ minimum

Functions :

Select second set point and/or PID , reset alarm 1 and/or alarm 2 , disable output 1 and/or output 2 , remote lockout.

Output 1 / Output 2

Relay Rating : 2A/240 VAC, life cycles 200,000 for resistive load

Pulsed Voltage : Source Voltage 5V, current limiting resistance 66Ω .

Linear Output Characteristics

Type	Zero Tolerance	Span Tolerance	Load Capacity
4-20 mA	3.8-4 mA	20-21 mA	500Ω max.
0-20 mA	0 mA	20-21 mA	500Ω max.
0-5 V	0 V	5-5.25 V	10KΩ min.
1-5 V	0.95-1 V	5-5.25 V	10KΩ min.
0-10 V	0 V	10-10.5 V	10KΩ min.

Linear Output

Resolution : 15 bits

Output Regulation : 0.01 % for full load change

Output Settling Time : 0.1 sec. (stable to 99.9 %)

Isolation Breakdown Voltage : 1000 VAC

Temperature Effect : ±0.0025 % of SPAN / °C

Triac (SSR) Output

Rating : 1A / 240 VAC

Inrush Current : 20A for 1 cycle

Min. Load Current : 50 mA rms

Max. Off-state Leakage : 3 mA rms

Max. On-state Voltage : 1.5 V rms

Insulation Resistance : 1000 Mohms min. at 500 VDC

Dielectric Strength : 2500 VAC for 1 minute

DC Voltage Supply Characteristics (Installed at Output 2)

Type	Tolerance	Max. Output Current	Ripple Voltage	Isolation Barrier
20 V	±0.5 V	25 mA	0.2 Vp-p	500 VAC
12 V	±0.3 V	40 mA	0.1 Vp-p	500 VAC
5 V	±0.15 V	80 mA	0.05 Vp-p	500 VAC

Alarm 1/ Alarm 2 (Output 2)

Alarm 1 Relay :

Form A or Form B for BTC-9300, Form C for BTC4300, BTC-8300, 5V Logic output for BTC-2500 Max. Rating 2A/240VAC, life cycles 200,000 for resistive load. life cycles 200,000 for resistive load.

Alarm 2 Relay :

Form A, Max. rating 2A/240VAC, life cycles 200,000 for resistive load.

Alarm Functions :

Dwell timer, Deviation High / Low Alarm,
Deviation Band High / Low Alarm, PV1 High / Low Alarm,
PV2 High / Low Alarm, PV1 or PV2 High /Low Alarm,
PV1-PV2 High /Low Alarm, Loop Break Alarm,
Sensor Break Alarm.

Alarm Mode : Normal, Latching, Hold, Latching / Hold.

Dwell Timer : 0 - 6553.5 minutes

Data Communication

Interface : RS-232 (1 unit), RS-485 (up to 247 units)

Protocol : Modbus Protocol RTU mode

Address : 1 - 247

Baud Rate : 0.3 ~ 38.4 Kbits/sec

Data Bits : 7 or 8 bits

Parity Bit : None, Even or Odd

Stop Bit : 1 or 2 bits

Communication Buffer : 50 bytes

Analog Retransmission

Functions : PV1, PV2, PV1-PV2, PV2-PV1, Set Point, MV1, MV2, PV-SV deviation value

Output Signal : 4-20 mA, 0-20 mA, 0-1V, 0-5V, 1-5V, 0-10V

Resolution : 15 bits

Accuracy : ±0.05 % of span ±0.0025 %/ °C

Load Resistance : 0 - 500 ohms (for current output),
10 K ohms minimum (for voltage output)

Output Regulation : 0.01 % for full load change

Output Settling Time : 0.1 sec. (stable to 99.9 %)

Isolation Breakdown Voltage : 1000 VAC min.

Integral Linearity Error : ±0.005 % of span

Temperature Effect : ±0.0025 % of span/ LC

Saturation Low : 0 mA (or 0V)

Saturation High : 22.2 mA (or 5.55V, 11.1V min.)

Linear Output Range : 0 - 22.2mA(0-20mA or 4-20mA),
0 - 5.55V (0 - 5V, 1 - 5V),
0 - 11.1 V (0 - 10V)

User Interface

Dual 4-digit LED Displays :

BTC-4300	Upper 0.55" (14mm)
	Lower 0.4" (10 mm)
BTC-8300, BTC-9300	Upper 0.4" (10 mm)
	Lower 0.31" (8 mm)
BTC-2500	0.4"(10mm)

Keypad : 4 keys

Programming Port : For automatic setup, calibration and testing

Communication Port : Connection to PC for supervisory control

Control Mode

Output 1 : Reverse (heating) or direct (cooling)action

Output 2 : PID cooling control, cooling P band 1 ~ 255% of PB

ON-OFF : 0.1 - 55.6 (°C) hysteresis control (P band = 0)

P or PD : 0 - 100.0 % offset adjustment

PID : Fuzzy logic modified , Proportional band 0 ~ 500.0 °C ,

Integral time 0 - 1000 seconds , Derivative time 0 - 360.0 seconds

Cycle Time : 0.1 - 100.0 seconds

Manual Control : Heat (MV1) and Cool (MV2)

Auto-tuning : Cold start and warm start

Failure Mode : Auto-transfer to manual mode while sensor break
or A-D converter damage

Ramping Control : 0 ~ 500.0 °C/minute or

0 ~ 500.0 °C/hour ramp rate

Sleep Mode : Enable or Disable

Ramping Control : 0 ~ 500.0 °C/minute or 0 ~ 500.0 °C/hour
ramp rate

Power Limit : 0 - 100 % output 1 and output 2

Pump / Pressure Control : Sophisticated functions provided

Remote Set Point : Programmable range for voltage or
current input

Differential Control : Control PV1 - PV2 at set point

Digital Filter

Function : First order

Time Constant : 0, 0.2, 0.5, 1, 2, 5, 10, 20, 30, 60
seconds programmable

Environmental & Physical

Operating Temperature : -10°C to 50°C

Storage Temperature : -40°C to 60°C

Humidity : 0 to 90 % RH (non-condensing)

Insulation Resistance : 20 Mohms min. (at 500 VDC)

Dielectric Strength : 2000 VAC, 50/60 Hz for 1 minute

Vibration Resistance : 10 - 55 Hz, 10 m/s² for 2 hours

Shock Resistance : 200 m/s² (20 g)

Moldings : Flame retardant polycarbonate

Dimensions :

BTC-4300 ---96mm(W) X 96mm(H) X 66 mm(D),
53 mm depth behind panel

BTC-8300 ---48mm(W) X 96mm(H) X 80mm(D),
65 mm depth behind panel

BTC-9300 ---50.7mm(W) X 50.7mm(H) X 88.5mm(D),
75mm depth behind panel

BTC-2500 ---50mm(W) X 26.5mm(H) X 110.5 mm(D),
98.0 mm depth behind panel

Mounting:

BTC-4300 ---panel mount, cutout 92 X 92 (mm)

BTC-8300 ---panel mount, cutout 45 X 92 (mm)

BTC-9300 ---panel mount, cutout 45 X 45 (mm)

BTC-2500 ---panel mount, cutout 45 X 22.2 (mm)

Weight :

BTC-4300 --- 255 grams

BTC-8300 --- 220 grams

BTC-9300 --- 150 grams

BTC-2500 --- 120 grams

Approval Standards

Safety : UL 3121-1 , CSA C22.2 No. 24-93 ,
EN61010-1 (IEC1010-1)

Protective Class :

BTC-8300, BTC-4300:

IP 20 housing and terminals with protective covers.

BTC-2500, BTC-9300:

NEMA 4X(IP65) front panel , IP 20 housing and terminals

EMC : EN61325

Ordering Code

BTC-2500-

Power Input

- 4: 90 - 264 VAC, 50 / 60 HZ
- 5: 11 - 26 VAC or VDC
- 9: Special Order

Signal Input

- 1: Standard Input
 - Input 1-Universal Input
 - Thermocouple: J, K, T, E, B, R, S, N, L
 - RTD: PT100 DIN, PT100 JIS
 - Current: 4 - 20mA, 0 - 20mA
 - Voltage: 0 - 1V, 0 - 5V, 1 - 5V, 0-10V
 - Input 2-CT: 0 - 50 Amp. AC Current Transformer
 - Voltage Input: 0 - 1V, 0 - 5V, 1 - 5V, 0 - 10V
 - Event Input (EI)
- 9: Special Order

Output 1

- 0: None
- 1: Relay rated 2A / 240VAC
- 2: Pulsed voltage to drive SSR, 5V / 30mA
- 3: Isolated 4 - 20mA / 0 - 20mA
- 4: Isolated 1 - 5V / 0 - 5V
- 5: Isolated 0 - 10V
- 6: Triac output 1A / 240VAC, SSR
- 9: Special order

Output 2 / Alarm 2

- 0: None
- 1: Form A relay 2A / 240VAC
- 2: Pulsed voltage to drive SSR, 5V / 30mA
- 3: Isolated 4 - 20mA / 0 - 20mA
- 4: Isolated 1 - 5V / 0 - 5V
- 5: Isolated 0 - 10V
- 6: Triac output, 1A / 240VAC, SSR
- 7: Isolated 20V / 25 mA DC Output Power Supply
- 8: Isolated 12V / 40 mA DC Output Power Supply
- 9: Isolated 5V / 80 mA DC Output Power Supply
- A: Special order

Alarm 1

- 1: 5V Logic Output
- 9: Special order

Communications

- 0: None
- 1: RS-485 interface
- 2: RS-232 interface
- 3: Retransmit 4 - 20 mA / 0 - 20 mA
- 4: Retransmit 1 - 5V / 0 - 5V
- 5: Retransmit 0 - 10V
- 9: Special order

BTC-9300-

Power Input

- 4: 90 - 264 VAC, 50 / 60 HZ
- 5: 11 - 26 VAC or VDC
- 9: Special Order

Signal Input

- 1: Standard Input
 - Input 1-Universal Input
 - Thermocouple: J, K, T, E, B, R, S, N, L
 - RTD: PT100 DIN, PT100 JIS
 - Current: 4 - 20 mA, 0 - 20 mA
 - Voltage: 0 - 1V, 0 - 5V, 1 - 5V, 0 - 10V
 - Input 2-CT: 0 - 50 Amp. AC Current Transformer
 - Voltage Input: 0 - 1V, 0 - 5V, 1 - 5V, 0 - 10V
 - Input 3-Event Input (EI)
- 9: Special Order

Output 1

- 0: None
- 1: Relay rated 2A / 240VAC
- 2: Pulsed voltage to drive SSR, 5V / 30mA
- 3: Isolated 4 - 20mA / 0 - 20mA
- 4: Isolated 1 - 5V / 0 - 5V
- 5: Isolated 0 - 10V
- 6: Triac output 1A / 240VAC, SSR
- 9: Special order

Output 2 / Alarm 2

- 0: None
- 1: Form A relay 2A / 240VAC
- 2: Pulsed voltage to drive SSR, 5V / 30mA
- 3: Isolated 4-20mA / 0-20mA
- 4: Isolated 1-5V / 0-5V
- 5: Isolated 0-10V
- 6: Triac output, 1A / 240VAC, SSR
- 7: Isolated 20V-25mA DC Output Power Supply
- 8: Isolated 12V-40mA DC Output Power Supply
- 9: Isolated 5V-80mA DC Output Power Supply
- A: Special order

Alarm 1

- 0: None
- 1: Form A relay 2A / 240VAC
- 2: Form A relay 2A / 240VAC
- 9: Special order

Communications

- 0: None
- 1: RS-485 interface
- 2: RS-232 interface
- 3: Retransmit 4-20 mA / 0-20mA
- 4: Retransmit 1-5V / 0-5V
- 5: Retransmit 0-10V
- 9: Special order

BTC-8300 -
BTC-4300 -

Power Input

- 4: 90-264 VAC, 50 / 60 HZ
- 5: 11-26 VAC or VDC
- 9: Special Order

Signal Input

- 1: Standard Input
 - Input 1-Universal Input
 - Thermocouple: J, K, T, E, B, R, S, N, L
 - RTD: PT100 DIN, PT100 JIS
 - Current: 4 - 20mA, 0 - 20mA
 - Voltage: 0 - 1V, 0 - 5V, 1 - 5V, 0 -1 0V
 - Input 2 - CT: 0 - 50 Amp. AC Current Transformer
 - Voltage Input: 0 - 1V, 0 - 5V, 1 - 5V, 0 - 10V
 - Input 3-Event Input (EI)
- 9: Special Order

Output 1

- 0: None
- 1: Relay rated 2A / 240VAC
- 2: Pulsed voltage to drive SSR, 5V / 30mA
- 3: Isolated 4 - 20mA / 0 - 20mA
- 4: Isolated 1 - 5V / 0 - 5V
- 5: Isolated 0 - 10V
- 6: Triac output 1A / 240VAC, SSR
- 9: Special order

Output 2

- 0: None
- 1: Form A relay 2A / 240VAC
- 2: Pulsed voltage to drive SSR, 5V / 30mA
- 3: Isolated 4 - 20mA / 0-20mA
- 4: Isolated 1 - 5V / 0-5V
- 5: Isolated 0 - 10V
- 6: Triac output, 1A / 240VAC, SSR
- 7: Isolated 20V / 25mA DC Output Power Supply
- 8: Isolated 12V / 40mA DC Output Power Supply
- 9: Isolated 5V / 80mA DC Output Power Supply
- A: Special order

Alarm 1

- 0: None
- 1: Form C relay 2A / 240VAC
- 9: Special order

Alarm 2

- 0: None
- 1: Form A relay 2A / 240VAC
- 9: Special order

Communications

- 0: None
- 1: RS - 485 interface
- 2: RS - 232 interface
- 3: Retransmit 4 - 20mA / 0 - 20mA
- 4: Retransmit 1-5V / 0 - 5V
- 5: Retransmit 0 - 10V
- 9: Special order

Accessories

- CT94-1 = 0-50 Amp. AC Current Transformer
- OM95-3 = Isolated 4-20mA / 0-20mA Analog Output Module
- OM95-4 = Isolated 1 - 5V / 0-5V Analog Output Module
- OM95-5 = Isolated 0 - 10V Analog Output Module
- OM95-6 = Isolated 1A / 240VAC Triac Output Module (SSR)
- DC94-1 = Isolated 20V / 25 mA DC Output Power Supply
- DC94-2 = Isolated 12V / 40 mA DC Output Power Supply
- DC94-3 = Isolated 5V / 80 mA DC Output Power Supply
- CM94-1 = Isolated RS - 485 Interface Module
- CM94-2 = Isolated RS - 232 Interface Module
- CM94-3 = Isolated 4 - 20 mA / 0-20 mA Retransmission Module
- CM94-4 = Isolated 1 - 5V / 0 - 5V Retransmission Module
- CM94-5 = Isolated 0 - 10V Retransmission Module
- CC94-1 = RS-232 Interface Cable (2M)

Related Products

- SNA10A = Smart Network Adaptor for Third Party Software, converts 255 channels of RS-485 or RS-422 to RS-232 Network
- SNA10B = Smart Network Adaptor for BC-Net Software, converts 255 channels of RS-485 or RS-422 to RS-232 Network