

# XU2 Transmitter.

USB Programmable Isolating  
Universal-Input to 4~20mA Output  
Loop Powered Transmitter.

## Features.

- Programmable via USB (requires the **XU-USB** programming key).
- No power supply or calibration required during programming.
- Input types:
  - RTD Pt100 and Pt1000.
  - Thermocouple B, E, J, K, N, R, S, T.
  - For RTD and Thermocouple; Output is Linear with Temperature.
  - mA, mV, and V.
  - Potentiometer.
  - 32 point curve fitter for mA, mV, V inputs.
- Input to Output Isolation 3750Vac.
- High Accuracy 0.1%.
- Reverse Polarity Protected.
- Heartbeat Status LED.
- Zero Adjust pot.
- Case Temperature range -20°C to +80°C.
- Compact DIN Rail Mount Enclosure.
- Easy to Install.
- Low Cost.



## Ordering Information.

**XU2** USB Programmable Universal-Input.

Standard = RTD Pt100, 0~100°C Input; Upscale;  
4~20mA Output (Loop Powered).

**XU-USB** USB Programming Key Download free software via the link from: [www.intech.co.nz/xu2](http://www.intech.co.nz/xu2)

Note: The table below shows the USB programmable input types etc for the XU2:

The XU2 can be pre-programmed before dispatch or is easily programmed using the **XU-USB** programming key and the free XU programming software.

ITEM	CODE		DESCRIPTION
SERIES	<b>XU2-</b>		Universal Input Transmitter
Type of Input	<b>Pt100-</b>		RTD Pt100 DIN (Options JIS & CN10)
	<b>Pt1000-</b>		RTD Pt1000 DIN (Options JIS & CN10)
	<b>Tc</b> <input type="checkbox"/> -		Thermocouple Type; <b>B, E, J, K, N, R, S, T</b>
	<b>mA-</b>		mA Input impedance = 10Ω
	<b>mV-</b>		mV Input resistance = 300KΩ
	<b>V-</b>		V Input resistance = 300KΩ
	<b>Pot 1-</b>		Potentiometer Low = 1K~2KΩ
	<b>Pot 2-</b>		Potentiometer High = 5K~1MΩ
Measuring Range		-	State Measuring Range
Output Action on Sensor Fail (for Temperature Input types only)		<b>US</b>	Upscale
		<b>DS</b>	Downscale

## Ordering Examples:

- 1/ XU2 - Pt100 - 0~100C - DS XU2; RTD Pt100 DIN 0~100°C Input; Downscale; 4~20mA Output.
- 2/ XU2 - Tc K - 0~1200C - US XU2; Thermocouple Type K 0~1200°C Input; Upscale; 4~20mA Output.

**Product Liability.** This information describes our products. It does not constitute guaranteed properties and is not intended to affirm the suitability of a product for a particular application. Due to ongoing research and development, designs, specifications, and documentation are subject to change without notification. Regrettably, omissions and exceptions cannot be completely ruled out. No liability will be accepted for errors, omissions or amendments to this specification. Technical data are always specified by their average values and are based on Standard Calibration Units at 25C, unless otherwise specified. Each product is subject to the 'Conditions of Sale'.

**Warning: These products are not designed for use in, and should not be used for patient connected applications. In any critical installation an independent fail-safe back-up system must always be implemented.**

## XU2 Common Specifications.

Output	2-wire 4~20mA (Loop Powered)
Power Supply	10.5~36Vdc
Supply Voltage Sensitivity	< ±0.005%/V FSO
Output Load Resistance	700Ω at 24Vdc (50Ω/V above 10.5Vdc)
Maximum Output Current	Limited to <28mA (Emission and Immunity)
Emissions Compliance	EMC EN 61326
Immunity Compliance	EMC EN 61326
Safety Compliance	EMC EN 61010-1
Accurate to	<±0.03% FSO Typical
Ambient Drift	<±0.003%/°C FSO Typical
Noise Immunity	125dB CMRR Average (2.0kVdc Limit)
R.F. Immunity	<1% effect FSO Typical
Isolation Test Voltages	Between Input and Output: 3750Vac for 1min
Response Time	400msec Typical (10~90% 300msec Typical)
Sensor Fail	Low 3.8mA, High 21mA
Startup Time	3 seconds, 3.7mA output
Output calibrate via Pot	±0.5mA Zero offset adjust
Operating Temperature	-20~85°C
Storage Temperature	-20~100°C
Operating Humidity	5~85%RH MAX (Non-Condensing)
Mounting	35mm Symmetrical DIN Rail
Dimensions	H=79, W=20, D=68mm

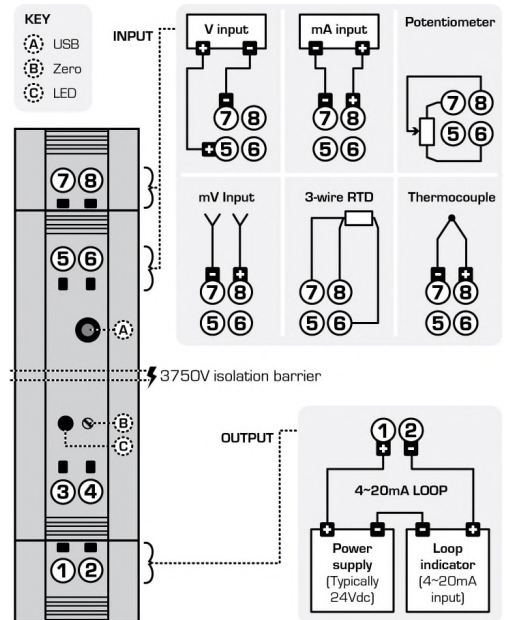

Heartbeat LED:	
LED Indication:	Status:
LED on for 2 seconds	Startup
½ sec on, ½ sec off	Good
3 Sec on, 1 Sec off	Sensor Break
Always on	Fault
Always off	Fault or no 4~20mA current

### Voltage Input Specifications.

USB Programmable Zero	0~±99% of the Span
USB Programmable Span	±100mVdc to ±10Vdc and Bipolar
Minimum Input Resistance	300kΩ
mV Maximum Over-range	3Vdc Continuous
V Maximum Over-range	60Vdc Continuous
Linearity and Repeatability	<±0.02% FSO Typical
<b>WARNING: Do NOT apply a V input greater than 3V to mV terminals!</b>	

### Current Input Specifications.

USB Programmable Zero	0~±99% of the Span
USB Programmable Span	1μAdc~24mAdc
	Standard range = 4~20mA
Minimum Recommended Span	0~1mA (gives 1000 steps on output)
Input Resistance	10Ω
Maximum Over-range	50mAdc Continuous
Linearity and Repeatability	<±0.02% FSO Typical

### Thermocouple (T/C) Input Specifications.

Thermocouple Types	B, E, J, K, N, R, S, T
USB Programmable Zero	0~±99% of the Span
USB Programmable Span	Within Thermocouple Type limits
Input Impedance	1MΩ Minimum
T/C Lead Resistance	100Ω Maximum
Cold Junction Comp.	-20~90°C
Accuracy	E, J, K, N, T <±1°C B, R, S <±2°C
Temperature Drift	E, J, K, N, T <±0.05°C B, R, S <±0.2°C
CJC Error	<±1°C
Sensor Break Output Drive	Func High Upscale Func Low Downscale

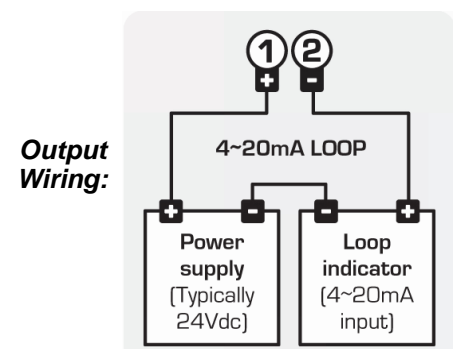
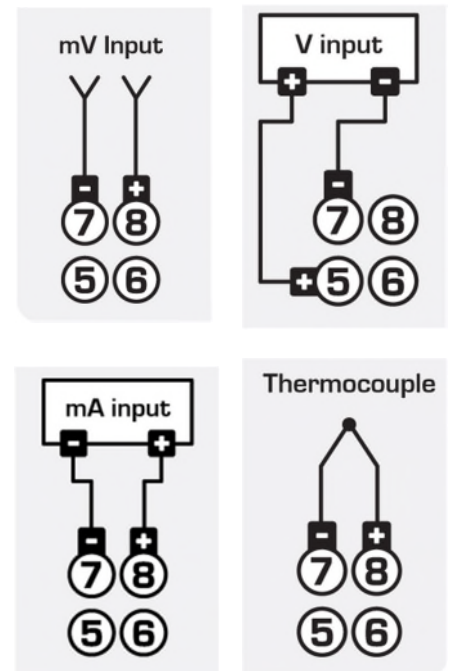

### RTD Input Specifications.

RTD Input	Pt100 or Pt1000 DIN 3-wire Type. (2-wire can be used with offset calibration)
Sensor Current	0.15mA Nominal
Lead Wire Resistance	Pt100: 10Ω/wire Maximum Pt1000: 5Ω/wire Maximum 0.02% FSO Offset Error per Ω of Lead Resistance
USB Programmable Zero	0~±99% of the Span
USB Programmable Span	-200~850°C
Sensor Break Output Drive	Funct High Upscale Funct Low Downscale
Linearity (Pt100)	0.02% FSO for Span Inputs ≤200°C. 0.1% FSO for Span Inputs ≤850°C
Linearity (Pt1000)	0.02% FSO for Span Inputs ≤200°C. 0.2% FSO for Span Inputs ≤520°C
Other Available RTD Types	JIS and CN10

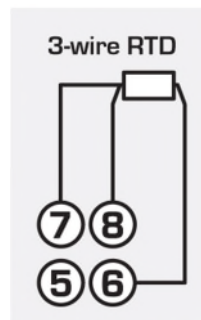

### Potentiometer Input Specifications.

Potentiometer Input	3-wire Potentiometer
Excitation Voltage	1.2Vdc
Potentiometer Resistance	Low Range 1K~2KΩ High Range 5K~1MΩ
USB Programmable Zero	0~90% of the Span
USB Programmable Span	0.1~100%
Linearity and Repeatability	<±0.02% FSO Typical

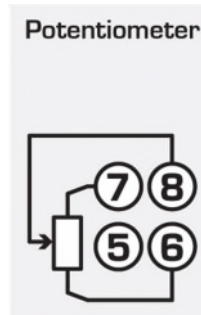

### XU2 Wiring, Installation and Maintenance.

**The XU2 is to be Installed and Serviced by Service Personnel Only. No Operator / User Serviceable Parts.**

All power and signals must be de-energised before connecting any wiring.

#### Mounting.

\* Also refer to Connection Diagrams and Notes.

- (1) Mount in a clean environment in an electrical cabinet on 35mm Symmetrical mounting rail.
- (2) Draft holes must have minimum free air space of 20mm. Foreign matter must not enter or block draft holes.
- (3) Do not subject to vibration or excess temperature or humidity variations.
- (4) Avoid mounting in cabinets with power control equipment.
- (5) To maintain compliance with the EMC Directives the XU2 is to be mounted in a fully enclosed steel fire cabinet. The cabinet must be properly earthed, with appropriate input / output entry points and cabling.
- (6) Allow 10mm minimum clearance between the XU2 terminals and ANY conductive material.

#### Analogue Signal Wiring.

- (1) All signal cables should be good quality overall screened INSTRUMENTATION CABLE with the screen earthed at one end only.
- (2) Signal cables should be laid a minimum distance of 300mm from any power cables.
- (3) For 2 wire current loops, 2 wire voltage signals or 2 wire current signals, Austral Standard Cables B5102ES is recommended. For 3 wire transmitters and RTDs Austral Standard Cables B5103ES is recommended.
- (5) It is recommended that you do not ground analogue signals and use power supplies with ungrounded outputs.
- (6) Lightning arrestors should be used when there is a danger from this source.
- (7) Refer to diagrams for connection information. Observe polarity and the correct terminal connections for wiring correctly.

#### Potentiometers.

- (1) Use only good quality, sealed, accurate Potentiometer Sensors. Check that the operating temperature, mechanical and electrical loading, specifications, rotational life etc meet the application.
- (2) Use Potentiometer Sensors with better than 5% resistance tolerance and less than 100ppm/C FSO temperature drift. Note that the minimum Potentiometer resistance for the XU2 is 1KΩ.

#### Thermocouples.

- (1) Avoid locating the Thermocouple where it will be in a direct flame.
- (2) Never insert a porcelain or refractory tube suddenly in a hot area. Pre-heat gradually while installing.
- (3) Locate it where the average temperature will be measured. It should be representative of the mass. If necessary use several Thermocouples to obtain the average temperature.
- (4) Immerse the Thermocouple far enough so that the measuring junction is entirely in the temperature to be measured: nine to ten times the diameter of the protection tube is recommended. Heat conducted away from the junction causes an error in reading.
- (5) If the Thermocouple is mounted horizontally and the temperature is above the softening point of the tube, a support should be provided to prevent the tube sagging. Otherwise install the tube vertically.
- (6) Keep the junction head and cold junction in the approximation of the ambient temperature. Especially in the Noble Metal Class.

### Thermocouple Extension Wire.

- (1) Use the correct Thermocouple extension or compensation cable. I.e. Thermocouple type, insulation type, colour coding.
- (2) It is recommended to install extension or compensation cable in a grounded conduit by themselves, or use overall screened cable with the screen earthed at one end only. Never run electrical wires in the same conduit.
- (3) All wires that must be spliced should be soldered, or a proper Thermocouple termination block used.
- (4) Lightning arrestors should be used if there is a danger from this source.

### RTDs.

- (1) Avoid locating the RTD where it will be in a direct flame.
- (2) Locate it where the average temperature will be measured. It should be representative of the mass.
- (3) Immerse the RTD far enough so that the measuring point is entirely in the temperature to be measured; nine to ten times the diameter of the protection tube is recommended. Heat that is conducted away from the measuring point causes an error in reading.

### XU2 Commissioning.

- (1) **WARNING: Ensure that all programming is carried out BEFORE any wiring takes place!**
- (2) Check that the XU2 has been set to the correct input ranges and all functions such as Upscale/Downscale Drive and CJC etc. Observe polarity and the correct terminal connections for wiring correctly. Only use certified calibration equipment. For Thermocouple calibration place the XU2 and calibration equipment directly next to each other, in still air, with no direct sunshine. Allow both CJC junctions to equalise in temperature before commencing calibration. Lower temperature ranges are affected more by the CJC Junction (allow more time to equalise).
- (3) Once the above conditions have been met, and the wiring checked, apply power to the XU2, and associated current loops, transducers, sensors and indicators etc. Allow a 5 minute warm-up period - longer for Thermocouples - refer following.
- (4) **All Inputs. Examples of Calibration.**  
Take a low reading of the variable being measured by the transducer supplying the signal to the XU2 and adjust the Zero Pot in the top of the XU2 enclosure until the correct reading is achieved on the PLC or indicator, etc, that the XU2 is connected into. Repeat until the desired accuracy is achieved.  
Note 1. Turn the Pot with a small screwdriver. Clockwise to increase the output reading and anti-clockwise to decrease the output reading.  
Note 2. For RTD and Thermocouple inputs that have previously been calibrated using certified calibration equipment only a Zero Pot adjustment is required. Refer below.

**DC Voltage and Current Input;** (a) Low reading suggest approx 10%, (b) High reading suggest approx 90% of the variable being measured by the transducer supplying the signal to the XU2.

**Potentiometer Inputs;** Due to cable resistance and errors within the potentiometer itself an error may occur (Usually less than 5%). (a) Low reading suggest move Potentiometer to 0% of its range. (b) High reading suggest move potentiometer to 100% of its range.

**RTD Inputs;** A small error can occur due to differences in cable resistance in the RTD legs, and errors in the RTD itself. (Usually less than 0.5°C). Place all the RTD probes into a calibrated thermal bath at the temperature interest or use a calibration standard RTD at the same immersion depth and temperature of interest and adjust the Zero Pot until the two temperatures agree.

**Thermocouple Inputs;** Due to the limits of error in a standard Thermocouple probe, and standard extension wire and compensating wire, an error can occur. E.g. In a type K Thermocouple installation an error of 2.2°C or 0.75% FSO can occur (whichever is greater). For low temperature Thermocouple measurement, the enclosure must be assembled and avoid drafts and temperature differences across terminals. Once installation is complete, close the cabinet door and allow the cabinet to reach equilibrium. This may take several hours. Place all the Thermocouple probes into a calibrated thermal bath at the temperature of interest or use a calibration standard Thermocouple at the same immersion depth and temperature of interest and adjust the Zero Pot until the two temperatures agree.

### XU2 Maintenance.

#### DC Voltage and Current and Potentiometer Inputs.

- (1) Check the Sensor or Transducer supplying the signal to the XU2 for wear or damage and replace if defective.
- (2) Check the cables connected to the Sensor or Transducer.
- (3) Repeat (4) of commissioning. Do it regularly - at least once every six months.

#### RTD Inputs.

- (1) Replace defective protection tubes - even if they look good they may not be air or gas tight.
- (2) Check cables entering the RTD sensor head.
- (3) Repeat (4) of commissioning. Do it regularly - at least once every six months.

#### Thermocouple Inputs.

- (1) Replace defective protection tubes - even if they look good they may not be air or gas tight.
- (2) Check extension and compensating cable circuits, especially cables entering the Thermocouple sensor head.
- (3) Do not use the same Chromel-Alumel (Type K) Thermocouple below 540°C if it was used above 860°C.
- (4) Repeat (4) of commissioning. Do it regularly - at least once a month.

<p style="text-align: center;"><b>Intech</b><sup>®</sup> Instruments</p> <p style="text-align: center;"><a href="http://www.intech.co.nz">www.intech.co.nz</a></p> <p>Christchurch Ph: +64 3 343 0646 Auckland Ph: 09 827 1930 Email: <a href="mailto:sales@intech.co.nz">sales@intech.co.nz</a></p>
--