

# General Purpose Data Logger

## Logger Model GP-HR mark 4

High Resolution (12 bit)  
Multi Purpose Data Logger.

The GP-HR is a small High Resolution (12 bit) multi purpose data logger housed in a rugged 19.05mm 304 stainless steel case, that can be configured to accept input from a wide variety of sources including:

- Current (DC) including 4~20mA
- Voltage (DC)
- Temperature\* Probes
- Wind Direction Sensors
- Wind Speed Probes
- Pressure Probes
- Flow Sensors
- Frequency
- Light Sensors
- Tipping Bucket Rain Gauges
- Leaf Wetness Sensor
- Solar Radiation Sensors
- Soil Water Tension Probes



Cable: **mA3+P-PS**  
(3x 4~20mA & 1x pulse inputs)

The GP-HR also has an internal temperature sensor for convenient logging of ambient temperature if desired. Logging can be configured to: start on time, immediate start, stop when full, loop around (overwrite oldest data).

**Ordering Information.** **GP-HR** General Purpose data logger.

**DLC3USB** [USB] download cable (2m) to connect GP-HR with computer.

### Standard Probes:

Standard probes and sets of probes, ready for plugging into the logger. Other combinations are also available.

- **mA1-PS** One 4~20mA or 0~20mA input.
- **mA3+P-PS** Three 4~20mA or 0~20mA inputs + One pulse input.
- **##VD3-PS** Three DC voltage inputs (specify voltage up to 32Vdc).
- **L-PS** Light/solar energy cable.
- **Pt3-PS** Three RTD Pt1000 temperature probes -50~130°C.
- **P###-HR-PS** Pressure probe ranges -15~100/300psi.
- **WS-PS** Anemometer 3 cup (wind speed).
- **WD-PS** Wind direction.
- **R-PS** Rain gauge.

### GP-HR mark 4 Dimensions.

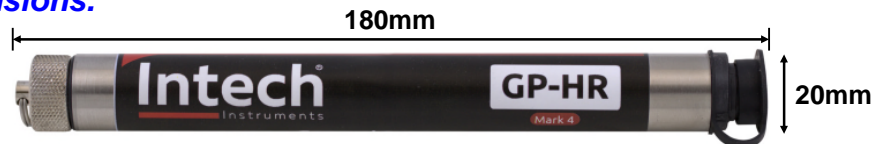

### Putting into service with Omni7 Data Management software.

1. From the SWDL-DLC Omni7 software and Download cable kit, **first install the Omni7 software**, then plug the Download cable into a spare USB [standard size] port on your computer (depending on which type you have). The Omni7 has an excellent "Help". This will need to be read to enable successful operation of the Omni7 Data Management Program and gain familiarisation of the many advanced features available.
2. Connect the data logger to the download cable. Select the correct connection type on the Omni7 screen. Omni7 requires manual connection and disconnection to the data logger using the Green 'Connect' and Red 'Disconnect' buttons. It will not connect to a data logger automatically. (Refer to "Help" for further assistance.)
3. On the "Logger Control" screen, click on "Channel and Probe Setup" button, and check the Battery Condition, plus other configurations.
4. Now click on the "Start Logger" tab for the final configurations, before putting the logger into service.

## Specifications.

External Sensor Connector:	Type	6 pin Switchcraft Plug (EN3C6M) Weatherproof; IP66
	Pinout	1 Switched Reference voltage 2 First Analogue Input 3 Second Analogue Input 4 Third Analogue Input 5 Fast Pulse Input 6 Common Ground

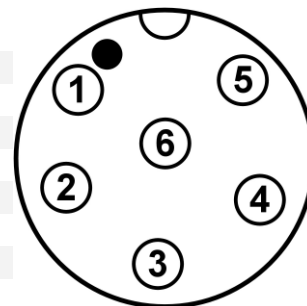

Three Analog Channels:	To log any combination of	Temperature Humidity Pressure Light Solar Energy	Wind Direction Soil Moisture Tension Leaf Wetness Voltage (DC) Current (DC)
------------------------	---------------------------	--	---

One Fast Pulse Digital Channel:	To log:	Rainfall Counter (up to 65535) Frequency (up to 60kHz)	Wind Speed Flow
---------------------------------	---------	--	--------------------

Internal Temperature:	Sensor Type	Thermister
	Linear accuracy over range	±0.3°C (0°C to 70°C)
	Repeatability	±0.1°C
	Long term stability	±0.1°C

Logger:	Working Temperature	-30°C to +70°C
	Storage Temperature	-30°C to +70°C
	Sampling Rate	1 second minimum, 10 hours maximum; in 1 second intervals
	Storage capacity	1,044,480 8 bit samples; 522,240 12 bit samples
		Over 600 days logging 3 Hi Resolution Channels every 5 minutes
	Alarms	Two independent Alarms Triggered on any combination of six user configurable Alarm Conditions Both alarms can be configured to send SMS messages Alarms can be visually checked using the Omni7 Software
	Start modes	Start immediately Start on date/time
	Stop modes	Stop when memory is full Stop on date/time
	Logging modes	Loop around (continues logging) Each channel can be set to log any combination of: - Point readings                      - Maximum reading - Average reading                      - Minimum reading
	<b>Warning:</b> When using the Average, Maximum or Minimum reading(s), the logger reads the attached sensor(s) every second. <b>This will reduce battery life.</b>	
	Battery	One to Five year life depending on usage as above Using the logger in temperatures below -5°C (23°F) will reduce battery life One 7.2Volt lithium cell; User Replaceable The data is retained in the case of battery failure Battery Status Monitor in Omni7 software
	Download time	9 minutes, 30 seconds for Full Logger
	Case material	304 Stainless tube
	Screw on end cap	Plated brass
	Weight	150g
	Size	20mm diameter X 180 mm long

A **DLC3USB [USB] or DLC3 [RS232] download cable (2m)** is required to connect the GP-HR to a computer.

**Product Liability.** This information describes our products. It does not constitute guaranteed properties and is not intended to affirm the suitability of a product for a particular application. Due to ongoing research and development, designs, specifications, and documentation are subject to change without notification. Regrettably, omissions and exceptions cannot be completely ruled out. No liability will be accepted for errors, omissions or amendments to this specification. Technical data are always specified by their average values and are based on Standard Calibration Units at 25C, unless otherwise specified. Each product is subject to the 'Conditions of Sale'.

**Warning: These products are not designed for use in, and should not be used for patient connected applications. In any critical installation an independent fail-safe back-up system must always be implemented.**

### Three Analogue Channels.

The three analogue channels have identical characteristics. Each channel can operate in two modes, Absolute and Ratiometric. The mode of operation is determined by the probe type selected for that channel. The probe type is selected using the Channel and Probe Setup Tab of the Logger Control Screen in the Omni7 Software. Using this software, a different Probe can be selected for each Channel. Temperature (Thermister), Pressure and Humidity probes are typically Ratiometric. Voltage and current inputs are Absolute.

Maximum readable input voltage in Ratiometric mode	3.3 Volts
Maximum readable input voltage in Absolute mode	2.048Volts
Maximum voltage input without damaging logger	5 Volts
Maximum current to be drawn by the combination of all three probes	5mA
Input Leakage Current	0.1uA

### One Fast Pulse Digital Channel.

The fast pulse input can be used in two modes, Counter or Frequency. Counter mode is used for functions such as rainfall. Frequency Mode is used for wind speed or flow sensors. The mode of operation is determined by the probe type selected for that channel. The probe type is selected using the Channel and Probe Setup Tab of the Logger Control screen in the Omni7 Software.

Maximum Count Per Logging Period	65535
Maximum Frequency with logging period set to 1sec	60kHz
Preferred Switch Input Type	Normally Open
Preferred Digital Input Type	Normally High
Minimum High Period	1uSec
Minimum Low Period	1uSec
Input Impedence	470 kOhm
Preferred voltage input	3.6 Volts
Maximum voltage input	5.0 Volts

### Standard Probe Sets.

- 1 External Temperature
- 2 External Temperature
- 3 External Temperature
- Humidity & Temperature Probe
- Humidity & Temperature Probe with additional Temperature Probe
- Pressure & Temperature Probe
- Pressure & Temperature Probe with additional Temperature Probe
- Light / Solar Energy Probe
- Light / Solar Energy Probe with additional Temperature Probe
- Tipping bucket rain Gauge Adaptor
- Tipping bucket rain Gauge Adaptor with additional Temperature Probe
- Wind Speed Anemometer
- Wind Speed Anemometer with Temperature Probe
- Leaf Wetness Probe
- Leaf Wetness Probe with additional Temperature Probe
- Breakout Adapter
- 1 input 0 to 20mA adapter (can be used with 4 to 20mA sensors)
- 2 input 0 to 20mA adapter (can be used with 4 to 20mA sensors)
- 3 input 0 to 20mA adapter (can be used with 4 to 20mA sensors)
- 3 input voltage Divider

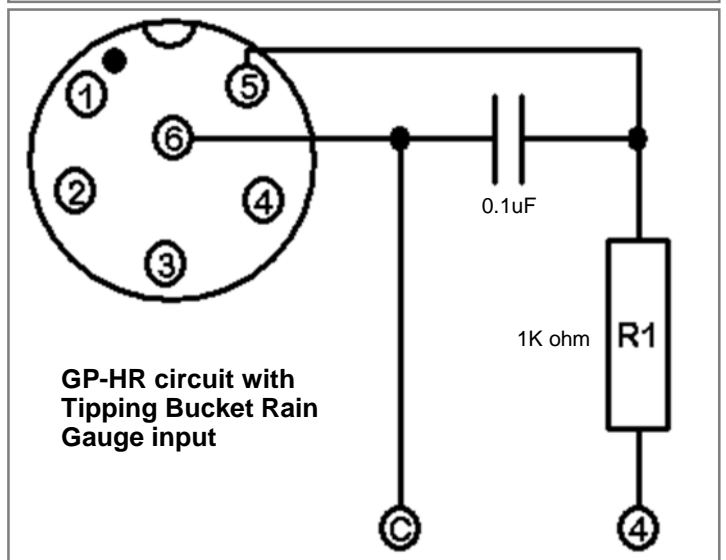
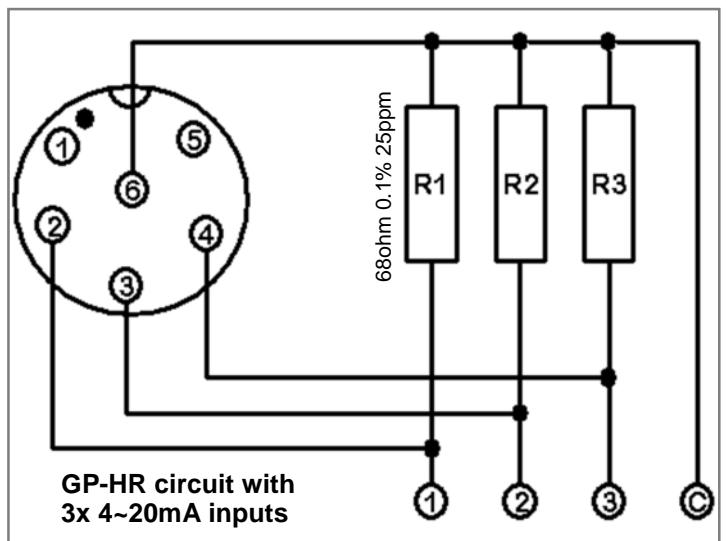

**\* Logging Thermocouple inputs with the GP-HR:**

A lot of people say thermocouple to mean temperature probes, where as if the temperature range they are measuring is between -50°C and +200°C, then **RTD Pt1000** is more accurate and cheaper to implement than thermocouple. Thermocouples are ideal for high temperature ranges.

The **Pt3-PS** probe set has three RTD Pt1000 temperature probes, ranged at -50~130°C for use with the GP-HR.

The only way that the GP-HR can accept a thermocouple signal is via an intermediary transmitter like the **XU Series** with an output signal of 4~20mA.

An **mA#-PS** adaptor cable for each input from the **XU Series** transmitter(s) to the GP-HR is also required (with the correct number of inputs [1~3]).

The **Tc-HR** or **Tc-LCD** data loggers are available for logging 1x Thermocouple input.

**Intech**<sup>®</sup>  
Instruments

[www.intech.co.nz](http://www.intech.co.nz)  
Christchurch Ph: +64 3 343 0646  
Auckland Ph: +64 9 827 1930  
Email: [sales@intech.co.nz](mailto:sales@intech.co.nz)