

# PI-N Programmable Isolating Differential RTD Transmitter.

Programmable Isolating Differential 2 Wire RTD Input to DC Current or DC Voltage Output Transmitter.

## Features.

- Field Programmable Input and Output Ranges.
- Bi-Polar Input and Output Ranges.
- Isolated Input to Output 1.6kV.
- High Accuracy & Linearity to 0.1%.
- Linear With Temperature.
- Universal AC/DC Power Supply.
- Compact DIN Rail Mount Enclosure.
- Available Standard or Special Calibration.



## Ordering Information.

PI-N-X Standard Calibration: Input 0~100C; Output 4~20mA; Upscale Break; High Voltage Power Supply.

PI-N -  -  -  -  - Special Range Special Range Calibration.  
IR OR SB PS

Other types of RTD available in special range calibration are JIS Pt100, Pt250, Pt500, Pt1000, CU10, CU100, Ni100 or specify.

Other PI- models include:  
 PI-B Bridge / Strain gauge;  
 PI-D DC; mA, mV, V.  
 PI-F Frequency;  
 PI-K Resistance;  
 PI-M Maths Computing;  
 PI-N RTD Differential Pt100;  
 PI-P Potentiometer;  
 PI-R RTD Pt100;  
 PI-S Relay Dual Setpoint;  
 PI-T Thermocouple.

INPUT RANGES (DIN PT100)								OUTPUT RANGES				Sensor Break	
deg C	IR	deg C	IR	deg F	IR	deg F	IR	Voltage	OR	Current	OR	State	SB
0~20C	1	-10~10C	21	0~40F	41	-20~20F	61	0~500mV	A	0~1mA	1	Upscale	US
0~25C	2	-10~20C	22	0~50F	42	-20~40F	62	0~1V	B	0~2mA	2	Downscale	DS
0~30C	3	-10~40C	23	0~60F	43	-20~80F	63	0~2V	C	0~5mA	3		
0~40C	4	-20~20C	24	0~80F	44	-40~40F	64	0~3V	D	0~10mA	4		
0~50C	5	-20~30C	25	0~100F	45	-40~60F	65	0~4V	E	0~16mA	5		
0~60C	6	-25~25C	26	0~120F	46	-50~50F	66	0~5V	F	0~20mA	6		
0~70C	7	-25~50C	27	0~140F	47	-50~100F	67	0~6V	G	1~5mA	7		
0~75C	8	-30~20C	28	0~150F	48	-60~40F	68	0~8V	H	2~10mA	8		
0~80C	9	-50~50C	29	0~160F	49	-100~100F	69	0~10V	I	4~20mA	9		
0~90C	10	-50~100C	30	0~180F	50	-100~200F	70	0~12V	J	-1~1mA	10		
0~100C	11	-50~150C	31	0~200F	51	-100~300F	71	1~5V	K	-2~2mA	11		
0~110C	12	-100~100C	32	0~220F	52	-200~200F	72	2~10V	L	-5~5mA	12		
0~120C	13	-100~200C	33	0~240F	53	-200~400F	73	-1~1V	M	-10~10mA	13		
0~125C	14	-200~200C	34	0~250F	54	-400~400F	74	-2~2V	N	-20~20mA	14		
0~150C	15	-200~400C	35	0~300F	55	-400~800F	75	-5~5V	O				
0~200C	16	20~40C	36	0~400F	56	40~80F	76	-10~10V	P				
0~250C	17	50~100C	37	0~500F	57	100~200F	77	-12~12V	Q				
0~300C	18	50~150C	38	0~600F	58	100~300F	78						
0~400C	19	100~200C	39	0~800F	59	200~400F	79						
0~600C	20	100~500C	40	0~1200F	60	200~1000F	80						
Special Input Range			Z	Special Input Range			Z	Special Output Range			Z		

POWER SUPPLY		PS
High Voltage Power Supply: 85~264Vac/dc		H
Mid Voltage Power Supply: 22~85Vac/dc		M
Low Voltage Power Supply: 10~28Vac/dc		L

Note: Power supply H is field selectable for M, and M for H. Power supply L must be ordered separately.

## Ordering Examples.

- 1/ PI-N-5-1-L 0~50C Input; 0~1mA Out; Upscale Break; Low Voltage Power Supply.
- 2/ PI-N-Z-P-H-CU10-0/150C CU10 0~150C In; -10~10V Out; Upscale Break; High Voltage Power Supply.

## Quality Assurance Programme.

The modern technology and strict procedures of the ISO9001 Quality Assurance Programme applied during design, development, production and final inspection grant long term reliability of the instrument.

# PI-N Rev2 Specifications.

RTD Input	Pt100 DIN (2 Wire Type) Standard. Sensor Current = 0.8mA Typical. Field Programmable Zero From -200C(-400F) to 200C(400F). Field Programmable Span From 20C(40F) to 600C(1200F). Other Types of RTD Available: JIS Pt100, Pt250, Pt500, Pt1000, CU10, CU100, Ni100 or Specified.
Output - Voltage	Field Programmable From 500mVdc to ±12Vdc. Maximum Output Drive = 10mA.
- Current	Field Programmable From 1mAdc to ±20mAdc. Maximum Output Drive = 10Vdc. (500Ω @ 20mA.)
Power -H	85~264Vac/dc; 50/60Hz; 5VA.
-M	22~85Vac/dc; 50/60Hz; 5VA.
-L	10~28Vac/dc; 50/60Hz; 5VA.
-Circuit Sensitivity	<±0.001%/V FSO Typical.
Accurate to	<±0.1% FSO Typical.
Linearity & Repeatability	<±0.1% FSO Typical.
Ambient Drift	<±0.01%/C FSO Typical.
Noise Immunity	125dB CMRR Average. (1600Vdc Limit.)
EMC Compliances	Emissions EN 55022-A. Immunity EN 50082-1, <1% Effect FSO Typical.
Safety Compliance	EN 60950
Mains Isolation	250Vac.
Isolation Test Voltages	Mains to Input/Output 3kVac 50Hz for 1min; Input to Output 1.6kVdc for 1min.
Response Time	200msec Typical. (10 to 90% 50msec Typical.)
Operating Temperature & Humidity	0~60C. (Storage Temp. -20~80C.) 5~85% RH Max. Non-Condensing.
Dimensions and Mounting	L=80, W=50, H=120mm. Mounts on 35mm Symetrical Mounting Rail.

**Product Liability.** This information describes our products. It does not constitute guaranteed properties and is not intended to affirm the suitability of a product for a particular application. Due to ongoing research and development, designs, specifications, and documentation are subject to change without notification. Regrettably, omissions and exceptions cannot be completely ruled out. No liability will be accepted for errors, omissions or amendments to this specification. Technical data are always specified by their average values and are based on Standard Calibration Units at 25C, unless otherwise specified. Each product is subject to the 'Conditions of Sale'.

**Warning: These products are not designed for use in, and should not be used for patient connected applications. In any critical installation an independant fail-safe back-up system must always be implemented.**

## Examples of Input Connection.

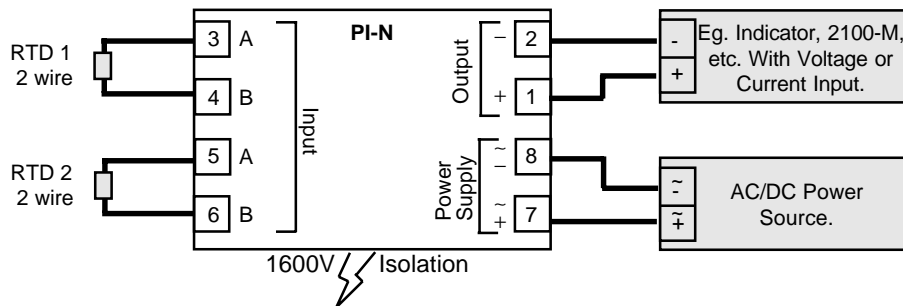

## Terminations.

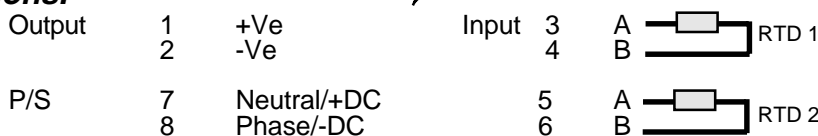

## Plan View of PI-N Adjustments.

OUTPUT PROGRAMMING | INPUT PROGRAMMING

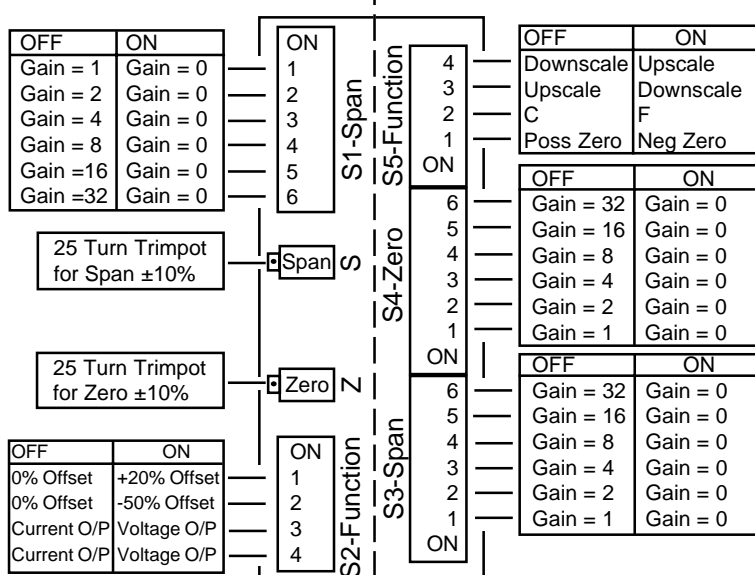

## PI-N Dimensions and Mounting.

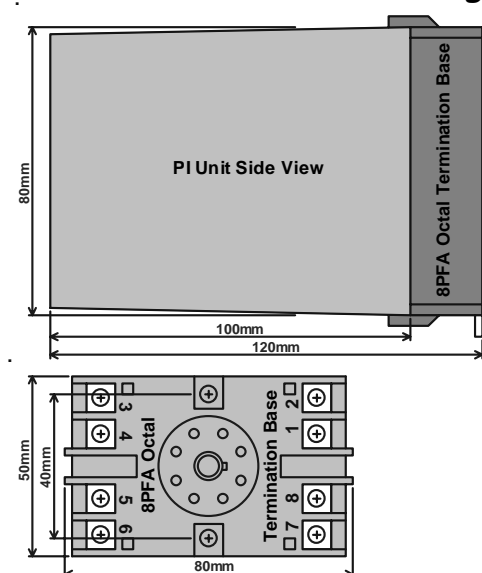

### PI-N Input Programming.

Always set **OUTPUT range first**, then INPUT range.

If the Input range is not listed in the programming table, use the following formulae to work out the Zero and Span DIP switch settings for gain.

$$\text{Deg C Span Gain} = \frac{1200}{\text{deg C High} - \text{deg C Low}}$$

$$\text{Deg F Span Gain} = \frac{2400}{\text{deg F High} - \text{deg F Low}}$$

$$\text{Deg C Zero Gain} = \frac{\text{deg C Low}}{5}$$

$$\text{Deg F Zero Gain} = \frac{\text{deg F Low}}{10}$$

If Zero is: 1/ Positive, put S5-1 OFF. 2/ Negative, put S5-1 ON.

Gain Value	1	2	4	8	16	32
DIP Switch No.	1	2	3	4	5	6

So if a gain value of 28 is required, put DIP switch No's 3, 4, 5 OFF (ie, gains of 4 + 8 + 16 = 28) and all the other DIP switches ON.

DIP switches and Pots are accessed by removing the small rectangular lid on the top of the PI-N enclosure

- Note:** (a) Enter the Zero or Span gain value into the appropriate Zero or Span DIP switch.  
 (b) If the ZERO GAIN exceeds **63**, then the input range must be factory calibrated.

### PI-N Input Range Programming Table.

- Notes:** 1/ Switch status 1 = ON, 0 = OFF, X = DON'T CARE.  
 2/ Input ranges with '\*' beside them require more adjustment by the Span trimpot.

Input Range C Put S5-2 OFF	Input Range F Put S5-2 ON	S3-Span						S4-Zero						S5-Function						
		1	2	3	4	5	6	1	2	3	4	5	6	1	2	3	4			
0~20C	0~40F	1	1	0	0	0	0	1	1	1	1	1	1	X	SET TO '0' FOR CELCIUS. SET TO '1' FOR FAHRENHEIT.	Set to '0' for UPSCALE Sensor Break. Set to '1' for DOWNSCALE Sensor Break.	Set to '1' for UPSCALE Sensor Break. Set to '0' for DOWNSCALE Sensor Break.			
0~25C	0~50F	1	1	1	1	0	0	1	1	1	1	1	1	X						
0~30C	0~60F	1	1	1	0	1	0	1	1	1	1	1	1	X						
0~40C	0~80F	1	0	0	0	0	1	1	1	1	1	1	1	X						
0~50C	0~100F	1	1	1	0	0	1	1	1	1	1	1	1	X						
0~60C	0~120F	1	1	0	1	0	1	1	1	1	1	1	1	X						
0~70C *	0~140F *	0	1	1	1	0	1	1	1	1	1	1	1	X						
0~75C	0~150F	1	1	1	1	0	1	1	1	1	1	1	1	X						
0~80C	0~160F	0	0	0	0	1	1	1	1	1	1	1	1	X						
0~90C	0~180F	0	1	0	0	1	1	1	1	1	1	1	1	X						
0~100C *	0~200F *	1	1	0	0	1	1	1	1	1	1	1	1	X						
0~110C	0~220F	0	0	1	0	1	1	1	1	1	1	1	1	X						
0~120C	0~240F	1	0	1	0	1	1	1	1	1	1	1	1	X						
0~125C *	0~250F *	1	0	1	0	1	1	1	1	1	1	1	1	X						
0~150C	0~300F	1	1	1	0	1	1	1	1	1	1	1	1	X						
0~200C	0~400F	1	0	0	1	1	1	1	1	1	1	1	1	X						
0~250C *	0~500F *	0	1	0	1	1	1	1	1	1	1	1	1	X						
0~300C	0~600F	1	1	0	1	1	1	1	1	1	1	1	1	X						
0~400C	0~800F	0	0	1	1	1	1	1	1	1	1	1	1	X						
0~600C	0~1200F	1	0	1	1	1	1	1	1	1	1	1	1	X						
-10~10C	-20~20F	1	1	0	0	0	0	1	0	1	1	1	1	1						
-10~20C	-20~40F	1	1	1	0	1	0	1	0	1	1	1	1	1						
-10~40C	-20~80F	1	1	1	0	0	1	1	0	1	1	1	1	1						
-20~20C	-40~40F	1	0	0	0	0	1	1	1	0	1	1	1	1						
-20~30C	-40~60F	1	1	1	0	0	1	1	1	0	1	1	1	1						
-25~25C	-50~50F	1	1	1	0	0	1	0	1	0	1	1	1	1						
-25~50C	-50~100F	1	1	1	1	0	1	0	1	0	1	1	1	1						
-30~20C	-60~40F	1	1	1	0	0	1	1	0	0	1	1	1	1						
-50~50C	-100~100F	1	1	0	0	1	1	1	0	1	0	1	1	1						
-50~100C	-100~200F	1	1	1	0	1	1	1	0	1	0	1	1	1						
-50~150C	-100~300F	1	0	0	1	1	1	1	0	1	0	1	1	1						
-100~100C	-200~200F	1	0	0	1	1	1	1	1	0	1	0	1	1						
-100~200C	-200~400F	1	1	0	1	1	1	1	1	0	1	0	1	1						
-200~200C	-400~400F	0	0	1	1	1	1	1	1	1	0	1	0	1						
-200~400C	-400~800F	1	0	1	1	1	1	1	1	1	0	1	0	1						
20~40C	40~80F	1	1	0	0	0	0	1	1	0	1	1	1	0						
50~100C	100~200F	1	1	1	0	0	1	1	0	1	0	1	1	0						
50~150C	100~300F	1	1	0	0	1	1	1	0	1	0	1	1	0						
100~200C	200~400F	1	1	0	0	1	1	1	1	0	1	0	1	0						
100~500C	200~1000F	0	0	1	1	1	1	1	1	0	1	0	1	0						

## PI-N H1 Power Supply Jumper Settings.

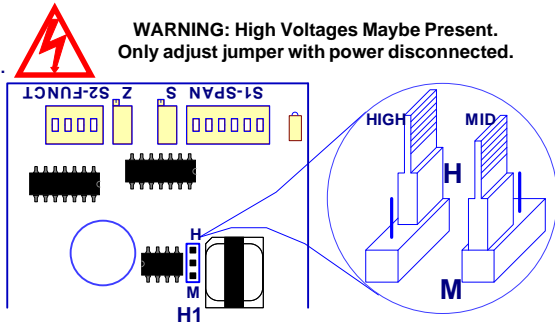

Power Supply Jumper Settings	
H1	Power Supply Voltage Range
H	Link for High: 85~264Vac/dc
M	Link for Mid: 22~85Vac/dc

### Notes:

- 1/ H1 is approx 4cm (1½") behind the 'S' trimpot.
- 2/ Exceeding voltage ranges may damage the unit.
- 3/ Ensure the enclosure label is correctly labelled for the jumper position.
- 4/ Adjust H1 jumper with a pair of needle nose pliers.
- 5/ Low Voltage Power Supply version is fixed, and has no jumper. This must be ordered separately.

## Output Range Programming Table.

- Notes:
- 1/ Switch status 1 = ON 0 = OFF.
  - 2/ Output ranges with '\*' beside them reverse the polarity of the output connections.

Output Range (V)	S1-SPAN						S2-Function				Output Range (I)	S1-SPAN						S2-Function			
	1	2	3	4	5	6	1	2	3	4		1	2	3	4	5	6	1	2	3	4
0~500mV	0	1	1	1	1	1	0	0	1	1	0~1mA	0	1	1	1	1	1	0	0	0	0
0~1V	1	0	1	1	1	1	0	0	1	1	0~2mA	1	0	1	1	1	1	0	0	0	0
0~2V	1	1	0	1	1	1	0	0	1	1	0~5mA	0	1	0	1	1	1	0	0	0	0
0~3V	1	0	0	1	1	1	0	0	1	1	0~10mA	1	0	1	0	1	1	0	0	0	0
0~4V	1	1	1	0	1	1	0	0	1	1	0~16mA	1	1	1	1	0	1	0	0	0	0
0~5V	1	0	1	0	1	1	0	0	1	1	0~20mA	1	1	0	1	0	1	0	0	0	0
0~6V	1	1	0	0	1	1	0	0	1	1	1~5mA	1	1	0	1	1	1	1	0	0	0
0~8V	1	1	1	1	0	1	0	0	1	1	2~10mA	1	1	1	0	1	1	1	0	0	0
0~10V	1	1	0	1	0	1	0	0	1	1	4~20mA	1	1	1	1	0	1	1	0	0	0
0~12V	1	1	1	0	0	1	0	0	1	1	-1~1mA	1	0	1	1	1	1	0	1	0	0
1~5V	1	1	1	0	1	1	1	0	1	1	-2~2mA	1	1	0	1	1	1	0	1	0	0
2~10V	1	1	1	1	0	1	1	0	1	1	-5~5mA	1	0	1	0	1	1	0	1	0	0
-1~1V	1	1	0	1	1	1	0	1	1	1	-10~10mA	1	1	0	1	0	1	0	1	0	0
-2~2V	1	1	1	0	1	1	0	1	1	1	-20~20mA	1	1	1	0	1	0	0	1	0	0
-5~5V	1	1	0	1	0	1	0	1	1	1	0~-10mA *	1	0	1	0	1	1	0	0	0	0
-10~10V	1	1	1	0	1	0	0	1	1	1	0~-20mA *	1	1	0	1	0	1	0	0	0	0
-12~12V	1	1	1	1	0	0	0	1	1	1											
0~-5V *	1	0	1	0	1	1	0	0	1	1											
0~-10V *	1	1	0	1	0	1	0	0	1	1											

## The Proper Installation & Maintenance of PI-N.

Note. All power and signals must be de-energised before connecting any wiring, altering any jumpers or DIP switches, or inserting or removing the PI unit from its base.

### MOUNTING.

- (1) Mount in a clean environment in an electrical cabinet on 35mm, symmetrical, mounting rail.
- (2) Draft holes must have minimum free air space of 20mm. Foreign matter must not enter or block draft holes.
- (3) Do not subject to vibration or excess temperature or humidity variations.
- (4) Avoid mounting in cabinets with power control equipment.
- (5) To maintain compliance with the EMC Directives the PI-N is to be mounted in a fully enclosed steel cabinet. The cabinet must be properly earthed, with appropriate input / output entry points, filtering and cabling.

### WIRING.

- (1) A readily accessible disconnect device and a 1A, 250Vac overcurrent device, must be in the power supply wiring.
- (2) All cables should be good quality overall screened INSTRUMENTATION CABLE with the screen earthed at one end only.
- (3) Signal cables should be laid a minimum distance of 300mm from any power cables.
- (4) For 2 wire current loops and 2 wire RTDs, Austral Standard Cables B5102ES is recommended. For three wire transmitters and 3 wire RTDs Austral Standard Cables B5103ES is recommended.
- (5) For differential 2-wire RTD measurement it is important to use identical cables and keep them the same length, so errors due to cable length are kept minimal.
- (6) It is recommended that you do not ground current loops and use power supplies with ungrounded outputs.
- (7) Lightning arrestors should be used when there is a danger from this source.
- (8) Refer to diagrams for connection information.

### RTD'S.

- (1) Avoid locating the RTD where it will be in a direct flame.
- (2) Locate it where the average temperature will be measured. It should be representative of the mass.
- (3) Immerse the RTD so that the measuring point is entirely in the temperature to be measured; 9 to 10 times the diameter of the protection tube is recommended. Heat that is conducted away from the measuring point causes an error in reading.

### COMMISSIONING.

- (1) Once all the above conditions have been carried out and the wiring checked apply power to the PI-N loop and allow five minutes for it to stabilize.
- (2) Due to differences in cable resistance in the RTD legs or errors within the RTD itself a small Zero error may occur (usually less than 1C). To remove this error use two calibration standard RTDs at the same immersion depths and adjust the Zero Pot in the top of the PI-N enclosure with a small screwdriver, until the two levels agree. (Clockwise to increase the output reading and anti-clockwise to decrease the output reading.)

### MAINTENANCE.

- (1) Check RTDs in place - with the calibration RTDs at the same immersion depths.
- (2) Do it regularly - at least once every 6 months.
- (3) Replace defective protection tubes - even if they look good they may not be fluid or gas tight.
- (4) Check cables entering the RTD sensor heads.

**Intech INSTRUMENTS LTD**  
[www.intech.co.nz](http://www.intech.co.nz)  
 Christchurch Ph: +64 3 343 0646  
 Auckland Ph: 09 827 1930  
 Email: [sales@intech.co.nz](mailto:sales@intech.co.nz)