

LPI-CT AC Current Transmitter.

Isolating AC Current Input to 4~20mA Output Loop Powered Transmitter.

Features.

- Field Programmable 1Aac or 5Aac.
- Mains Isolated.
- High Accuracy.
- Reverse Polarity Protected.
- LED Indication of Current Loop (CL).
- Compact DIN Rail Mount Enclosure.
- 40~200mV Output Test Signal.
- Easy to Install.
- Low Cost .
- Wide P/S Range.
- Available With One or Two Transmitters per Enclosure.

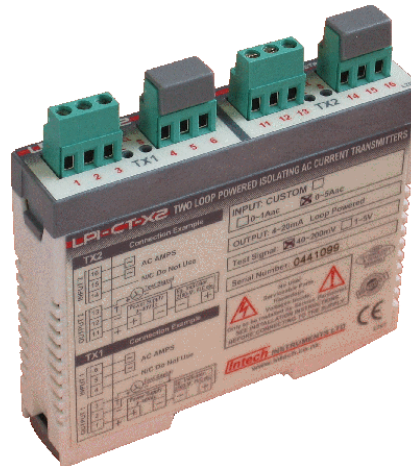

Other LPI- models include:
 LPI-B :Bridge / Strain gauge;
 LPI-D :DC;
 LPI-K :Resistance;
 LPI-N :Differential Pt100 RTD;
 LPI-P :Potentiometer;
 LPI-R :Pt100 RTD;
 LPI-T :Thermocouple;
 LPI-DO2 :DO2, LCD Display;
 LPI-ORP :ORP, LCD Display;
 LPI-pH :pH, LCD Display.

Ordering Information.

LPI-CT-X1-1 Special Calibration. 0~1Aac Input Range.

LPI-CT-X1-5 Standard Calibration. 0~5Aac Input Range.

LPI-CT- - Special Calibration.
 EN A

ENCLOSURE (EN)		Input Current Range (Aac)	
X1	DIN Rail Mount; 1Tx. L=100, W=22.5, H=100mm	1	0~1Aac
X2	DIN Rail Mount; 2Tx. L=100, W=22.5, H=100mm	5	0~5Aac
		Specify	Specify within 0~5Aac Range.

Note: For LPI-CT-X2 BOTH Transmitters are supplied with the same range.

Ordering Example.

LPI-CT-X1-1 LPI-CT; DIN Rail Enclosure L=100, W=22.5, H=100mm; One Transmitter in one enclosure; 0~1Aac Input Range; Loop Powered 4~20mA Output.

LPI-CT-X2-5 LPI-CT; DIN Rail Enclosure L=100, W=22.5, H=100mm; Two Transmitters in one enclosure; 0~5Aac Input Range; Loop Powered 4~20mA Output.

LPI-CT-X1-200mA LPI-CT; DIN Rail Enclosure L=100, W=22.5, H=100mm; One Transmitter in one enclosure; Special Calibration 0~200mA Input Range; Loop Powered 4~20mA Output.

Quality Assurance Programme.

The modern technology and strict procedures of the ISO9001 Quality Assurance Programme applied during design, development, production and final inspection grant long term reliability of the instrument. This instrument has been designed and built to comply with EMC and Safety Standards requirements.

LPI-CT Specifications.

Input	-Current	0~1Aac or 0~5Aac; 50/60Hz.
	-Input DC Resistance	0.01Ω Maximum
	-Maximum Over-range	10Aac Continuous.
Output	-mA	2 wire 4~20mA. (Loop Powered.)
	-mV Test	40~200mV ±1% ∞ 4~20mA. Other Test Voltages Available. e.g. 1~5V. Note. mV Test Increases Power Supply & Decreases Load Resistance.
Power Supply		9~33Vdc.
Supply Voltage Sensitivity		<±0.01%/V FSO.
Output Load Resistance		750Ω @ 24Vdc. (50Ω/V Above 9Vdc.)
Maximum Output Current		Limited to <30mA.
EMC Emissions Compliance		EN 55022-A
EMC Immunity Compliance		EN 50082-1
Safety Compliance.		EN 60950
Mains Isolation.		300Vac.
Isolation Test Voltages		-AC Input to Output; 3000Vac 50Hz for 1 min.
		-Between 2 LPI-CT-X2 Units; 3000Vac 50Hz for 1 min.
Linearity and Accurate to		<±0.5% FSO Typical.
Repeatability		<±0.1% FSO Typical.
Ambient Drift		<±0.02%/C FSO Typical.
R.F. Immunity		<1% Effect FSO Typical.
Response Time		2sec Typical.
Operating Temperature		0~70C.
Storage Temperature		-20~80C.
Operating Humidity		5~85%RH Max. Non-Condensing.
Weight		LPI-CT-X1; 130g. LPI-CT-X2; 170g.
Dimensions		L=100, W=22.5, H=100mm.

Product Liability. This information describes our products. It does not constitute guaranteed properties and is not intended to affirm the suitability of a product for a particular application. Due to ongoing research and development, designs, specifications, and documentation are subject to change without notification. Regrettably, omissions and exceptions cannot be completely ruled out. No liability will be accepted for errors, omissions or amendments to this specification. Technical data are always specified by their average values and are based on Standard Calibration Units at 25C, unless otherwise specified. Each product is subject to the 'Conditions of Sale'.

Warning: These products are not designed for use in, and should not be used for patient connected applications. In any critical installation an independent fail-safe back-up system must always be implemented.

Top Overview of LPI-CT-X2 Terminals.

(Two Transmitters per enclosure.)

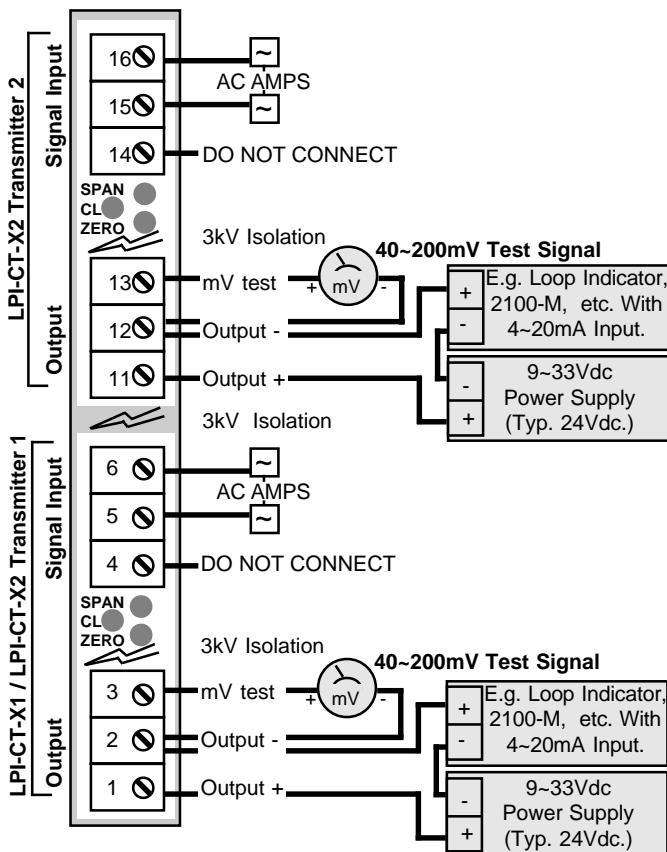

LPI-CT-X1 Terminations.

Input		Output	
6	AC IN	3	mV Test
5	AC IN	2	-mA Output
4	N/C	1	+mA Output

LPI-CT-X2 Terminations.

TX1 Input		TX1 Output	
6	AC IN	3	mV Test
5	AC IN	2	-mA Output
4	N/C	1	+mA Output

TX2 Input		TX2 Output	
16	AC IN	13	mV Test
15	AC IN	12	-mA Output
14	N/C	11	+mA Output

LPI-CT-D Input Connection Examples.

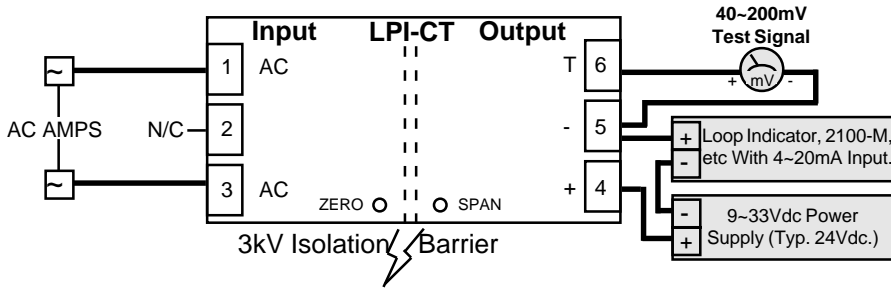

LPI-CT-D Terminations.

Input	1	AC IN
	2	N/C
	3	AC IN
Output	4	+mA Output
	5	-mA Output
	6	mV TEST

Plan View of LPI-CT-X Adjustments.

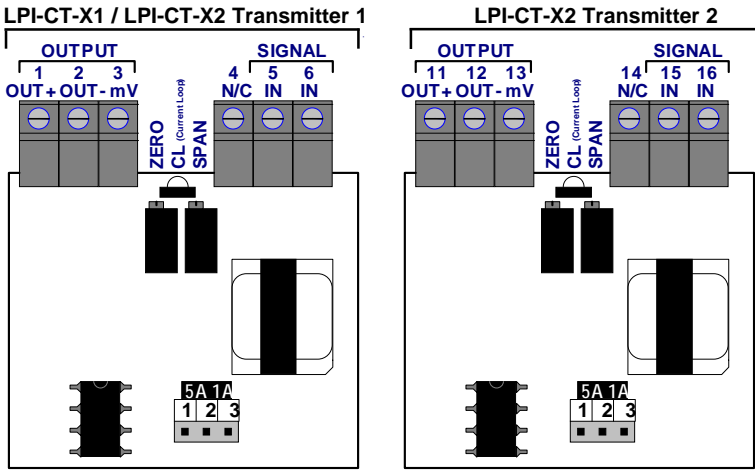

Plan View of LPI-CT-D Adjustments.

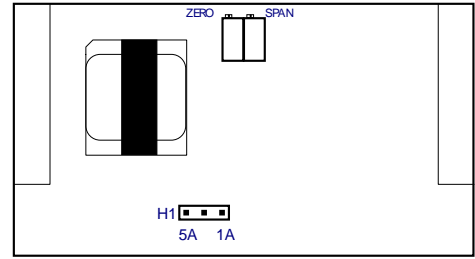

LPI-CT-X Enclosure Dimensions.

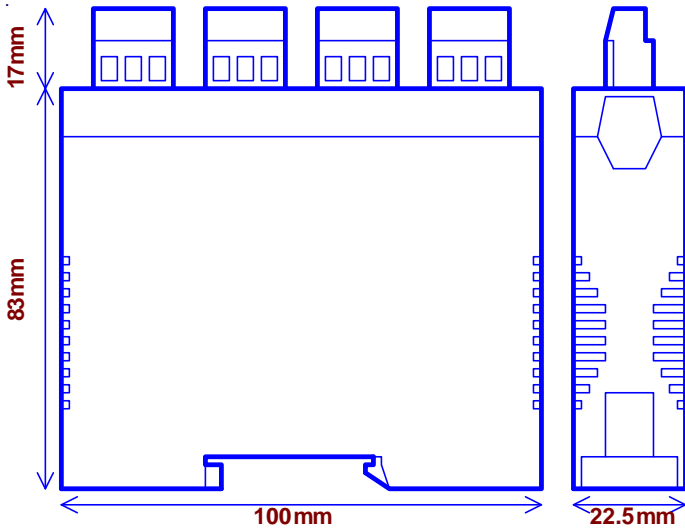

LPI-CT-D Enclosure Dimensions.

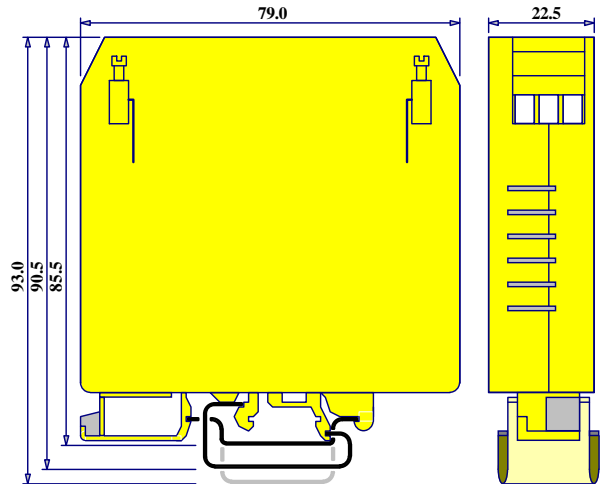

LPI-CT Input Programming Table.

H1 AC Current Input Programming	
Input Range	H1 Position
1Aac	Jumper 1A
5Aac	Jumper 5A

Note: Do not adjust H2 'CAL'

Maximum Load Vs Power Supply.

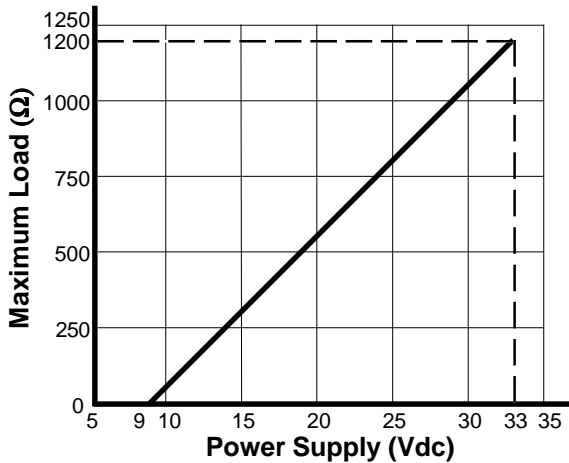

The Proper Installation & Maintenance of LPI-CT.

All power and signals must be de-energised before connecting any wiring, or altering any Jumpers or Dip Switches.

MOUNTING.

- (1) Mount in a clean environment in an electrical cabinet on 35mm Symmetrical mounting rail.
- (2) Do not subject to vibration or excess temperature or humidity variations.
- (3) Draft holes must have minimum free air space of 20mm. Foreign matter must not enter or block draft holes.
- (4) Avoid mounting in cabinets with power control equipment.
- (5) To maintain compliance with the EMC Directives the LPI-CT is to be mounted in a fully enclosed steel cabinet. The cabinet must be properly earthed, with appropriate input / output entry points and cabling.
- (6) Allow 10mm minimum clearance between the LPI-CT terminals and ANY conductive material.

Cover Removal and Fitting.

To remove the PCB to access jumpers and dip switches, push in the GREY BUTTONS at both ends of the enclosure TOP, and slide the PCB from the BASE of the enclosure. To reassemble slide the PCB back into the BASE until both GREY BUTTONS 'snap' into place. Ensure the TOP of the enclosure is flush with the BASE on all sides.

INPUT WIRING.

- (1) Use mains rated cable capable of carrying a minimum of 10A continuously, at the operating temperature.
- (2) Keep the mains power cables a minimum distance of 300mm from any signal cables.
- (3) Refer to diagrams for connection information.
- (4) To ensure compliance to CE Safety requirements, the grey terminal insulator must be fitted to ALL mains terminals after wiring is completed.

OUTPUT WIRING.

- (1) All cables should be good quality overall screened INSTRUMENTATION CABLE with the screen earthed at one end only.
- (2) Signal cables should be laid a minimum distance of 300mm from any power cables.
- (3) For 2 wire current loops and 2 wire voltage signals or 2 wire current signals, Austral Standard Cables B5102ES is recommended. For 3 wire transmitters Austral Standard Cables B5103ES is recommended.
- (4) It is recommended that you do not ground current loops and use power supplies with ungrounded outputs.
- (5) Lightning arrestors should be used when there is a danger from this source.
- (6) Refer to diagrams for connection information.

COMMISSIONING.

- (1) Once all the above conditions have been carried out and the wiring checked apply power to the LPI-CT loop and allow five minutes for it to stabilize.
- (2) Take a low (approx. 10%) and high (approx. 90%) reading of the variable being measured by the transducer supplying the signal to the LPI-CT, and ensure that this agrees with the level being indicated by the PLC or indicator, etc, that the LPI-CT is connected into. Adjust for any difference using the Zero & Span Pots in the top of the LPI-CT enclosure with a small screw driver, until the two levels agree. (Clockwise to increase the output reading and anti-clockwise to decrease the output reading.)

MAINTENANCE.

- (1) Repeat (2) of Commissioning.
- (2) Do it regularly - at least once every 12 months.

Intech INSTRUMENTS LTD
www.intech.co.nz
Christchurch Ph: +64 3 343 0646
Auckland Ph: 09 827 1930
Email: sales@intech.co.nz