

TruTrack Data Logger

General Purpose Multi Channel Logger Model GP-MC

High Resolution (12 bit)
Multi Purpose Data Logger.

The **GP-MC** is a high resolution (12 bit) multi purpose Data Logger with eight analog and two digital pulse inputs. It supports an additional 15 channels of input from remote sensors on an RS485 interface. It also provides a Start on Trigger input and two alarm outputs. The GP-MC can be supplied in an optional IP66 Weatherproof enclosure if required. It can be configured to accept input from a wide variety of sources including:

- Pt1000 Temperature Probes
- 4-20mA
- Voltage (DC)
- Current (DC)
- Pressure Probes
- Potentiometers
- Flow Sensors
- Frequency
- Tipping Bucket Rain Gauges
- Solar Radiation Sensors
- Light Sensors
- Leaf Wetness Sensor
- Soil Water Tension Probes
- Wind Speed Probes
- Wind Direction Sensors
- Switches

Each logged input requires conditioning using a 'Probe Set'.



The GP-MC also has an internal temperature sensor for convenient logging of ambient temperature if desired. Logging can be configured to: start on time, immediate start, stop when full, loop around (overwrite oldest data).

GP-MC Dimensions:

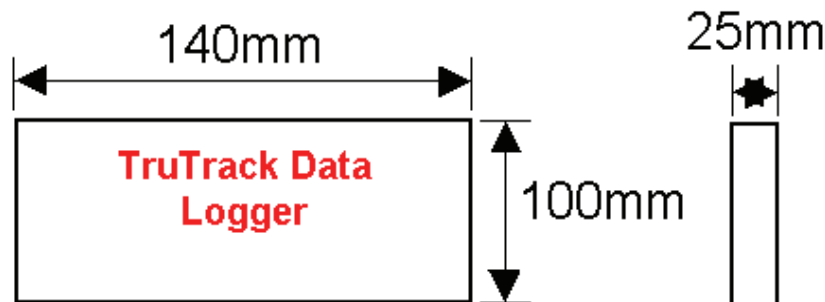

Putting into service:

1. From the SWDL-DLC OmniLog software and Download cable kit, **first install the OmniLog software**, then plug the Download cable into a spare USB or serial port on your PC (depending on which type you have). The OmniLog has an excellent "Help". This will need to be read to enable successful operation of the OmniLog Data Management Program and gain familiarisation of the many advanced features available.
2. Connect the TruTrack Logger. Under healthy circumstances, a "Logger Control" screen will load. If the "Logger Control" screen does not load, click on the button labelled "Connect to a Logger for the first time". The OmniLog will run a test on the serial ports and advise if the port the logger is connected to is not available, in which case, plug the logger into an available port. (Refer to "Help" for further assistance.)
3. On the "Logger Control" screen, click on "Channel and Probe Setup" button, and check the Battery Condition, plus other configurations if connecting to the pH-HR or mV-HR loggers.

Now click on the "Start Logger" tab for the final configurations, before putting the logger into service.

Specifications:

External Connectors:	Type	4 x 4way terminal block for eight analog inputs 1 x 4way terminal block for two digital pulse inputs 1 Female 9pinD for RS232 Communications 1 x 5way terminal block for two Alarm outputs and one Trigger input 1 x 4way terminal block for RS485 interface to remote probes
Eight Analog Channels:	To log any combination of	Temperature Voltage (DC) Humidity Current (DC) including 4~20mA Pressure Leaf Wetness Wind Direction Soil Moisture Tension Light Solar Energy
One Fast Pulse Digital Channel:	To log:	Flow Frequency (up to 60kHz) Wind Speed Counter (up to 65535)
One Slow Pulse Digital Channel:	To log:	Slow Counter (up to 65535) Low Frequency (up to 10Hz) Slow Flow (up to 10 pulses per sec) Rainfall
Internal Temperature:	Sensor Type	Thermister
	Linear accuracy over range	±0.3°C (0°C to 70°C)
	Repeatability	±0.1°C
	Long term stability	±0.1°C
Logger:	Working Temperature	-30°C to +70°C
	Storage Temperature	-30°C to +70°C
	Sampling Rate	1 second minimum, 10 hours maximum; in 1 second intervals
	Storage capacity	1,000,000 8 bit samples; 500,000 12 bit samples
	Alarms	Two independent Alarms Triggered on any combination of six user configurable Alarm Conditions One alarm can be configured to dial a PocketPager Alarms can be visually checked using the OmniLog Software
	Start modes	Start immediately Start on date/time Start on Trigger (Trigger input line) Start on Condition (Start when a selected channel meets a condition)
	Stop modes	Stop when memory is full Stop on date/time
	Logging modes	Loop around (continues logging) Each channel can be set to log any combination of: - Point readings - Maximum reading - Average reading - Minimum reading
	Battery	One to Five year life depending on usage One AA 3.6V lithium cell; User Replaceable The data is retained in the case of battery failure Battery Status Monitor in OmniLog software
	External Power Input	5V to 15V DC Plug Pack or Battery Internal battery runs logger if External Power fails Can be used to run logger while internal battery is charged Used when large current draw from probes would flatten Internal Battery Used at very low temperature (< 10°C) where Internal Battery voltage can drop External Power Status Monitor in OmniLog software
	Download time	16 minutes for Full Logger
	Case material	PVC
	IP Rating	GP-MC for indoor use only IP54 GP-MC with Optional Weather Proof Box IP66
	Weight	200g
	Size	140mm X 100mm X 25mm

A DLC5USB [USB] or DLC5 [RS232] download cable is required to connect the GP-MC to a computer.

Product Liability. This information describes our products. It does not constitute guaranteed properties and is not intended to affirm the suitability of a product for a particular application. Due to ongoing research and development, designs, specifications, and documentation are subject to change without notification. Regrettably, omissions and exceptions cannot be completely ruled out. No liability will be accepted for errors, omissions or amendments to this specification. Technical data are always specified by their average values and are based on Standard Calibration Units at 25C, unless otherwise specified. Each product is subject to the 'Conditions of Sale'.

Warning: These products are not designed for use in, and should not be used for patient connected applications. In any critical installation an independent fail-safe back-up system must always be implemented.

GP-MC Applications:

The GP-MC inputs support most industrial signals plus also environmental signals.

Eight Analog Inputs: The GP-MC can log any combination of:

Temperature	Voltage (DC)	
Humidity	Current (DC)	including 4~20mA
Pressure	Leaf Wetness	
Wind Direction	Soil Moisture Tension	
Light	Solar Energy	

Application Connection Diagrams:

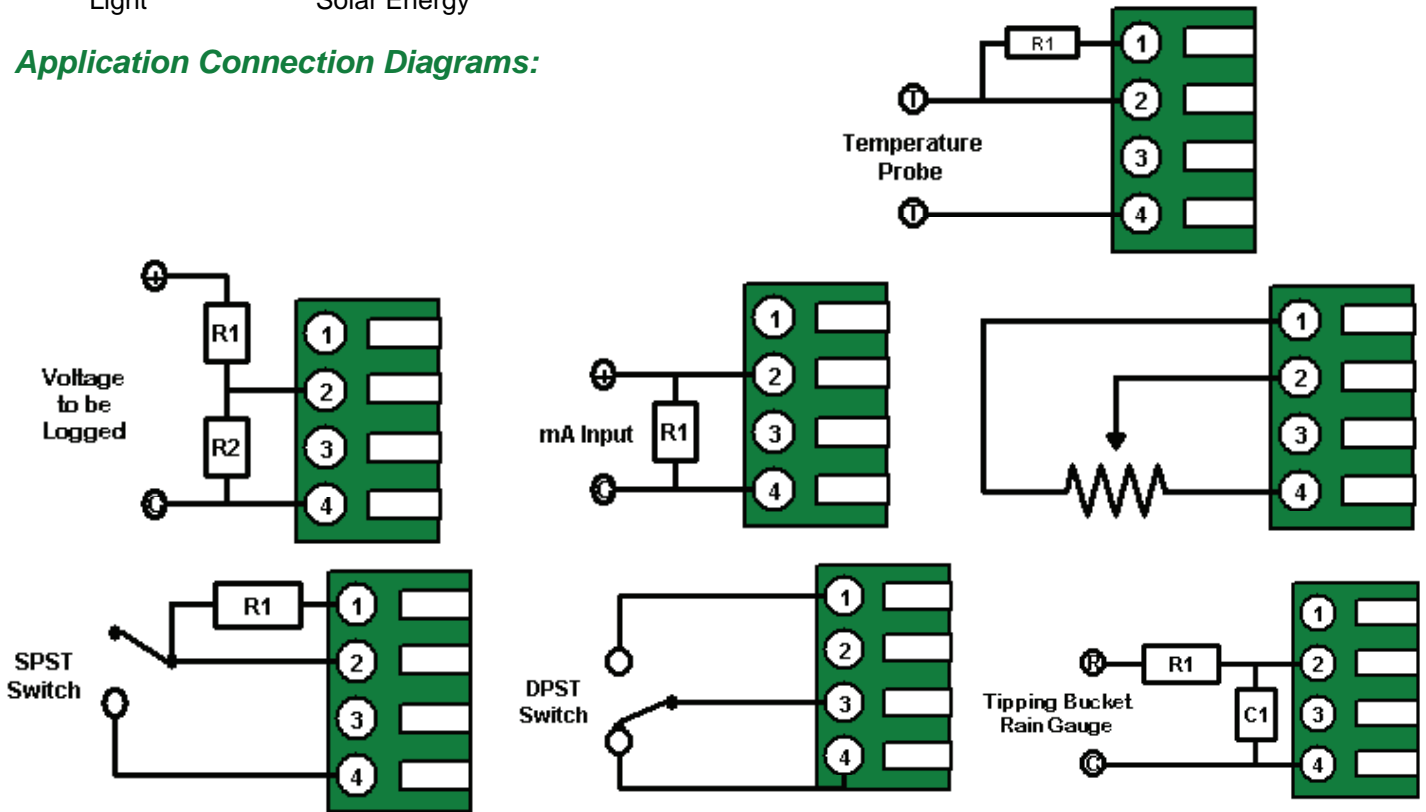

GP-MC Connector Layout:

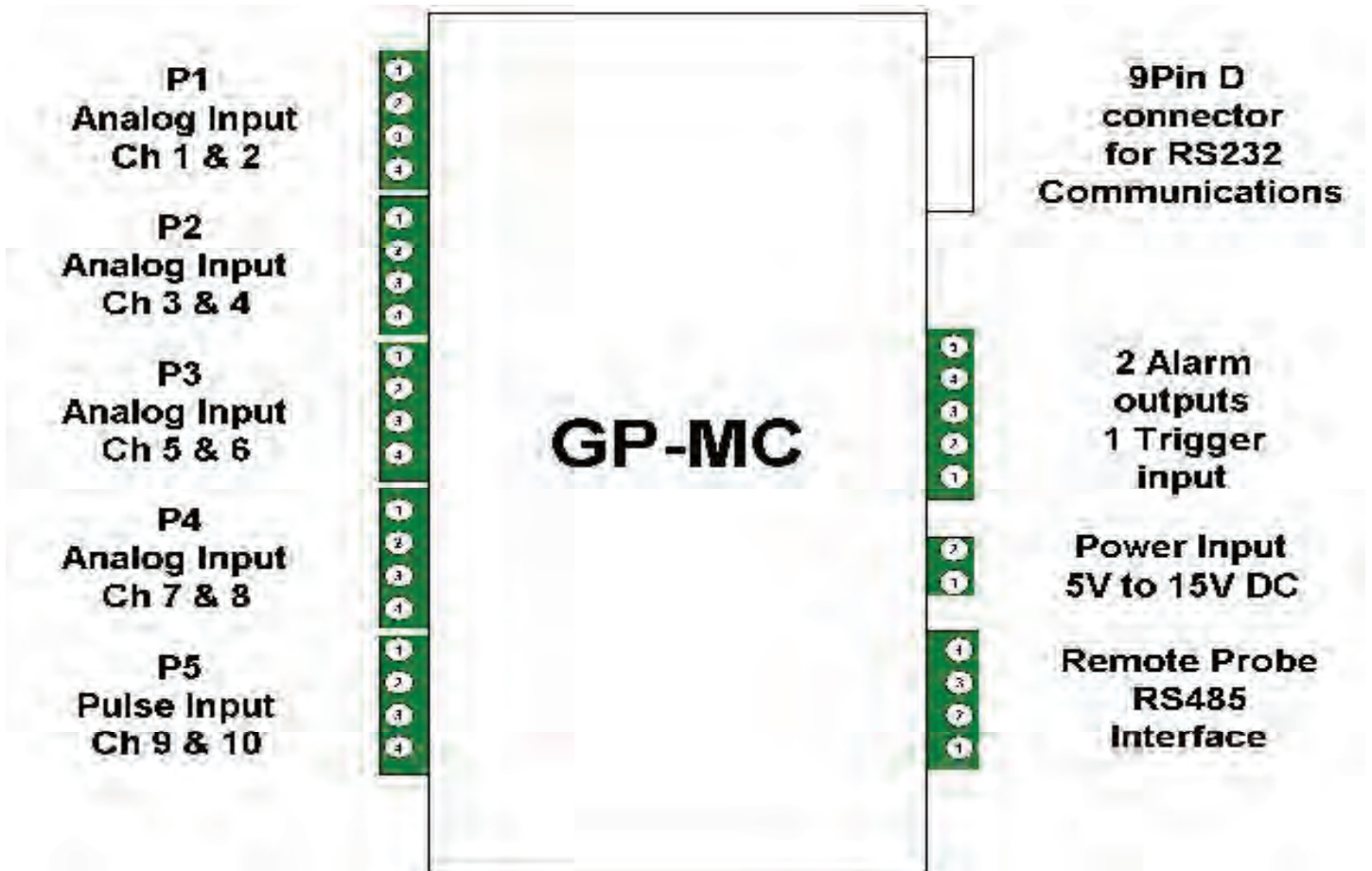

GP-MC - Input Expansion:

RS485 interface to fifteen remote probes or sensors:

The RS485 interface is used to collect additional data from remote probes and sensors. These probes and sensors are connected to Remote Controllers that can communicate with the GP-MC logger over distances of up to 200 meters. A number of these controllers can be daisy chained together on the one RS485 interface. The GP-MC will support up to 15 additional channels from Remote Probe Controllers. At present the following types of RS485 remote data collection devices can be connected to the GP-MC:

1. Remote Probe Controller (RPC)

This device has three analog inputs and one fast pulse input. It is powered from the GP-MC. It has no data storage. When the GP-MC requests data, the RPC converts its inputs and returns its results to the GP-MC via the RS485 interface. The RPC Remote Probe Controller can supply up to 1mA for 30mSec at 3.6 volts to its probes and sensors.

GP-MC RS485 Remote Channels Schematic:

