

# SR90 Series Digital Controller

## COMMUNICATION INTERFACE (RS-232C/RS-485)

### INSTRUCTION MANUAL

Thank you for purchasing the Shimaden SR90 series controller.  
Please check that the delivered product is the correct item you ordered. Please do not begin operating this product until you have read this instruction manual thoroughly and you understand its contents.

This instruction manual describes the communication interface which is an optional function of the SR90 digital controller. For details of SR90's performance and parameters, please refer to the separate instruction manual.

## CONTENTS

1. Outline .....	2
2. Specifications .....	2
3. Connecting controller with host computer .....	2 ~ 3
3-1 RS-232C .....	2
3-2 RS-485 .....	3
3-3 3-state output control .....	3
4. Setting of parameters related to communication .....	3 ~ 5
4-1 Setting of communication mode .....	3
4-2 Setting of communication address .....	4
4-3 Setting of communication data format .....	4
4-4 Setting of start character .....	4
4-5 Communication BCC check setting screen .....	4
4-6 Communication rate setting screen .....	4
4-7 Setting of delay time .....	4
4-8 Communication memory mode selecting screen .....	5
5. Outline of standard serial communication protocols .....	5 ~ 12
5-1 Communication procedure .....	5
5-2 Communication format .....	5
5-3 Details of read commands (R) .....	8
5-4 Details of write commands (W) .....	9
5-5 Details of response codes .....	10
5-6 Details of communication data addresses .....	11
6. Communication data address list .....	12 ~ 15
7. Supplementary explanation .....	15
7-1 Table of measuring range codes .....	15
7-2 Table of event types .....	15
8. ASCII code list .....	16

**SHIMADEN CO., LTD.**

SR90C-1AE  
Dec. 2001

# 1. Outline

There are two types of communication systems, RS-232C and RS-485 employable as the SR90 series communication interface (however, only RS-485 applies for SR91). Each of them is capable of setting various data for the SR90 and reading through a personal computer or the like, using signals which comply with EIA standards. RS-232C and RS-485 are data communication standards established by the Electronic Industries Association of the U.S. (EIA). The standards cover electrical and mechanical aspects, that is, matters related to applicable hardware but not the data transmission procedure of software. Therefore, it is not possible to communicate unconditionally with an apparatus which has the same interface. Hence, users need to have sufficient knowledge of specifications and transmission procedure.

When RS-485 is used, two or more of SR90 controllers can be connected to one another. There seems to be a limited number of personal computers, etc., which support this interface, but the use of a line converter for RS-232C <---> RS-485 creates stability.

# 2. Specifications

- Signal level : Following EIA'S RS-232C and RS-485
- Communication system : RS-232C 3-line half duplex system  
RS-485 2-line half duplex multidrop (bus) system
- Synchronization system : Half duplex start-stop synchronization system
- Communication distance : RS-232C 15 m maximum  
RS-485 maximum total of 500 m (differs depending on conditions.)
- Communication rate : 1200, 2400, 4800, 9600 and 19200bps
- Transmission procedure : No procedure
- Data format : Data 7 bits, even parity stop 1 bit  
Data 8 bits, no parity, stop 1 bit
- Communication code : ASCII codes
- Isolation : Insulated between communication signals and various inputs, system and various outputs

# 3. Connecting controller with host computer

The SR90 series controller is provided with only 3 lines for input and output, i.e., for data transmission, data reception and grounding for signals, not with any other signal lines. Since the controller has no control line, control signals should be taken care of on the host side.

In this instruction, an example of control signal processing methods is shown in drawings (portions surrounded by dotted lines). As the method depends on the system, however, you are advised to refer to the specifications of the host computer for details.

## 3-1. RS-232C

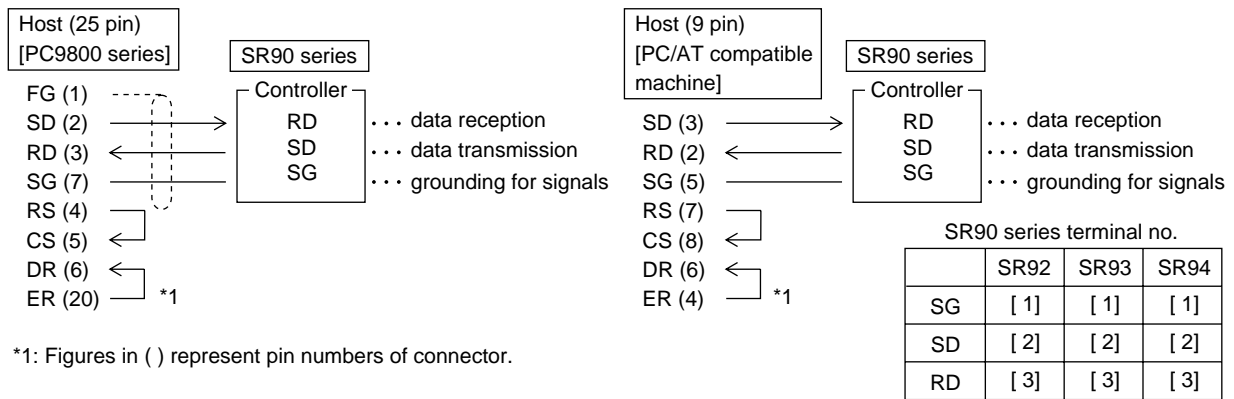

### 3-2. RS-485

The input/output logical level of the SR90 controller is basically as follows:  
 In the mark state - terminal < + terminal  
 In the space state - terminal > + terminal

Until immediately before transmission, however, plus terminals and minus terminals of the controller have high impedance and outputs at the above levels are produced immediately before starting transmission. (See 3-3. 3-state output control.)

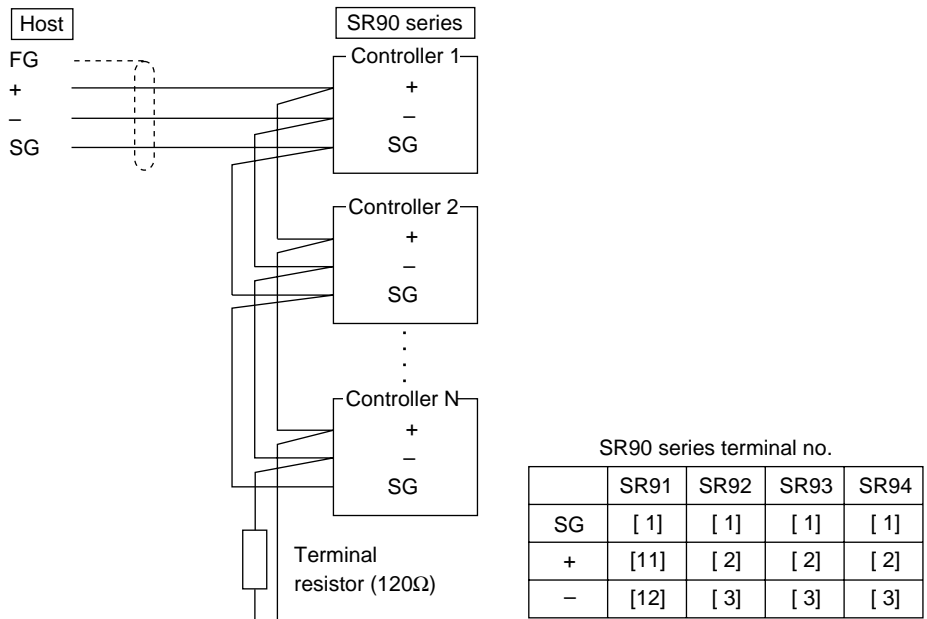

Note 1: In the case of RS-485, provide it with the attached terminal resistor of 1/2W, 120Ω across terminals + and if necessary. Nevertheless, it should be provided to only the last controller. If two or more controllers are provided with terminal resistors, correct operation cannot be guaranteed.

### 3-3. 3-state output control

Since RS-485 is of the multidrop system, transmission output has high impedance always while communication is not carried out or signals are being received in order to avoid collision between transmission signals. It changes from high impedance to the normal output condition immediately before transmission and returns to high impedance control simultaneously when transmission terminates. As the 3-state control is delayed by about 1 msec (maximum) from the completion of transmission of an end character end bit, however, a few microseconds' delay should be provided if the host side starts transmission immediately upon reception.

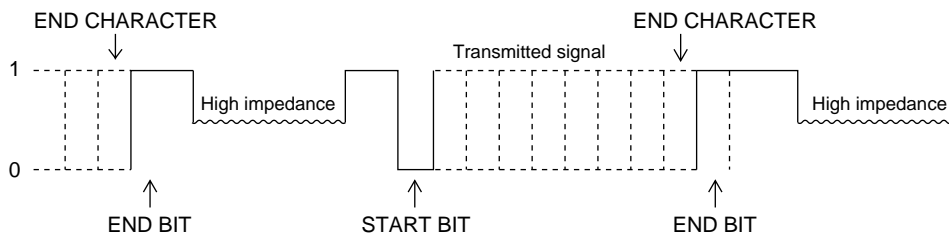

## 4. Setting of parameters related to communication

There are the following 8 communication-related parameters for the SR90 series controller. These parameters are unable to be set or changed by communication; use front key for setting and changing. When parameters are set, see 5. Explanation of Screen and Setting of the separate instruction manual for the controller and follow the described steps.

### 4-1. Setting of communication mode

1-34

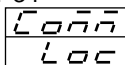

Initial value: Loc  
 Setting range: Com, Loc

Select communication mode. Front key operation allows only change from COM to LOC, though.

Code	Effective command	COM lamp
Loc	Read	Unlighted
Com	Read, write	Lighted

#### 4-2. Setting of communication address

1-35



Initial value: 1  
Setting range: 1 ~ 255

While one SR90 controller is connected to one host computer in the case of 232C, RS-485 employs the multidrop system allowing it to be connected to a maximum of 32. Actually, however, communication has to be carried out bilaterally. Therefore, each instrument is assigned an address (machine No.) so that only the instrument with the designated address can answer.

Note 1: Although 1 to 255 addresses are available for setting, the number of connectable controllers is 31 maximum.

#### 4-3. Setting of communication data format

1-36

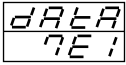

Initial value: 7E1  
Setting range: 2 types shown in the following table.

Select either one of the communication data formats shown below.

Code	Data length	Parity	Stop bit
7E1	7 bit	EVEN	1 bit
8N1	8 bit	None	1 bit

#### 4-4. Setting of start character

1-37

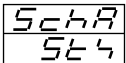

Initial value: STX  
Setting range: STX, ATT

Setting a control code to be used.

Code	Start character	Text end character	End character
STX	STX (02H)	ETX (03H)	CR (0DH)
ATT	"@" (40H)	": " (3AH)	CR (0DH)

#### 4-5. Communication BCC check setting screen

1-38



Initial value: 1  
Setting range: 1 ~ 4

Select a BCC operation method to be used in BCC checking.

Code	BCC operation method
1	Addition
2	Addition +2's complement
3	XOR
4	None

#### 4-6. Communication rate setting screen

1-39

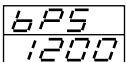

Initial value: 1200 bps  
Setting range: 1200, 2400, 4800, 9600, 19200 bps

Select a rate at which data are transmitted to host computer.

#### 4-7. Setting of delay time

1-40

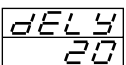

Initial value: 20  
Setting range: 1 ~ 100

Set the length of delay time from receipt of a communication command to transmission.  
Delay time (msec) = Set value (count) × 0.512 (msec)

Note 1: When RS-485 is used, some converters take longer time for 3-state control than others and it may lead to signal collision. This can be avoided by increasing delay time. Care should be taken particularly when the communication rate is slow (1200bps or 2400bps).

Note 2: Actual delay time from receipt of a communication command to transmission is a total of the above-mentioned delay time and command processing time by software. Particularly for writing commands, about 400 msec may be taken for processing.

#### 4-8. Communication memory mode selecting screen

1-41

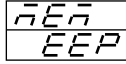

Initial value: EEP  
 Selectable range: EEP, Ram, r\_E

Since the number of writing cycles of volatile memory EEPROM used in SR90 series is fixed, the life of EEPROM is shortened if SV data or the like are rewritten frequently by communication. To prevent this, in case data are to be rewritten frequently by communication, set the RAM mode in which only RAM data are rewritten without rewriting EEPROM, thereby maintaining the life of EEPROM as long as possible.

Code	Description
EEP mode	In this mode EEPROM data are also rewritten every time data are changed by communication. Accordingly, data are maintained when power is turned off.
RAM mode	In this mode only RAM data are rewritten but EEPROM data are not when data are changed by communication. Therefore, RAM data are deleted when power is turned off. Upon applying power again, operation starts with data stored in EEPROM.
r_E mode	SV and OUT data are written in RAM. All other data are written in EEPROM.

### 5. Outline of standard serial communication protocols

In the SR90 series, the Shimaden standard serial communication protocol. This enables you to acquire and/or change data from instruments, which employ the standard serial protocol, by using the same format.

#### 5-1. Communication procedure

- (1) Master/slave relation
  - The master side means personal computer or PLC (host).
  - The slave side means the SR90 series controller.
  - A communication command from the master side starts communication and a response from the slave side terminates it. If abnormality such as a communication format error or a BCC error occurs, there will be no response. No response is sent, either, to broadcast instruction.
- (2) Communication procedure  
 Communication goes on by transferring the transmission right to each other in the pattern that the slave side responds to the master side.
- (3) Time-out  
 In case receipt of the end character does not complete within one second after receiving the start character, it is time-out and the controller is automatically put in the state of waiting for another command (a new start character). Accordingly, the host side should set a one second minimum as the time-out duration.

#### 5-2. Communication format

The SR90 Series allows for a variety of communication formats (start character, text end character, end character and BCC operating method) and communication data formats (data bit length, whether or not of parity, and stop bit length) for easy compliance with other protocols.

Nonetheless, the following serves as their basic format and you are encouraged to use them uniformly:

- Communication format  
 Control code (start character, text end character, end character)→STX\_ETX\_CR  
 Check sum (BCC operating method)→Add
  - Communication data format (data bit length, whether or not of parity, stop bit length)→7E1 or 8N1
- For setting a communication format and a communication data format, see "4. Setting of parameters related to communication."

#### (1) Outline of communication format

The communication format comprises the basic format portion I, the text portion and the basic format portion II.

##### 1) Communication command format

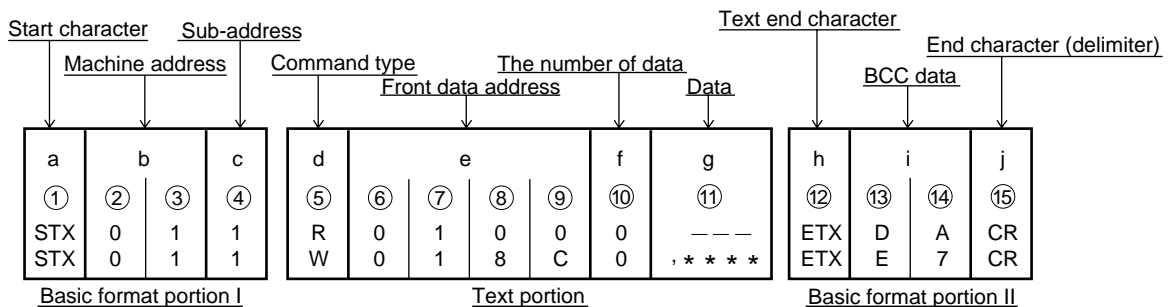

2) Response format

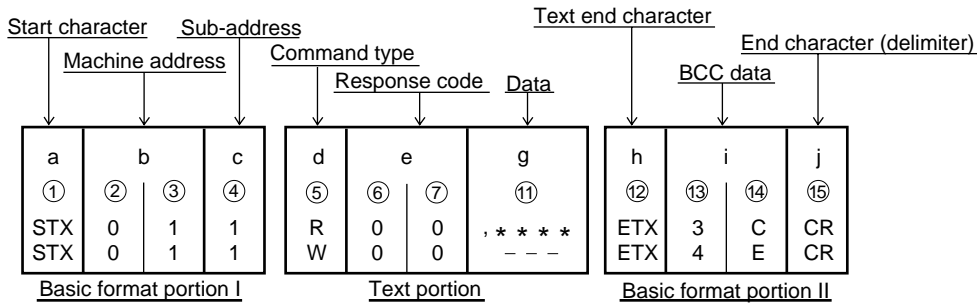

- The basic format portions I and II are common to read commands (R), write commands (W) and responses. Nonetheless, in BCC data of i(⑬, ⑭) operation result data is inserted each time.
- The text portion differs depending on the types of commands, data addresses, responses, etc.

(2) Details of basic format portion I

a : Start character [ ① : 1 digit / STX(02H) or "@"(40H)]

- Indicates the start of communication bloc.
- Upon receipt of start character, it is judged as the first character of a new communication bloc.
- A start character and a text end character are selected in a pair.  
(See 4-4. Setting of start character.)  
Select with STX (02H) ---- ETX (03H), or select with "@"(40H) ---- ":"(3AH).

b : Machine address [ ②, ③ : 2 digits]

- Designates the instrument to communicate with.
- Address can be designated in a range from 1 to 255 (10 numerals).
- Binary 8 bit data (1 : 0000 0001 ~ 99 : 0110 0011) are split into high position 4 bits and low position 4 bits and converted to ASCII data.  
②: ASCII data converted from the high position 4 bits.  
③: ASCII data converted from the low position 4 bits.
- Since the machine address=0 (30H, 30H) is used for broadcast instruction, it cannot be used as a machine address. As the SR90 series controller does not support broadcast instruction, address=0 has no response.

c : Sub-address [ ④ : 1 digit]

- As the SR90 series are single loop controllers, their sub-address is fixed to ④ = 1 (31H).  
Designation of any other address is taken as a sub-address error and there

will be no response.

(3) Details of basic format portion II

h : Text end character [ ⑫ : 1 digit / ETX(03H) or ":" (3AH) ]

- Indicates that the text portion terminates right before this character.

i : BCC data [ ⑬, ⑭ : 2 digits]

- BCC (Block Check Character) checks if there is any error in communication.
- There will be no response if BCC operation results in a BCC error.
- The following indicates the 4 types of BCC operation: (Type of BCC operation can be set on the front screen.)  
(1) Add  
Add operation is performed on every 1 character of ASCII data (1 byte) from the start character ① through the text end character ⑫.  
(2) Add + 2' complement  
Add operation is performed on every 1 character of ASCII data (1 byte) from the start character ① through the text end character ⑫, and two's complement of the low position 1 byte of the operation result is taken.  
(3) Exclusive OR  
XOR (exclusive OR) operation is performed on every 1 character of ASCII data (1 byte) from the machine address ② right after the start character through the text end character ⑫.  
(4) None  
BCC operation is not performed. (⑬, ⑭ are omitted.)
- Regardless of the length of data bits (7 or 8), operation is carried out with 1 byte (8 bits) as a unit.
- The low position 1 byte data obtained as a result of the operations mentioned above is split into high position 4 bits and low position 4 bits and converted to ASCII codes.  
⑬: ASCII data converted from high position 4 bits.  
⑭: ASCII data converted from low position 4 bits.

Example 1: In the case of a read command (R) with Add set for BCC

①	②	③	④	⑤	⑥	⑦	⑧	⑨	⑩	⑫	⑬	⑭	⑮
STX	0	1	1	R	0	1	0	0	0	ETX	D	A	CR
02H	+30H	+31H	+31H	+52H	+30H	+31H	+30H	+30H	+30H	+30H	+03H	= 1DAH	

Low position 1 byte of result of addition (1DAH)=DAH

⑬: "D"=44H, ⑭: "A" = 41H

Example 2: In the case of a read command (R) with Add + 2's complement set for BCC

①	②	③	④	⑤	⑥	⑦	⑧	⑨	⑩	⑫	⑬	⑭	⑮
STX	0	1	1	R	0	1	0	0	0	ETX	2	6	CR

02H +30H +31H +31H +52H +30H +31H +30H +30H +30H +03H = 1DAH

Low position 1 byte of result of addition (1DAH)=DAH  
 Two's complement of low position 1 byte (DAH)=26H  
 ⑬: "2"=32H, ⑭: "6"=36H

Example 3: In the case of a read command (R) with XOR set for BCC

①	②	③	④	⑤	⑥	⑦	⑧	⑨	⑩	⑫	⑬	⑭	⑮
STX	0	1	1	R	0	1	0	0	0	ETX	5	0	CR

02H 30H ⊕31H ⊕31H ⊕52H ⊕30H ⊕31H ⊕30H ⊕30H ⊕30H ⊕03H = 50H

• ⊕ = XOR (exclusive OR), though.

Low position 1 byte of result of operation (50H)=50H  
 ⑬: "5"=35H, ⑭: "0"=30H

j : End character (delimiter) [ ⑮ : 1 digit/CR ]  
 • Indicates that it is the end of communication message.

(4) Basic format portions I and II common condition

- If abnormalities as listed below are found in the basic format portions, there will be no response:
  - There is a hardware error.
  - Machine address or sub-address is different from that of the designated instrument.
  - Any of the characters specified in the above communication format is not in its specified position.
  - The result of BCC operation differs from BCC data.
- Conversion of data: Every 4 bits of binary data are converted to ASCII data.
- <A> through <F> in hexadecimal numbers are converted to ASCII data by using capital letters.

(5) Outline of text portion

The text portion changes according to the types of commands and responses. For details of the text portion, see 5-3 Details of read commands (R) and 5-4. Details of write commands (W).

d : Type of commands [ ⑤ : 1 digit ]

- "R" (52H/capital letter): Indicates that it is a read command or a response to read command. Used to read (take) various data of SR90 from personal computer, PLC, etc.
- "W" (57H/capital letter): Indicates that it is a write command or a response to write command. Used to write (change) various data in SR90 from personal computer, PLC, etc.
- "B" (42H/capital letter): Indicates that it is broadcast instruction. Since SR90 does not support broadcast instruction, this is unable to be used.
- There is no response when any other abnormal character besides "R" and "W" is recognized.

e : Front data address [ ⑥, ⑦, ⑧, ⑨ : 4 digits ]

- For a read command (R) or a write command (W), designates a front data address of where to read from or write in.
- A front data address is designated by binary number 16 bit (1 word/0 ~ 65535) data.
- 16 bit data are split into 4 bit groups and converted to ASCII data.

Binary numbers (16 bits)	D15, D14, D13, D12 0 0 0 0	D11, D10, D9, D8 0 0 0 1	D7, D6, D5, D4 1 0 0 0	D3, D2, D1, D0 1 1 0 0
Hexadecimal numbers (Hex)	0H " 0 "	1H " 1 "	8H " 8 "	CH " C "
ASCII data	30H ⑥	31H ⑦	38H ⑧	43H ⑨

- For data addresses, refer to 6. Details of communication data addresses.

f : The number of data [ ⑩ : 1 digit ]

- For a read command (R) or a write command (W), designates the number of data to be read or written.
- The number of data is designated in the following range by converting binary number 4 bit data to ASCII data:  
 "0" (30H) (one) ~ "9" (39H) (ten)
- For write commands, the number is fixed to "0" (30H) (one).
- The actual number of data is <the number of data = designated numerical value of data + 1>.

g : Data [ ⑪ : The number of digits depends on the number of data.]

- Designates data to be written (data to be changed) for write command (W) or data to be read for response to a read command (R).
- The data format is as follows:

g ( ⑪ )

" "	First data				Second data				nth data			
	High position 1st digit	2nd digit	3rd digit	Low position 4th digit	High position 1st digit	2nd digit	3rd digit	Low position 4th digit	High position 1st digit	2nd digit	3rd digit	Low position 4th digit

- Data is always preceded by comma (", " 2CH) to show the subsequent portion is data.
  - No punctuation code is used between data and data.
  - The number of data is determined by the number of data (f: ⑩) of the communication command format.
  - Each data is expressed by binary 16 bits (1 word), excluding a decimal point, as a unit. The position of decimal point is fixed in each data.
  - 16 bit data are split into 4 bit groups and respectively converted to ASCII data.
  - For details of data, refer to 5-3. Details of read commands (R) and 5-4. Details of write command (W).
- e : Response code [⑥, ⑦: 2 digits]
- Designates a response code to a read command (R) or a write command (W).
  - Binary 8 bit data (0 ~ 255) are split to high position 4 bits and low position 4 bits and respectively converted to ASCII data.
    - ⑥: ASCII data converted from high position 4 bits.
    - ⑦: ASCII data converted from low position 4 bits.
  - In the case of normal response, "0" (30H), "0" (30H) is designated.
  - In the case of abnormal response, abnormal code No. is converted to ASCII data and designated.
  - For details of response codes, refer to 5-5. Details of Response codes.

### 5-3. Details of read commands (R)

Read commands (R) are used by a personal computer, PLC or the like to read (take) various data in SR90.

#### (1) Read Command (R) format

- The format of the text portion of a read command (R) is shown below:  
(The basic format portions I and II are common to all commands and responses.)

Text portion

d	e					f
⑤	⑥	⑦	⑧	⑨	⑩	
R	0	4	0	0	4	
52H	30H	34H	30H	30H	34H	

- d: Indicates that it is a read command.
- e: Designates the front data address of data to be read.
- f: Designates how many data (words) are to be read from the front data address.

- The above command means the following:
    - Front data address of data to be read = 0400H (hexadecimal)  
= 0000 0100 0000 0000 (binary)
    - The number of data to be read = 4H (hexadecimal)  
= 0100 (binary)  
= 4 (decimal)
    - (The actual number of data) = 5 (4 + 1)
- Thus, the command designates reading of 5 data from the data address 0400H.

#### (2) Normal response format to read command (R)

- The following is the normal response format (text portion) to read commands (R):  
(The basic format portions I and II are common to all commands and responses.)

Text portion

d	e		g												
⑤	⑥	⑦	⑩												
R	0	0	first data      second data      5th data												
52H	30H	30H	2CH	30H	30H	31H	45H	30H	30H	37H	38H	30H	30H	30H	33H

- d(⑤): <R (52H)> indicating that it is a response to a read command (R) is inserted.
- e(⑥, ⑦): The response code <0 0 (30H, 30H)> indicating that it is a normal response to the read command (R) is inserted.
- g(⑩): Response data to the read command is inserted.  
The data format is as follows:
  1. To begin with, <, (2CH)> indicating the head of data is inserted.
  2. Then, data in the number according to <the number of data to be read> are inserted one by one, starting from the <data of the front data address for reading>.
  3. Nothing is inserted between the respective data.
  4. The respective data comprise binary 16 bits (1 word) data, excluding a decimal point, and are converted, 4 bits as a unit, to ASCII data and inserted.
  5. The position of decimal point is fixed in the respective data.
  6. The number of characters of response data is as follows:  
Number of characters = 1 + 4 × number of data to be read

	Data address 16 bits (1 word)		Data 16 bits (1 word)	
	Hexadecimal		Hexadecimal	decimal
Read head data address (0400H) →	0	0400	001E	30
	1	0401	0078	120
The number of data to be read (4H: 5)	2	0402	001E	30
	3	0403	0000	0
	4	0404	0003	3

- To the above read command (R), the following data are returned one by one as response data: Thus, the above data can be read.

(3) Abnormal response format to read command (R)

- The following is the abnormal response format (text portion) to read commands (R): (The basic format portions I and II are common to all commands and responses.)

Text Portion

d	e	
⑤	⑥	⑦
R	0	7
52H	30H	37H

- d(⑤): <R (52H)> indicating that it is a response to a read command (R) is inserted.
- e(⑥, ⑦): A response code indicating that it is an abnormal response to the read command (R) is inserted.
- For details of abnormal response code, refer to 5-5. Details of response codes.
- No response data are inserted in an abnormal response.

#### 5-4. Details of write commands (W)

A write command is used by a personal computer, PLC, etc. to write (change) various data in SR90.

To use a write command, the COM mode has to be selected on the 4-1 Communication mode selecting screen. As this parameter is unable to be changed from LOC to COM by front key operation, however, the change should be made by the following command transmission: (In the case of address=01, sub-address=1, start character=STX and BBC operation=addition)

Command format

STX	0	1	1	W	0	1	8	C	0	,	0	0	0	1	ETX	E	7	CR
02H	30H	31H	31H	57H	30H	31H	38H	43H	30H	2CH	30H	30H	30H	31H	03H	45H	37H	0DH

Once the above command is transmitted and a normal response is returned, the COM LED lamp on the front panel lights and mode is changed to communication.

(1) Write command (W) format

- The following is the text format of a write command. (The basic format portions I and II are common to all commands and responses.)

Text Portion

d	e					f	g			
⑤	⑥	⑦	⑧	⑨	⑩	⑪				
W	0	4	0	0	0	,	0	0	2	8
57H	30H	34H	30H	30H	30H	2CH	30H	30H	32H	38H

Data to be written

- d: Indicates that it is a write command. It is fixed to "W" (57H).
- e: Designates the front data address of data to be written (changed).
- f: Designates the number of data to be written (changed).
- g: Designates data to be written (changed).
  - To begin with, <(2CH)> indicating the head of data is inserted.
  - Then, data to be written (changed) are inserted.
  - The respective data comprise binary 16 bits (1 word) data, excluding a decimal point, and are converted, 4 bits as a unit, to ASCII data and inserted.
  - The position of decimal point is fixed in the respective data.
- The above command means the following:

Front data address of data to be written = 0400H (hexadecimal)  
 = 0000 0100 0000 0000 (binary)  
 The number of data to be written = 0H (hexadecimal)  
 = 0000 (binary)  
 = 0 (decimal)  
 (The actual number of data) = one (0+1)  
 Data to be written = 0028H (hexadecimal)  
 = 0000 0000 0010 1000 (binary)  
 = 40 (decimal)

Thus, writing (changing) of data address 0400H and one piece of data (40: decimal) is designated.

		Data address 16 bits (1 word)		Data 16 bits (1 word)	
		Hexadecimal	Decimal	Hexadecimal	Decimal
Address (400H) → 0 The number of data to be written: one (0H)		0400	1024	0028	40
		0401	1025	0078	120
		0402	1026	001E	30

(2) Normal response format to write command (W)

- The following is the normal response format (text portion) to a write command (W).  
 (The basic format portions I and II are common to all commands and responses.)

text portion

d ⑤	e ⑥   ⑦	
W 57H	0 30H	0 30H

- d(⑤): <W (57H)> indicating that it is a response to a write command (W) is inserted.
- e(⑥, ⑦): A response code <00 (30H, 30H)> indicating that it is a normal response to the write command (W) is inserted.

(3) Abnormal response format to write command (W)

- The following is the abnormal response format (text portion) to a write command (W).  
 (The basic format portions I and II are common to all commands and responses.)

text portion

d ⑤	e ⑥   ⑦	
W 57H	0 30H	9 39H

- d(⑤): <W (57H)> indicating that it is a response to a write command (W) is inserted.
- e(⑥, ⑦): A response code indicating that it is an abnormal response to the write command (W) is inserted.
- For details of abnormal codes, refer to 5-5 Details of response codes.

## 5-5. Details of response codes

(1) Types of response codes

- Communication responses to read commands (R) and write commands (W) always contains response codes.
- Response codes are divided broadly into two types:

Response codes { Normal response codes  
 Abnormal response codes

- A response code comprises 8 bits data of binary numbers (0 ~ 255).
- The types of response codes are listed below:

### A List of Response Codes

Response code		Type of code	Description
Binary numbers	ASCII		
0000 0000	"0", "0" : 30H, 30H	Normal response	Normal response to read command (R) or write command (W)
0000 0001	"0", "1" : 30H, 31H	Hardware error in text portion	When a hardware error such as framing overrun or parity error has been detected in data in the text portion.
0000 0111	"0", "7" : 30H, 37H	Format error of text portion	Format of text portion is different from what was fixed.
0000 1000	"0", "8" : 30H, 38H	Error in data of text portion, data address or the number of data	Data of text portion is not in fixed format, or data address or the number of data is different from designated one.
0000 1001	"0", "9" : 30H, 39H	Data error	Data to be written get beyond range in which setting is possible.
0000 1010	"0", "A" : 30H, 41H	Execution command error	Execution command (such as AT command) was received in conditions where that execution command is not acceptable.
0000 1011	"0", "B" : 30H, 42H	Write mode error	Some types of data are unable to be changed at certain points in time. Write command containing such data was received at such a time.
0000 1100	"0", "C" : 30H, 43H	Specification or option error	Write command containing data of specification or option which was not added was received.

(2) Priority order of response codes

The smaller the value of response code, the higher the priority of the response code; When two or more response codes are generated, a response code of higher priority order is returned.

#### 5-6. Details of communication data addresses

(1) Data address and read/write

- In a data address, binary numbers (16 bit data) are expressed by hexadecimal numbers, with 4 bits as a unit.
- R/W means that data are capable of being read and written.
- R means that data are only for reading.
- W means that data are only for writing.
- In case a data address only for writing is designated by a read command (R), or a data address only for reading is designated by a write command (W), it results in a data address error and the abnormal response code "0", "8" (30H, 38H) "error in data format, data address or the number of data in text portion" is returned.

(2) Data address and the number of data

- If a data address which is not included in the data addresses for SR90 is designated as the front data address, it results in a data address error, and the abnormal response code "0", "8" (30H, 38H) "error in data format, data address or the number of data in text portion" is returned.
- Even when a front data address is included in the data address list, the data address added with the number of data gets out of the data address list, it results in an error of the number of data, and abnormal response code "0", "8" (30H, 38H) " is returned.

(3) Data

- Since data comprise binary numbers (16 bit data) without a decimal point, the form of data, whether there is a decimal point or not, etc., have to be confirmed. (See the instruction manual of the instrument itself.)

Example: How to express data with decimal point

			Hexadecimal data
20.0%	→	200	→ 00C8
100.00°C	→	10000	→ 2710
-40.00°C	→	-4000	→ F060

- In data of which the unit is UNIT, the position of decimal point depends on the measuring range.
- In case of a special measuring range, (measuring range of over 0 ~ 50,000°C such as 32768) binary numbers without code (16 bit data: 0 ~ 65535) will be used for the data which depends on the measuring range.
- In other data than the above, binary numbers with code (16 bit data: -32768 ~ 32767) are used.

Example) How to express 16 bit data

Data with code		Data without code	
Decimal	Hexadecimal	Decimal	Hexadecimal
0	0000	0	0000
1	0001	1	0001
⋮	⋮	⋮	⋮
32767	7FFF	32767	7FFF
-32768	8000	32768	8000
-32767	8001	32769	8001
⋮	⋮	⋮	⋮
-2	FFFE	65534	FFFE
-1	FFFF	65535	FFFF

(4) <Reserved> in parameter portions

- When a <reserved> portion is read in reply to a read command (R), or written in reply to a write command (W), normal response code "0", "0" (30H, 30H) is returned.

(5) Option-related parameters

- When the data address of a parameter which is not added as an option is designated, abnormal response code "0", "C" (30H, 43H)"Specification, option error" is returned to a read command (R) as well as a write command (W). If an address of data only for reading is read, however, the (0000H) data are returned.

(6) Parameters not shown in front panel displays owing to action specifications or setting specifications

- Even parameters which are not shown (used) on the front panel displays owing to action specifications or setting specifications are possible to be read and written in communication.

## 6. Communication data address list

Data address (hex)	Parameter	Setting range	R/W	
0040		Series code 1	Unless four series codes from 0x0040 are read at a time, an error code (08) will be returned.	R
0041		Series code 2		R
0042		Series code 3		R
0043		Series code 4		R

- The address areas listed above become product ID data areas and data are ASCII data, 8 bits as a unit. Therefore, one address represents two data.
- A series code is expressed by 8 data maximum and a surplus area is filled with 00H data.

Example 1) SR91	Address	H	L	H	L	Example 2) SR92	Address	H	L	H	L
	0040	"S"	"R"	53H	52H		0040	"S"	"R"	53H	52H
	0041	"9"	"1"	39H	31H		0041	"9"	"2"	39H	32H
	0042			00H	00H		0042			00H	00H
	0043			00H	00H		0043			00H	00H

- Code selection data are expressed by 56 data maximum and a surplus area is filled with 00H data.

Data address (hex)	Parameter	Setting range	R/W
0100	PV_W	Measured value	R
0101	SV_W	SV value in execution	R
0102	OUT1_W	Control output 1 value	R
0103	OUT2_W	Control output 2 value (without option = 0000H)	R
0104	EXE_FLG	Action flag (bit without action = 0)	R
0105	EV_FLG	Event output flag (without option = 0000H)	R

0109	HB_W	HB current value (without option = 0000H)	R
010A	HL_W	HL current value (without option =0000H)	R

- EXE\_FLG, EV\_FLG Details are shown below.

	D15	D14	D13	D12	D11	D10	D9	D8	D7	D6	D5	D4	D3	D2	D1	D0
EXE_FLG :	0	0	0	0	0	0	0	COM	0	0	0	0	0	0	MAN	AT
EV_FLG :	0	0	0	0	0	0	0	0	0	0	0	0	0	0	EV2	EV1

- Higher limit side PV\_SO, CJ\_SO, b ---, REM\_SO, HB\_SO = 7FFFH
- Lower limit side PV\_SO, CJ\_SO, c ---, REM\_SO, HB\_SO = 8000H
- Invalid data for HB and HL=7FFEh

Data address (hex)	Parameter	Setting range	R/W
0182	OUT1_W	Control output 1, Set value in MAN operation	W
0183	OUT2_W	Control output2, Set value in MAN operation	W
0184	AT	0=No execution, 1=Execution	W
0185	MAN	0=AUTO, 1=MAN	W

018C	COM	0=LOC, 1=COM	W
------	-----	--------------	---

0300	SV1	Target set value	R/W
------	-----	------------------	-----

030A	SV_L	Set value limiter on lower limit side	R/W
030B	SV_H	Set value limiter on higher limit side	R/W

0400	PB1	control output 1 proportional band	R/W
0401	IT1	control output1 integral time	R/W
0402	DT1	control output1 derivative time	R/W
0403	MR1	manual reset	R/W
0404	DF1	Hysteresis	R/W
0405	011_L	control output 1 lower output limiter	R/W
0406	011_H	control output 1 higher output limiter	R/W
0407	SF1	control output 1 target value function	R/W

0460	PB21	control output 2 proportional band	(option)	R/W
0461	IT21	control output 2 integral time	(option)	R/W
0462	DT21	control output 2 derivative time	(option)	R/W
0463	DB21	dead band	(option)	R/W
0464	DF21	Hysteresis	(option)	R/W
0465	021_L	control output 2 lower output limiter	(option)	R/W
0466	021_H	control output 2 higher output limiter	(option)	R/W
0467	SF21	control output 2 target value function	(option)	R/W

Data address (hex)	Parameter	Setting range	R/W
0500	EV1_MD	Event 1 mode See "7-2 Event type list." (option)	R/W
0501	EV1_SP	Event 1 set value See "7-2 Event type list." (option) A change to communication is also possible when <i>OFF</i> , <i>So</i> or <i>Hb</i> is set for the event mode but any change of event mode is followed by initialization. (Writable range = -1999 ~ 9999)	R/W
0502	EV1_DF	Event 1 hysteresis (option)	R/W
0503	EV1_STB	Event 1 stand-by actions (option) 1: Alarm action without stand-by 2: Alarm action with stand-by (when power is plied) 3: Alarm action with stand-by (when power is applied and when SV is changed) 4: Control action without stand-by	R/W
0508	EV2_MD	Event 2 mode See "7-2 Event type list." (option)	R/W
0509	EV2_SP	Event 2 set value See "7-2 Event type list." (option) A change to communication is also possible when <i>OFF</i> , <i>So</i> or <i>Hb</i> is set for the event mode but any change of event mode is followed by initialization. (Writable range = -1999 ~ 9999)	R/W
050A	EV2_DF	Event 2 hysteresis (option)	R/W
050B	EV2_STB	Event 2 standby actions (option) 1: Alarm action without standby 2: Alarm action with standby (when power is plied) 3: Alarm action with standby (when power is applied and when SV is changed) 4: Control action without standby	R/W
0590	HBS	Heater break alarm setting (option)	R/W
0591	HBL	Heater loop alarm setting (option)	R/W
0592	HB_MD	Setting of heater break alarm mode 0=LC, 1=RE (option)	R/W
0593	Reserved	Heater loop alarm setting (option)	R/W
0594	HB_STB	Heater break standby setting 0=OFF, 1=ON (option)	R/W
05A0	A01_MD	Analog output mode 0=PV, 1=SV, 2=dEV, 3=OUT1, 4=OUT2 (option)	R/W
05A1	A01_L	Analog output scale on lower limit side (option)	R/W
05A2	A01_H	Analog output scale on higher limit side (option)	R/W
05B0	COM_MEM	Communication memory mode 0=EED, 1=RAM, 2=r_E (option)	R/W
0600	ACTMD	Output characteristics 0=rA, 1=dA	R/W
0601	01_CYC	SV1 proportional cycle	R/W
0604	02_CYC	SV2 proportional cycle (option)	R/W
060A	SOFTD1	Set data for soft start 1	R/W
0611	KLOCK	Keylock 0=OFF 1=Lock except the screen group for user's setting and communication mode 2=Lock except SV and communication mode 3=Lock except communication mode	R/W
0701	PV_B	PV bias	R/W
0702	PV_F	PV filter	R/W

Data address (hex)	Parameter	Setting range	R/W
0704	UNIT	Unit of input data 0: "°C" 1: "°F"	R/W
0705	RANGE	Refer to 7-1. Table of measuring range codes	R/W
0706	Reserved		R/W
0707	DP	0: None 1: 0.1 2: 0.01 3: 0.001	R/W
0708	SC_L	-1999 ~ 9989 UNIT	R/W
0709	SC_H	-1989 ~ 9999 UNIT	R/W

## 7. Supplementary explanation

### 7-1. Table of measuring range codes

Input	Code	Type of Input	Measuring range	
			°C	°F
Multi-input	Thermocouple	01 B *1	0 ~ 1800	0 ~ 3300
		02 R	0 ~ 1700	0 ~ 3100
		03 S	0 ~ 1700	0 ~ 3100
		04 K	-199.9 ~ 400.0	-300 ~ 750
		05 K	0.0 ~ 800.0	0 ~ 1500
		06 K	0 ~ 1200	0 ~ 2200
		07 E	0 ~ 700	0 ~ 1300
		08 J	0 ~ 600	0 ~ 1100
		09 T	-199.9 ~ 200.0	-300 ~ 400
		10 N	0 ~ 1300	0 ~ 2300
		11 PLII	0 ~ 1300	0 ~ 2300
		12 WRe5-26	0 ~ 2300	0 ~ 4200
		13 U	-199.9 ~ 200.0	-300 ~ 400
		14 L	0 ~ 600	0 ~ 1100
Multi-input	R.T.D.	31 Pt100	-200 ~ 600	-300 ~ 1100
		32 Pt100	-100.0 ~ 100.0	-150.0 ~ 200.0
		33 Pt100	-50.0 ~ 50.0	-50.0 ~ 120.0
		34 Pt100	0.0 ~ 200.0	0.0 ~ 400.0
		35 Jpt100	-200 ~ 500	-300 ~ 1000
		36 Jpt100	-100.0 ~ 100.0	-150.0 ~ 200.0
		37 Jpt100	-50.0 ~ 50.0	-50.0 ~ 120.0
38 Jpt100	0.0 ~ 200.0	0.0 ~ 400.0		
Multi-input	mV	71 -10 ~ 10mV	Owing to scaling function, any measuring range can be set within the following range.  Scaling range: -1999 to 9999 counts Span : 10 to 5000 counts on condition of lower side < higher side, though.	
		72 0 ~ 10mV		
		73 0 ~ 20mV		
		74 0 ~ 50mV		
		75 10 ~ 50mV		
		76 0 ~ 100mV		
Voltage	V	81 -1 ~ 1V		
		82 0 ~ 1V		
		83 0 ~ 2V		
		84 0 ~ 5V		
		85 1 ~ 5V		
		86 0 ~ 10V		
Current	mA	91 0 ~ 20mA		
		92 4 ~ 20mA		

\*1 Thermocouple B: Accuracy cannot be guaranteed on temperatures below 400 °C and 752 °F.

### 7-2. Table of event types

Alarm code	Event type	Number	Initial value	Setting range
<i>oFF</i>	None	0	-----	-----
<i>Hd</i>	Higher limit deviation	1	2000 Unit	-1999 ~ 2000 Unit
<i>Ld</i>	Lower limit deviation	2	-1999 Unit	-1999 ~ 2000 Unit
<i>od</i>	Outside higher/lower limit deviations	3	2000 Unit	0 ~ 2000 Unit
<i>ld</i>	Within higher/lower limit deviations	4	2000 Unit	0 ~ 2000 Unit
<i>HA</i>	Higher limit absolute value	5	Higher limit vale of measuring range	Within measuring range
<i>LA</i>	Lower limit absolute value	6	Lower limit value of measuring range	Within measuring range
<i>So</i>	Scaleover	7	EV output to continue after scaleover	
<i>Hb</i>	Heater break/heater loop	8	EV output to continue after heater break alarm is output.	

## 8. ASCII code list

	b7b6b5	000	001	010	011	100	101	110	111
b4 ~ b1		0	1	2	3	4	5	6	7
0000	0	NUL	TC7 (DLE)	SP	0	@	P	`	p
0001	1	TC1 (SOH)	DC1	!	1	A	Q	a	q
0010	2	TC2 (STX)	DC2	”	2	B	R	b	r
0011	3	TC3 (ETX)	DC3	#	3	C	S	c	s
0100	4	TC4 (EOT)	DC4	\$	4	D	T	d	t
0101	5	TC5 (ENQ)	TC8 (NAK)	%	5	E	U	e	u
0110	6	TC6 (ACK)	TC9 (SYN)	&	6	F	V	f	v
0111	7	BEL	TC10 (ETB)	'	7	G	W	g	w
1000	8	FE0 (BS)	CAN	(	8	H	X	h	x
1001	9	FE1 (HT)	EM	)	9	I	Y	i	y
1010	A	FE2 (LF)	SUB	*	:	J	Z	j	z
1011	B	FE3 (VT)	ESC	+	;	K	[	k	{
1100	C	FE4 (FF)	IS4 (FS)	,	<	L	\	l	
1101	D	FE5 (CR)	IS3 (GS)	-	=	M	]	m	}
1110	E	SO	IS2 (RS)	.	>	N	^	n	~
1111	F	SI	IS1 (US)	/	?	O	_	o	DEL

Distributed in New Zealand by:

***Intech*** INSTRUMENTS LTD

Christchurch Auckland [www.intech.co.nz](http://www.intech.co.nz)  
 Ph: +6433430646 098271930 [sales@intech.co.nz](mailto:sales@intech.co.nz)  
 Fx: +6433430649 098271931

The contents of this instruction manual are subject to change without notice for improvement.

Temperature and Humidity Control Specialists

**SHIMADEN CO., LTD.**

Head Office: 2-30-10 Kitamachi, Nerima-Ku, Tokyo 179-0081 Japan  
 Phone: +81-3-3931-7891 Fax: +81-3-3931-3089  
 E-MAIL: exp-dept@shimaden.co.jp URL: <http://www.shimaden.co.jp>

PRINTED IN JAPAN