

# SR80 Series Digital Controller

## COMMUNICATION INTERFACE (RS-232C/RS-485)

### INSTRUCTION MANUAL

Thank you for purchasing the Shimaden SR80 series controller.  
Please check that the delivered product is the correct item you ordered. Please do not begin operating this product until you have read this instruction manual thoroughly and you understand its contents.

This instruction manual describes the communication interface which is an optional function of the SR80 digital controller. For details of SR80's performance and parameters, please refer to the separate instruction manual.

## CONTENTS

1. Outline .....	2
2. Specifications .....	2
3. Connecting controller with host computer .....	2 ~ 3
3-1 RS-232C .....	2
3-2 RS-485 .....	3
3-3 3-state output control .....	3
4. Setting of parameters related to communication .....	3 ~ 5
4-1 Communication mode selecting screen .....	3
4-2 Communication address setting screen .....	4
4-3 Communication rate setting screen .....	4
4-4 Communication data format setting screen .....	4
4-5 Communication control code setting screen .....	4
4-6 Communication BCC check setting screen .....	4
4-7 Communication memory mode selecting screen .....	4
4-8 Communication delay time setting screen .....	4
5. Outline of standard serial communication protocols .....	5 ~ 12
5-1 Communication procedure .....	5
5-2 Communication format .....	5
5-3 Details of read commands (R) .....	8
5-4 Details of write commands (W) .....	9
5-5 Details of response codes .....	10
5-6 Details of communication data addresses .....	11
6. Communication data address list .....	12 ~ 17
7. Supplementary description .....	17 ~ 18
7-1 Measuring range list .....	17
7-2 Event type list .....	18
7-3 ASCII code list .....	18

**SHIMADEN CO., LTD.**

SR80C-1BE  
Aug. 2001

# 1. Outline

There are two types of communication systems, RS-232C and RS-485 employable as the SR80 series communication interface. Each of them is capable of setting various data for the SR80 and reading through a personal computer or the like, using signals which comply with EIA standards. RS-232C and RS-485 are data communication standards established by the Electronic Industries Association of the U.S. (EIA). The standards cover electrical and mechanical aspects, that is, matters related to applicable hardware but not the data transmission procedure of software. Therefore, it is not possible to communicate unconditionally with an apparatus which has the same interface. Hence, users need to have sufficient knowledge of specifications and transmission procedure.

When RS-485 is used, two or more of SR80 controllers can be connected to one another. There seems to be a limited number of personal computers, etc., which support this interface, but the use of a line converter for RS-232C <---> RS-485 creates stability.

# 2. Specifications

- Signal level : Following EIA'S RS-232C and RS-485
- Communication system : RS-232C 3-line half duplex system  
RS-485 2-line half duplex multidrop (bus) system
- Synchronization system : Half duplex start-stop synchronization system
- Communication distance : RS-232C 15 m maximum  
RS-485 maximum total of 500 m (differs depending on conditions.)
- Communication rate : 1200, 2400, 4800, 9600 and 19200bps
- Transmission procedure : No procedure
- Data format : Data 7 bits, even parity stop 1 bit  
Data 7 bits, even parity stop 2 bits  
Data 7 bits, no parity, stop 1 bit  
Data 7 bits, no parity, stop 2 bits  
Data 8 bits, even parity, stop 1 bit  
Data 8 bits, even parity, stop 2 bits  
Data 8 bits, no parity, stop 1 bit  
Data 8 bits, no parity, stop 2 bits
- Communication code : ASCII codes
- Isolation : Insulated between communication signals and various inputs, system and various outputs
- Other matters : SR82 and SR83 communication systems meet EMC standards on condition that clamp filters ZCAT2436-1330A-M, TDK products, are used appropriately.

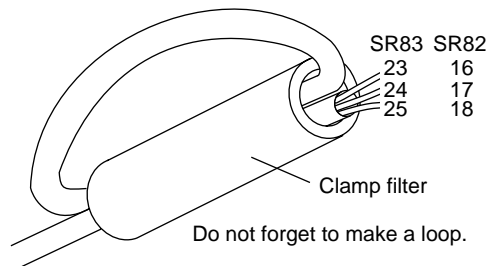

# 3. Connecting controller with host computer

The SR80 series controller is provided with only 3 lines for input and output, i.e., for data transmission, data reception and grounding for signals, not with any other signal lines. Since the controller has no control line, control signals should be taken care of on the host side.

In this instruction, an example of control signal processing methods is shown in drawings (portions surrounded by dotted lines). As the method depends on the system, however, you are advised to refer to the specifications of the host computer for details.

## 3-1 RS-232C

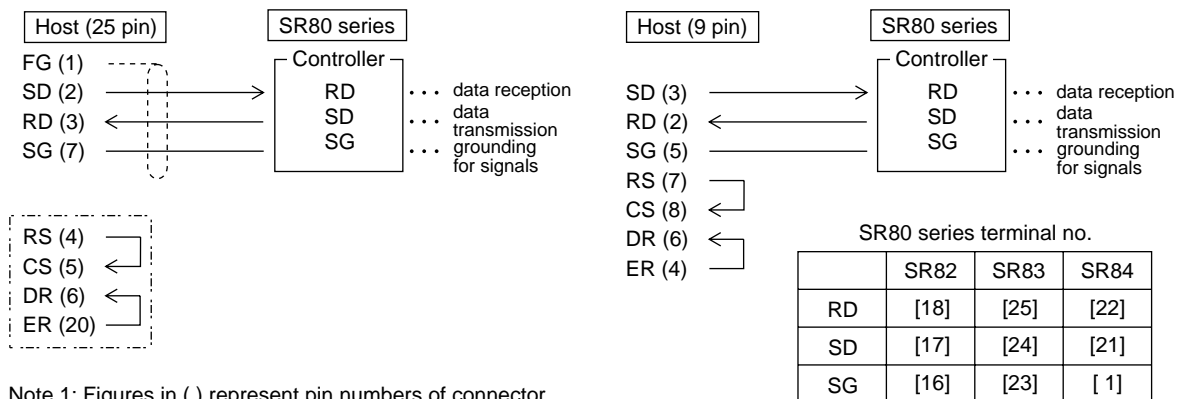

Note 1: Figures in ( ) represent pin numbers of connector.

### 3-2 RS-485

The input/output logical level of the SR80 controller is basically as follows:  
 In the mark state - terminal < + terminal  
 In the space state - terminal > + terminal

Until immediately before transmission, however, plus terminals and minus terminals of the controller have high impedance and outputs at the above levels are produced immediately before starting transmission. (See 3-3 3-state output control.)

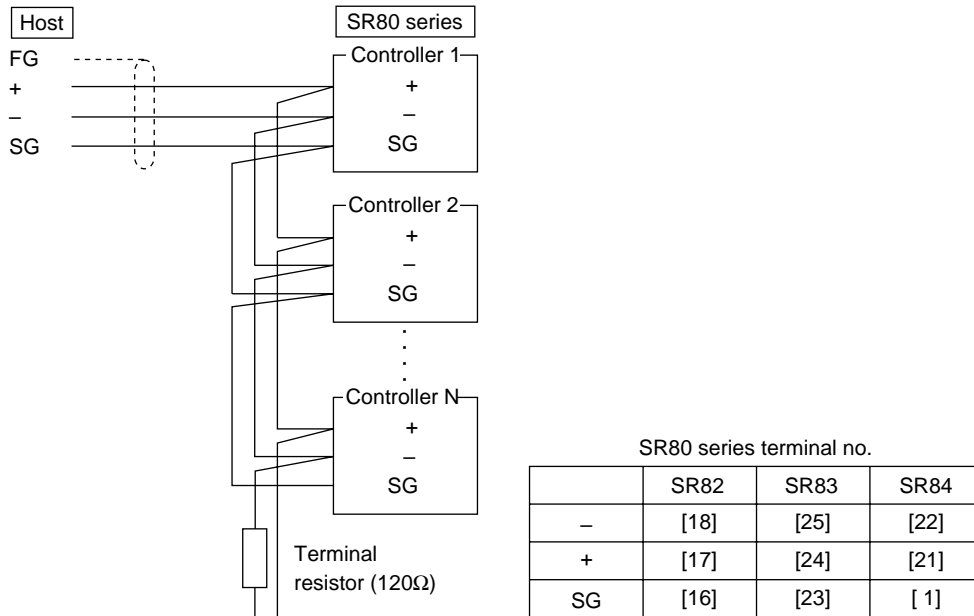

Note 1: In the case of RS-485, provide it with the attached terminal resistor of 1/2W, 120Ω across terminals + and - if necessary. Nevertheless, it should be provided to only the last controller. If two or more controllers are provided with terminal resistors, correct operation cannot be guaranteed.

### 3-3 3-state output control

Since RS-485 is of the multidrop system, transmission output has high impedance always while communication is not carried out or signals are being received in order to avoid collision between transmission signals. It changes from high impedance to the normal output condition immediately before transmission and returns to high impedance control simultaneously when transmission terminates. As the 3-state control is delayed by about 1 msec (maximum) from the completion of transmission of an end character end bit, however, a few microseconds' delay should be provided if the host side starts transmission immediately upon reception.

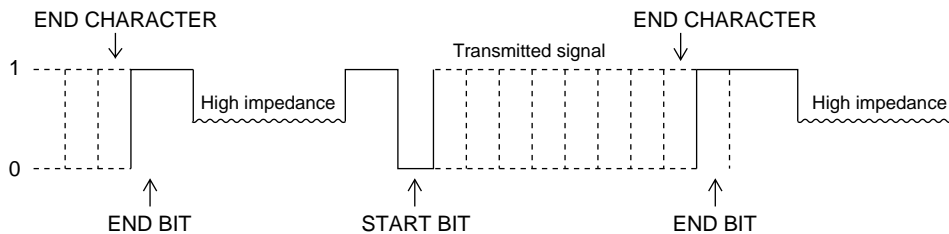

## 4. Setting of parameters related to communication

There are the following 8 communication-related parameters for the SR80 series controller. These parameters are unable to be set or changed by communication; use front key for setting and changing. When parameters are set, see 4-2. "Key Sequence" of the separate instruction manual for the controller and follow the described steps.

### 4-1 Communication mode selecting screen

1-29

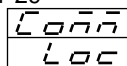

Initial value: Loc  
 Selectable range: Com→Loc

Select communication mode. Front key operation allows only change from COM to LOC, though.  
 Loc mode: Only read commands are valid in communication. (front COM Lamp OFF)  
 Com mode: Read and write commands are valid in communication. (front COM Lamp ON)

#### 4-2 Communication address setting screen

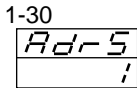

Initial value: 1  
Setting range: 1 ~ 99

While one SR80 controller is connected to one host computer in the case of 232C, RS-485 employs the multidrop system allowing it to be connected to a maximum of 32. Actually, however, communication has to be carried out bilaterally. Therefore, each instrument is assigned an address (machine No.) so that only the instrument with the designated address can answer.

Note 1: Addresses are from 01 to 99, which can be assigned to 32 instruments maximum.

#### 4-3 Communication rate setting screen

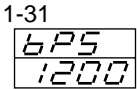

Initial value: 1200bps  
Setting range: 1200, 2400, 4800, 9600, 19200bps

Select a rate at which data are transmitted to host computer.

#### 4-4 Communication data format setting screen

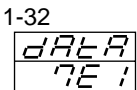

Initial value: 7E1  
Selectable range: 8 types listed in the following table

Select a communication data format from the following 8 types.

	Length of data	Parity	Stop bit		Length of data	Parity	Stop bit
7E1	7bit	EVEN	1bit	8E1	8bit	EVEN	1bit
7E2	7bit	EVEN	2bit	8E2	8bit	EVEN	2bit
7N1	7bit	None	1bit	8N1	8bit	None	1bit
7N2	7bit	None	2bit	8N2	8bit	None	2bit

#### 4-5 Communication control code setting screen

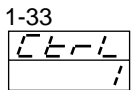

Initial value: 1  
Selectable range: 1 ~ 3

Set a control code to be used.

1. STX\_ETX\_CR
2. STX\_ETX\_CRLF
3. @:\_:CR

#### 4-6 Communication BCC check setting screen

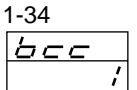

Initial value: 1  
Selectable range: 1 ~ 4

Select a BCC operation method to be used in BCC checking.

1. ADD
2. ADD\_two's cmp
3. XOR
4. None

#### 4-7 Communication memory mode selecting screen

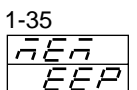

Initial value: EEP  
Selectable range: EEP, Ram, r\_E

Since the number of writing cycles of volatile memory EEPROM is fixed, the life of EEPROM is shortened if SV data or the like are rewritten frequently by communication. To prevent this, in case data are to be rewritten frequently by communication, set the RAM mode in which only RAM data are rewritten without rewriting EEPROM, thereby maintaining the life of EEPROM as long as possible.

- EEP mode: In this mode EEPROM data are also rewritten every time data are changed by communication. Accordingly, data are maintained when power is turned off.
- RAM mode: In this mode only RAM data are rewritten but EEPROM data are not when data are changed by communication. Therefore, RAM data are deleted when power is turned off. Upon applying power again, operation starts with data stored in EEPROM.
- r\_E mode: SV and OUT data are written in RAM. All other data are written in EEPROM.

#### 4-8 Communication delay time setting screen

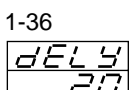

Initial value: 20  
Setting range: 0FF, 1 ~ 100

Set the length of delay time from receipt of a communication command to transmission.  
Delay time=0.512 × set value (msec)

Note 1: When RS-485 is used, some converters take longer time for 3-state control than others and it may lead to signal collision. This can be avoided by increasing delay time. Care should be taken particularly when the

communication rate is slow (1200bps or 2400bps).

Note 2: In case set value=0, internal operation is carried out with set value=1.

Note 3: Actual delay time from receipt of a communication command to transmission is a total of the above-mentioned delay time and command processing time by software. Particularly for writing commands, about 400 msec may be taken for processing.

## 5. Outline of standard serial communication protocols

### 5-1 Communication procedure

#### (1) Master/slave relation

- The master side means personal computer or PLC (host).
- The slave side means the SR80 series controller.
- A communication command from the master side starts communication and a response from the slave side terminates it. If abnormality such as a communication format error or a BCC error occurs, there will be no response. No response is sent, either, to broadcast instruction.

#### (2) Communication procedure

Communication goes on by transferring the transmission right to each other in the pattern that the slave side responds to the master side.

#### (3) Time-out

In case receipt of the end character does not complete within one second after receiving the start character, it is time-out and the controller is automatically put in the state of waiting for another command (a new start character). Accordingly, the host side should set a one second minimum as the time-out duration.

### 5-2 Communication format

The SR80 allows for a variety of communication formats (start character, text end character, end character and BCC operating method) and communication data formats (data bit length, whether or not of parity, and stop bit length) for easy compliance with other protocols.

Nonetheless, the following serves as their basic format and you are encouraged to use them uniformly:

#### • Communication format

Control code (start character, text end character, end character)→STX\_ETX\_CR

Check sum (BCC operating method)→Add

#### • Communication data format (data bit length, whether or not of parity, stop bit length)→7E1 or 8N1

For setting a communication format and a communication data format, see "4. Setting of parameters related to communication."

#### (1) Outline of communication format

The communication format comprises the basic format portion I, the text portion and the basic format portion II.

##### 1) Communication command format

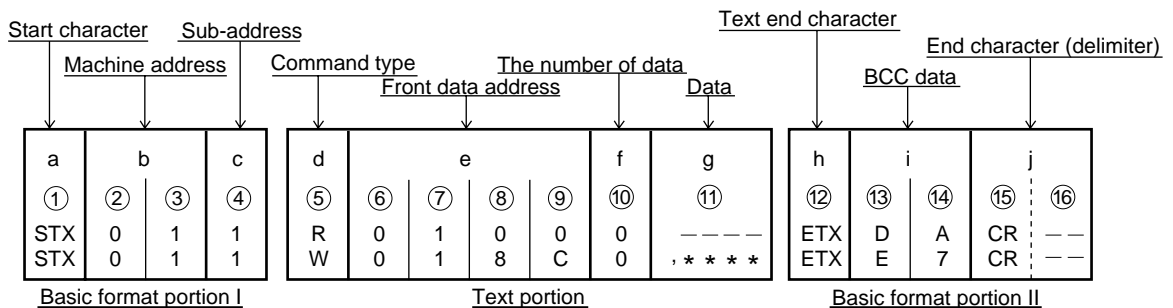

##### 2) Response format

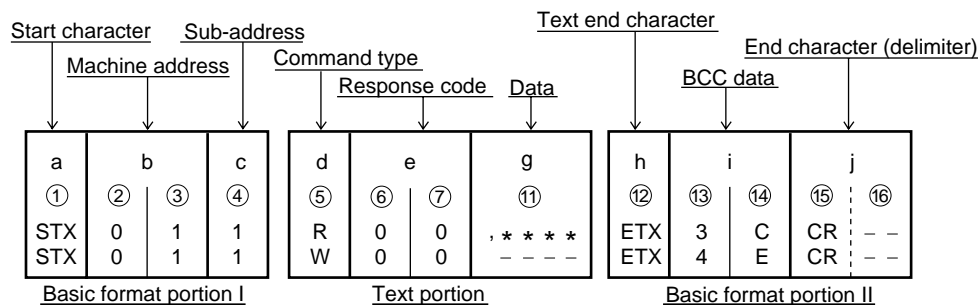

- The basic format portions I and II are common to read commands (R), write commands (W) and responses. Nonetheless, in BCC data of i (⑬, ⑭) operation result data is inserted each time.
- The text portion differs depending on the types of commands, data addresses, responses, etc.

(2) Details of basic format portion I

a : Start character [ ① : 1 digit / STX(02H) or "@"(40H) ]

- Indicates the start of communication bloc.
- Upon receipt of start character, it is judged as the first character of a new communication bloc.
- A start character and a text end character are selected in a pair.  
(See 4-5 Communication control code setting screen.)  
Select STX (02H) --- ETX (03H), or select "@"(40H) --- " : "(3AH).

b : Machine address [ ②, ③ : 2 digits ]

- Designates the instrument to communicate with.
- Address can be designated in a range from 1 to 99 (decimal numerals).
- Binary 8 bit data (1 : 0000 0001 ~ 99 : 0110 0011) are split into high position 4 bits and low position 4 bits and converted to ASCII data.  
②: ASCII data converted from the high position 4 bits.  
③: ASCII data converted from the low position 4 bits.
- Since the machine address=0 (30H, 30H) is used for broadcast instruction, it cannot be used as a machine address. As the SR80 series controller does not support broadcast instruction, address=0 has no response.

c : Sub-address [ ④ : 1 digit ]

- As the SR80 series are single loop controllers, their sub-address is fixed to ④ = 1 (31H).

Designation of any other address is taken as a sub-address error and there will be no response.

(3) Details of basic format portion II

h : Text end character [ ⑫ : 1 digit / ETX(03H) or " : "(3AH) ]

- Indicates that the text portion terminates right before this character.

i : BCC data [ ⑬, ⑭ : 2 digits ]

- BCC (Block Check Character) checks if there is any error in communication.
- There will be no response if BCC operation results in a BCC error.
- There are the following 4 types of BCC operation: (Type of BCC operation can be set on the front screen.)

(1) Add

Add operation is performed on every 1 character of ASCII data (1 byte) from the start character ① through the text end character ⑫.

(2) Add\_two's cmp

Add operation is performed on every 1 character of ASCII data (1 byte) from the start character ① through the text end character ⑫, and two's complement of the low position 1 byte of the operation result is taken.

(3) XOR

XOR (exclusive OR) operation is performed on every 1 character of ASCII data (1 byte) from the machine address ② right after the start character through the text end character ⑫.

(4) None

BCC operation is not performed. (⑬, ⑭ are omitted.)

- Regardless of the length of data bits (7 or 8), operation is carried out with 1 byte (8 bits) as a unit.
- The low position 1 byte data obtained as a result of the operations mentioned above is split into high position 4 bits and low position 4 bits and converted to ASCII codes.

⑬: ASCII date converted from high position 4 bits.

⑭: ASCII date converted from low position 4 bits.

Example 1: In the case of a read command (R) with "Add" set:

①	②	③	④	⑤	⑥	⑦	⑧	⑨	⑩	⑫	⑬	⑭	⑮	⑯
STX	0	1	1	R	0	1	0	0	0	ETX	D	A	CR	
02H +30H +31H +31H +52H +30H +31H +30H +30H +30H +03H = 1DAH														

Low position 1 byte of result of addition (1DAH)=DAH

⑬: "D"=44H, ⑭: "A" = 41H

Example 2: In the case of a read command (R) with "Add\_two's cmp" set:

①	②	③	④	⑤	⑥	⑦	⑧	⑨	⑩	⑫	⑬	⑭	⑮	⑯
STX	0	1	1	R	0	1	0	0	0	ETX	2	6	CR	
02H +30H +31H +31H +52H +30H +31H +30H +30H +30H +03H = 1DAH														

Low position 1 byte of result of addition (1DAH)=DAH

Two's complement of low position 1 byte (DAH)=26H

⑬: "2"=32H, ⑭: "6"=36H

Example 3: In the case of a read command (R) with "XOR" set:

①	②	③	④	⑤	⑥	⑦	⑧	⑨	⑩	⑫	⑬	⑭	⑮	⑯
STX	0	1	1	R	0	1	0	0	0	ETX	5	0	CR	
02H 30H ⊕31H ⊕31H ⊕52H ⊕30H ⊕31H ⊕30H ⊕30H ⊕30H ⊕03H = 50H														

• ⊕ = XOR (exclusive OR), though.

Low position 1 byte of result of operation (50H)=50H

⑬: "5"=35H, ⑭: "0"=30H

j : End character (delimiter) [ ⑮, ⑯ : 1 digit or 2 digits/CR or CR LF]

- Indicates that it is the end of communication message.
- End character can be selected from the following:
  - ⑮, ⑯ : CR (0DH)(CR only, LF is not added.)
  - ⑮, ⑯ : CR (0DH), LF (0AH)

(4) Basic format portions I and II common condition

1. If abnormalities as listed below are found in the basic format portions, there will be no response:

- There is a hardware error.
- Machine address or sub-address is different from that of the designated instrument.
- Any of the characters specified in the above communication format is not in its specified position.
- The result of BCC operation differs from BCC data.

2. Conversion of data: Every 4 bits of binary data are converted to ASCII data.

3. <A> through <F> in hexadecimal numbers are converted to ASCII data by using capital letters.

(5) Outline of text portion

The text portion changes according to the types of commands and responses. For details of the text portion, see 5-3 Details of read commands (R) and 5-4 Details of write commands (W).

d : Type of commands [ ⑤ : 1 digit ]

- "R" (52H/capital letter): Indicates that it is a read command or a response to read command. Used to read (take) various data of SR80 from personal computer, PLC, etc.
- "W" (57H/capital letter): Indicates that it is a write command or a response to write command. Used to write (change) various data in SR80 from personal computer, PLC, etc.
- "B" (42H/capital letter): Indicates that it is broadcast instruction. Since SR80 does not support broadcast instruction, this is unable to be used.
- There is no response when any other abnormal character besides "R" and "W" is recognized.

e : Front data address [ ⑥, ⑦, ⑧, ⑨ : 4 digits ]

- For a read command (R) or a write command (W), designates a front data address of where to read from or write in.
- A front data address is designated by binary number 16 bit (1 word/0 ~ 65535) data.
- 16 bit data are split into 4 bit groups and converted to ASCII data.

Binary numbers (16 bits)	D15, D14, D13, D12 0 0 0 0	D11, D10, D9, D8 0 0 0 1	D7, D6, D5, D4 1 0 0 0	D3, D2, D1, D0 1 1 0 0
Hexadecimal numbers (Hex)	0H " 0 "	1H " 1 "	8H " 8 "	CH " C "
ASCII data	30H ⑥	31H ⑦	38H ⑧	43H ⑨

- For data addresses, refer to 5-6 Details of communication data addresses.

f : The number of data [ ⑩ : 1 digit ]

- For a read command (R) or a write command (W), designates the number of data to be read or written.
- The number of data is designated in the following range by converting binary number 4 bit data to ASCII data: "0" (30H) (one) ~ "9" (39H) (ten)
- For write commands, the number is fixed to "0" (30H) (one).
- The actual number of data is <the number of data = designated numerical value of data + 1>.

g : Data [ ⑪ : The number of digits depends on the number of data.]

- Designates data to be written (data to be changed) for write command (W) or data to be read for response to a read command (R).
- The data format is as follows:

g (⑪)

" , " 2CH	First data				Second data				nth data			
	High position 1st digit	2nd digit	3rd digit	Low position 4th digit	High position 1st digit	2nd digit	3rd digit	Low position 4th digit	High position 1st digit	2nd digit	3rd digit	Low position 4th digit

- Data is always preceded by comma (", " 2CH) to show the subsequent portion is data.
- No punctuation code is used between data and data.
- The number of data is determined by the number of data (f: ⑩) of the communication command format.
- Each data is expressed by binary 16 bits (1 word), excluding a decimal point, as a unit. The position of decimal point is fixed in each data.
- 16 bit data are split into 4 bit groups and respectively converted to ASCII data.
- For details of data, refer to 5-3 Details of read commands (R) and 5-4 Details of write command (W).

e : Response code [ ⑥, ⑦ : 2 digits]

- Designates a response code to a read command (R) or a write command (W).
- Binary 8 bit data (0 ~ 255) are split to high position 4 bits and low position 4 bits and respectively converted to ASCII data.

⑥: ASCII data converted from high position 4 bits.

⑦: ASCII data converted from low position 4 bits.

- In the case of normal response, "0" (30H), "0" (30H) is designated.
- In the case of abnormal response, abnormal code No. is converted to ASCII data and designated.
- For details of response codes, refer to 5-5 Details of Response codes.

### 5-3 Details of read commands (R)

Read commands (R) are used by a personal computer, PLC or the like to read (take) various data in SR80.

(1) Read Command (R) format

- The format of the text portion of a read command (R) is shown below:  
(The basic format portions I and II are common to all commands and responses.)

Text portion

d	e				f
⑤	⑥	⑦	⑧	⑨	⑩
R	0	4	0	0	4
52H	30H	33H	30H	30H	34H

- d: Indicates that it is a read command.
- e: Designates the front data address of data to be read.
- f: Designates how many data (words) are to be read from the front data address.

- The above command means the following:  
 Front data address of data to be read = 0400H (hexadecimal)  
 = 0000 0100 0000 0000 (binary)  
 The number of data to be read = 4H (hexadecimal)  
 = 0100 (binary)  
 = 4 (decimal)  
 (The actual number of data) = Five (4 + 1)  
 Thus, the command designates reading of five data from the data address 0400H.

(2) Normal response format to read command (R)

- The following is the normal response format (text portion) to read commands (R):  
(The basic format portions I and II are common to all commands and responses.)

Text portion

d	e		g												
⑤	⑥	⑦	first data				second data				5th data				
R	0	0	,	0	0	1	E	0	0	7	8				
52H	30H	30H	2CH	30H	30H	31H	45H	30H	30H	37H	38H				
												0	0	0	3
												30H	30H	30H	33H

- d(⑤): <R (52H)> indicating that it is a response to a read command (R) is inserted.
- e(⑥, ⑦): The response code <0 0 (30H, 30H)> indicating that it is a normal response to the read command (R) is inserted.
- g(⑪): Response data to the read command is inserted.  
 The data format is as follows:
  - To begin with, <(2CH)> indicating the head of data is inserted.
  - Then, data in the number according to <the number of data to be read> are inserted one by one, starting from the <data of the front data address for reading>.
  - Nothing is inserted between the respective data.
  - The respective data comprise binary 16 bits (1 word) data, excluding a decimal point, and are converted, 4 bits as a unit, to ASCII data and inserted.
  - The position of decimal point is fixed in the respective data.
  - The number of characters of response data is as follows:  
 Number of characters = 1 + 4 × number of data to be read
- To the above read command (R), the following data are returned one by one as response data:

Data address 16 bits (1 word)	Data 16 bits (1 word)	
	Hexadecimal	Hexadecimal    decimal
0	0400	001E    30
1	0401	0078    120
2	0402	001E    30
3	0403	0000    0
4	0404	0003    3
	0405	0000    0
	0406	03E8    1000
	0407	0028    40

Data address (0400H) →

The number of data to be read (4H: five)

Thus, the above data can be read.

(3) Abnormal response format to read command (R)

- The following is the abnormal response format (text portion) to read commands (R):  
(The basic format portions I and II are common to all commands and responses.)

Text Portion

d	e	
⑤	⑥	⑦
R	0	7
52H	30H	37H

- d(⑤): <R (52H)> indicating that it is a response to a read command (R) is inserted.
- e(⑥, ⑦): A response code indicating that it is an abnormal response to the read command (R) is inserted.
- For details of abnormal response code, refer to 5-5 Details of response codes.
- No response data are inserted in an abnormal response.

#### 5-4 Details of write commands (W)

A write command is used by a personal computer, PLC, etc. to write (change) various data in SR80.

To use a write command, the COMM mode has to be selected on the 4-1 Communication mode selecting screen. As this parameter is unable to be changed from LOC to COM by front key operation, however, the change should be made by the following command transmission: (in the case of Address=01, Sub-address=1, Control code=STX\_ETX\_CR, and Check sum=Add.)

Command format

STX	0	1	1	W	0	1	8	C	0	,	0	0	0	1	ETX	E	7	CR
02H	30H	31H	31H	57H	30H	31H	38H	43H	30H	2CH	30H	30H	30H	31H	03H	45H	37H	0DH

Once the above command is transmitted and a normal response is returned, the COM LED lamp on the front panel lights and mode is changed to communication.

(1) Write command (W) format

- The following is the text format of a write command.  
(The basic format portions I and II are common to all commands and responses.)

Text Portion

d	e				f	g				
⑤	⑥	⑦	⑧	⑨	⑩	⑪				
W	0	4	0	0	0	Data to be written				
57H	30H	34H	30H	30H	30H	,	0	0	2	8
						2CH	30H	30H	32H	38H

- d: Indicates that it is a write command. It is fixed to "W" (57H).
- e: Designates the front data address of data to be written (changed).
- f: Designates the number of data to be written (changed).
- g: Designates data to be written (changed).
  - To begin with, <, (2CH)> indicating the head of data is inserted.
  - Then, data to be written (changed) are inserted.

3. The respective data comprise binary 16 bits (1 word) data, excluding a decimal point, and are converted, 4 bits as a unit, to ASCII data and inserted.

4. The position of decimal point is fixed in the respective data.

- The above command means the following:

Front data address of data to be written = 0400H (hexadecimal)  
 = 0000 0100 0000 0000 (binary)  
 The number of data to be written = 0H (hexadecimal)  
 = 0000 (binary)  
 = 0 (decimal)

(The actual number of data) = one (0+1)

Data to be written = 0028H (hexadecimal)  
 = 0000 0000 0010 1000 (binary)  
 = 40 (decimal)

Thus, writing (changing) of data address 0400H and one piece of data (40: decimal) is designated.

		Data address 16 bits (1 word)		Data 16 bits (1 word)	
		Hexadecimal	Decimal	Hexadecimal	Decimal
Address (400H) → 0 The number of data to be written: one (0H)		0400	1024	0028	40
		0401	1025	0078	120
		0402	1026	001E	30

- (2) Normal response format to write command (W)

- The following is the normal response format (text portion) to a write command (W).  
 (The basic format portions I and II are common to all commands and responses.)

text portion

d ⑤	e ⑥   ⑦	
W 57H	0 30H	0 30H

- d(⑤): <W (57H)> indicating that it is a response to a write command (W) is inserted.
- e(⑥, ⑦): A response code <00 (30H, 30H)> indicating that it is a normal response to the write command (W) is inserted.

- (3) Abnormal response format to write command (W)

- The following is the abnormal response format (text portion) to a write command (W).  
 (The basic format portions I and II are common to all commands and responses.)

text portion

d ⑤	e ⑥   ⑦	
W 57H	0 30H	9 39H

- d(⑤): <W (57H)> indicating that it is a response to a write command (W) is inserted.
- e(⑥, ⑦): A response code indicating that it is an abnormal response to the write command (W) is inserted.
- For details of abnormal codes, refer to 5-5 Details of response codes.

## 5-5 Details of response codes

- (1) Types of response codes

- Communication responses to read commands (R) and write commands (W) always contains response codes.
- Response codes are divided broadly into two types:

Response codes { Normal response codes  
 Abnormal response codes

- A response code comprises 8 bits data of binary numbers (0 ~ 255).
- The types of response codes are listed below:

### A List of Response Codes

Response code		Type of code	Description
Binary numbers	ASCII		
0000 0000	"0", "0" : 30H, 30H	Normal response	Normal response to read command (R) or write command (W)
0000 0001	"0", "1" : 30H, 31H	Hardware error in text portion	When a hardware error such as framing overrun or parity error has been detected in data in the text portion.
0000 0111	"0", "7" : 30H, 37H	Format error of text portion	Format of text portion is different from what was fixed.
0000 1000	"0", "8" : 30H, 38H	Error in data of text portion, data address or the number of data	Data of text portion is not in fixed format, or data address or the number of data is different from designated one.
0000 1001	"0", "9" : 30H, 39H	Data error	Data to be written get beyond range in which setting is possible.
0000 1010	"0", "A" : 30H, 41H	Execution command error	Execution command (such as AT command) was received in conditions where that execution command is not acceptable.
0000 1011	"0", "B" : 30H, 42H	Write mode error	Some types of data are unable to be changed at certain points in time. Write command containing such data was received at such a time.
0000 1100	"0", "C" : 30H, 43H	Specification or option error	Write command containing data of specification or option which was not added was received.

(2) Priority order of response codes

The smaller the value of response code, the higher the priority of the response code; When two or more response codes are generated, a response code of higher priority order is returned.

### 5-6 Details of communication data addresses

(1) Data address and read/write

- In a data address, binary numbers (16 bit data) are expressed by hexadecimal numbers, with 4 bits as a unit.
- R/W means that data are capable of being read and written.
- R means that data are only for reading.
- W means that data are only for writing.
- In case a data address only for writing is designated by a read command (R), or a data address only for reading is designated by a write command (W), it results in a data address error and the abnormal response code "0", "8" (30H, 38H) "error in data format, data address or the number of data in text portion" is returned.

(2) Data address and the number of data

- If a data address which is not included in the data addresses for SR80 is designated as the front data address, it results in a data address error, and the abnormal response code "0", "8" (30H, 38H) "error in data format, data address or the number of data in text portion" is returned.
- Even when a front data address is included in the data address list, the data address added with the number of data gets out of the data address list, it results in an error of the number of data, and abnormal response code "0", "8" (30H, 38H) " is returned.

(3) Data

- Since data comprise binary numbers (16 bit data) without a decimal point, the form of data, whether there is a decimal point or not, etc., have to be confirmed. (See the instruction manual of the instrument itself.)

Example: How to express data with decimal point  
Hexadecimal data

20.0% → 200 → 00C8

- In data of which the unit is UNIT, the position of decimal point depends on the measuring range.
- In other data than the above, binary numbers with code (16 bit data: -32768 ~ 32767) are used.

Example: How to express 16 bit data

Data with code		Data without code	
Decimal	Hexadecimal	Decimal	Hexadecimal
0	0000	0	0000
1	0001	1	0001
⋮	⋮	⋮	⋮
32767	7FFF	32767	7FFF
-32768	8000	32768	8000
-32767	8001	32769	8001
⋮	⋮	⋮	⋮
-2	FFFE	65534	FFFE
-1	FFFF	65535	FFFF

(4) <Reserved> in parameter portions

- When a <reserved> portion is read in reply to a read command, the (0000 H) data are returned.
- When a <reserved> portion is written in reply to a write command, normal response code "0", "0" (30H, 30H) is returned but no data is rewritten.

(5) Option-related parameters

- When the data address of a parameter which is not added as an option is designated, abnormal response code "0", "C" (30H, 43H)"Specification, option error" is returned to a read command (R) as well as a write command (W). If an address of data only for reading is read, however, the (0000H) data are returned.

(6) Parameters not shown in front panel displays owing to action specifications or setting specifications

- Even parameters which are not shown (used) on the front panel displays owing to action specifications or setting specifications are possible to be read and written in communication.

## 6. Communication data address list

Data address (hex)	Parameter	Details of parameter	R/W
0040		Series code 1	R
0041		Series code 2	R
0042		Series code 3	R
0043		Series code 4	R

- The address areas listed above become product ID data areas and data are ASCII data, 8 bits as a unit. Therefore, one address represents two data.
- A series code is expressed by 8 data maximum and a surplus area is filled with 00H data.

Example 1) SR80

Address	H	L	H	L
0040	"S"	, "R"	53H	, 52H
0041	"8"	, "0"	38H	, 30H
0042	"3"	, 00H	30H	, 30H
0043	00H	, 00H	30H	, 30H

- Code selection data are expressed by 56 data maximum and a surplus area is filled with 00H data.

Data address (hex)	Parameter	Details of parameter	R/W
0100	PV_W	Measured value	R
0101	SV_W	Execution SV value	R
0102	OUT1W	Control output 1 value	R
0103	OUT2W	Control output 2 value (without option = 0000H)	R
0104	EXE_FLG	Action flag (bit without action = 0)	R
0105	EV_FLG	Event output flag (without option = 0000H)	R
0106	SV No.	Execution SV No. 0=SV1, 1=SV2, SB, REM	R
0107	EXE_PID	Execution PID No. 0=PID1, 1=PID2	R
0108	REM_W	Remote input value (without remote input function = 0000H)	R
0109	HB_W	HB current value (without option = 0000H)	R
010A	HL_W	HL current value (without option =0000H)	R
010B	DI_FLG	DI input status flag (without option = 0000H)	R

0111	RANGE	Measuring range (See "7-1 Measuring range list.")	R
0112	CJ	Cold contact compensation 0=INT, 1=EXT	R
0113	DP	Position of decimal point 0=non, 1= <input type="text"/> , 2= <input type="text"/> , 3= <input type="text"/>	R
0114	SC_L	Lower limit value of measuring range	R
0115	SC_H	Higher limit value of measuring range	R

- EXE\_FLG, EV\_FLG, DI\_FLG Details are shown below.

	D15	D14	D13	D12	D11	D10	D9	D8	D7	D6	D5	D4	D3	D2	D1	D0
EXE_FLG	: 0	0	0	0	0	REM/L	AT/W	COM	STOP	RMP	ESV	SB	REM	STBY	MAN	AT
EV_FLG	: 0	0	0	0	0	0	0	0	0	0	0	0	0	EV3	EV2	EV1
DI_FLG	: 0	0	0	0	0	0	0	0	0	0	0	0	0	0	DI2	DI1

- Higher limit side PV\_SO, CJ\_SO, b ---, REM\_SO, HB\_SO = 7FFFH
- Lower limit side PV\_SO, CJ\_SO, c ---, REM\_SO, HB\_SO = 8000H
- Invalid data for HB and HL=7FFEh

Data address (hex)	Parameter	Details of parameter	R/W
0180	SV_NO	Setting of execution SV No. (change)	W
0181	SV_QNO	Setting of executionSV No. (Without RMP change)	W
0182	OUT1_W	Control output 1, Set value in MAN operation	W
0183	OUT2_W	Control output2, Set value in MAN operation	W
0184	AT	0=No execution, 1=Execution	W
0185	MAN	0=AUTO, 1=MAN	W
0186	STBY	0=EXEC, 1=STBY	W
0187	REM	0=SV, 1=RSV	W
0188	SB	0=OFF, 1=ON	W
0189	Reserved		W
018A	Reserved		W
018B	STOP	0=RUN, 1=STOP	W
018C	COM	0=LOC, 1=COM	W

0300	SV1	Set value 1	R/W
0301	SV2	Set value 2	R/W

Data address (hex)	Parameter	Details of parameter	R/W
030A	SV_L	Set value limiter on lower limit side	R/W
030B	SV_H	Set value limiter on higher limit side	R/W
030C	RAMP_UP	Ascending ramp setting	R/W
030D	RAMP_DW	Descending ramp setting	R/W
030E	RAMP_UNT	Ramp unit setting	0=SEC, 1=MIN
030F	RAMP_RTE	Ramp multiple setting	0= × 1, 1= × 0.1

0311	SB	Set value bias setting	R/W
0312	SV_MD	SV/SB setting mode	0=non, 1=SV, 2=SB
0313	Reserved		R/W
0314	REM_L	Lower side remote scale	R/W
0315	REM_H	Higher side remote scale	R/W
0316	REM_B	Remote bias	R/W
0317	REM_F	Remote filter	R/W
0318	REM_T	Remote tracking	0=No, 1=YES

031D	REM_P	Remote point setting	R/W
031E	REM_D	Remote point hysteresis setting	R/W

0400	PB	SV1 control output 1 proportional band	R/W
0401	IT	SV1 control output1 integral time	R/W
0402	DT	SV1 control output1 derivative time	R/W
0403	MR	SV1 manual reset	R/W
0404	DF	SV1 Hysteresis	R/W
0405	0_L	SV1 control output 1 lower output limiter	R/W
0406	0_H	SV1 control output 1 higher output limiter	R/W
0407	SF	SV1 control output 1 target value function	R/W
0408	PB21	SV2/SB, remote control output 1 proportional band	R/W
0409	IT21	SV2/SB, remote control output 1 integral time	R/W
040A	DT21	SV2/SB, remote control output 1 derivative time	R/W
040B	MR21	SV2/SB, remote manual reset	R/W
040C	DF21	SV2/SB, remote hysteresis	R/W
040D	021L	SV2/SB, remote control output 1 lower output limiter	R/W
040E	021H	SV2/SB, remote control output 1 higher output limiter	R/W
040F	SF21	SV2/SB, remote control output 1 target value function	R/W

Data address (hex)	Parameter	Details of parameter	R/W
0460	PB_2	SV1 control output 2 proportional band	R/W
0461	IT_2	SV1 control output 2 integral time	R/W
0462	DT_2	SV1 control output 2 derivative time	R/W
0463	DB_2	SV1 dead band	R/W
0464	DF_2	SV1 Hysteresis	R/W
0465	0_2L	SV1 control output 2 lower output limiter	R/W
0466	0_2H	SV1 control output 2 higher output limiter	R/W
0467	SF_2	SV1 control output 2 target value function	R/W
0468	PB22	SV2/SB, remote control output 2 proportional band	R/W
0469	IT22	SV2/SB, remote control output 2 integral time	R/W
046A	DT22	SV2/SB, remote control output 2 derivative time	R/W
046B	DB22	SV2/SB, remote dead band	R/W
046C	DF22	SV2/SB, remote hysteresis	R/W
046D	022_L	SV2/SB, remote control output 2 lower output limiter	R/W
046E	022_H	SV2/SB, remote control output 2 higher output limiter	R/W
046F	SF22	SV2/SB, remote control output 2 target value function	R/W

Data address (hex)	Parameter	Details of parameter	R/W
0500	EV1_MD	Event 1 mode See "7-2 Event type list."	R/W
0501	EV1_SP	Event 1 set value See "7-2 Event type list."	R/W
0502	EV1_DF	Event 1 hysteresis	R/W
0503	EV1_STB	Event 1 stand-by actions oFF: Alarm action without stand-by 1: Alarm action with stand-by (while power is ON) 2: Alarm action with stand-by (while power is ON, during execution of stand-by) 3: Alarm action with stand-by (while power is ON, during execution of stand-by, and with SV change) 4: Control action without stand-by	R/W
0504	EV1_TM	Event 1 delay time	R/W
0505	Reserved		R/W
0506	Reserved		R/W
0507	Reserved		R/W
0508	EV2_MD	Event 2 mode See "7-2 Event type list."	R/W
0509	EV2_SP	Event 2 set value See "7-2 Event type list."	R/W
050A	EV2_DF	Event 2 hysteresis	R/W
050B	EV2_STB	Event 2 stand-by actions oFF: Alarm action without stand-by 1: Alarm action with stand-by (while power is ON) 2: Alarm action with stand-by (while power is ON, during execution of stand-by) 3: Alarm action with stand-by (while power is ON, during execution of stand-by, and with SV change) 4: Control action without stand-by	R/W
050C	EV2_TM	Event 2 delay time	R/W
050D	Reserved		R/W
050E	Reserved		R/W
050F	Reserved		R/W
0510	EV3_MD	Event 3 mode See "7-2 Event type list."	R/W
0511	EV3_SP	Event 3 set value See "7-2 Event type list."	R/W
0512	EV3_DF	Event 3 hysteresis	R/W
0513	EV3_STB	Event 3 stand-by actions oFF: Alarm action without stand-by 1: Alarm action with stand-by (while power is ON) 2: Alarm action with stand-by (while power is ON, during execution of stand-by) 3: Alarm action with stand-by (while power is ON, during execution of stand-by, and with SV change) 4: Control action without stand-by	R/W
0514	EV3_TM	Event 3 delay time	R/W

0580	DI1	DI 1 assignment	0=noP, 1=Stb, 2=SV/Sb, 3=At, 4=mAn, 5=dA,	R/W
0581	DI2	DI 2 assignment	6=StP, 7=rEm	R/W

0590	HBS	Heater break alarm setting		R/W
0591	HBL	Heater loop alarm setting		R/W
0592	HBM	Heater break alarm mode setting	0=Lock, 1=rEAL	R/W

05A0	A01_MD	Analog output mode	0=Pv, 1=SV, 2=dEV, 3=OUT1, 4=OUT2	R/W
05A1	A01_L	Anlog output scale on lower limit side		R/W
05A2	A01_H	Analog output scale on higher limit side		R/W

05B0	COM_MEM	Communication memory mode	0=EeP, 1=RAM, 2=r_E	R/W
------	---------	---------------------------	---------------------	-----

Data address (hex)	Parameter	Details of parameter	R/W
0600	ACTMD	Output characteristics 0=rA, 1=dA	R/W
0601	01_CYC	SV1 proportional cycle	R/W
0602	ERROUT1	SV1 error output	R/W
0603	Reserved		R/W
0604	02_CYC	SV2 proportional cycle	R/W
0605	ERROUT2	SV2 error output	R/W

0610	ATP	AT point	R/W
0611	KLOCK	Keylock 0=OFF, 1=Except SV, AT and MAN, 2=Except SV, 3=All	R/W

0701	PV_B	PV bias	R/W
0702	PV_F	PV filter	R/W

## 7. Supplementary description

### 7-1 Measuring range list

	Input type	Code	Measuring range	Code	Measuring range
Thermocouple	*1 B	01	0 ~ 1800 °C	15	0 ~ 3300 °F
	R	02	0 ~ 1700 °C	16	0 ~ 3100 °F
	S	03	0 ~ 1700 °C	17	0 ~ 3100 °F
	K1	04	-100.0 ~ 400.0 °C	18	-150 ~ 750 °F
	K2	05	0.0 ~ 800.0 °C	19	0 ~ 1500 °F
	K3	06	-200 ~ 1200 °C	20	-300 ~ 2200 °F
	E	07	0 ~ 700 °C	21	0 ~ 1300 °F
	J	08	0 ~ 600 °C	22	0 ~ 1100 °F
	T	09	-199.9 ~ 200.0 °C	23	-300 ~ 400 °F
	N	10	0 ~ 1300 °C	24	0 ~ 2300 °F
	PLII	11	0 ~ 1300 °C	25	0 ~ 2300 °F
	WRe5-26	12	0 ~ 2300 °C	26	0 ~ 4200 °F
	U	13	-199.9 ~ 200.0 °C	27	-300 ~ 400 °F
	L	14	0 ~ 600 °C	28	0 ~ 1100 °F
	K			29	10.0 ~ 350.0 K
	AuFe-Cr			30	0.0 ~ 350.0 K
K			31	10 ~ 350 K	
AuFe-Cr			32	0 ~ 350 K	
R.T.D.	Pt100 (New) JIS/IEC	01	-200 ~ 600 °C	17	-300 ~ 1100 °F
		02	-100.0 ~ 100.0 °C	18	-150.0 ~ 200.0 °F
		03	-100.0 ~ 300.0 °C	19	-150 ~ 600 °F
		04	-50.0 ~ 50.0 °C	20	-50.0 ~ 120.0 °F
		05	0.00 ~ 50.00 °C	21	0.0 ~ 120.0 °F
		06	0.0 ~ 100.0 °C	22	0.0 ~ 200.0 °F
		07	0.0 ~ 200.0 °C	23	0.0 ~ 400.0 °F
		08	0.0 ~ 500.0 °C	24	0 ~ 1000 °F
	JPt100 (Old) JIS	09	-200 ~ 500 °C	25	-300 ~ 1000 °F
		10	-100.0 ~ 100.0 °C	26	-150.0 ~ 200.0 °F
		11	-100.0 ~ 300.0 °C	27	-150 ~ 600 °F
		12	-50.0 ~ 50.0 °C	28	-50.0 ~ 120.0 °F
		13	0.00 ~ 50.00 °C	29	0.0 ~ 120.0 °F
		14	0.0 ~ 100.0 °C	30	0.0 ~ 200.0 °F
		15	0.0 ~ 200.0 °C	31	0.0 ~ 400.0 °F
		16	0.0 ~ 500.0 °C	32	0 ~ 1000 °F
mV	-10 ~ 10	01	Owing to scaling function, any measuring range can be set within the following range.  Scaling range: -1999 to 9999 counts Span : 10 to 5000 counts on condition of lower side < higher side, though.		
	0 ~ 10	02			
	0 ~ 20	03			
	0 ~ 50	04			
	10 ~ 50	05			
	0 ~ 100	06			
V	-1 ~ 1	01	*1 Thermocouple B: Accuracy cannot be guaranteed on temperatures below 400 °C and 750 °F.		
	0 ~ 1	02			
	0 ~ 2	03			
	0 ~ 5	04			
	1 ~ 5	05			
	0 ~ 10	06			
mA	0 ~ 20	01			
	4 ~ 20	02			

## 7-2 Event type list

Event type	Event type	Setting range for event setting values	Initial value of event setting value
① $A_{H\bar{L}}$	Higher limit absolute value	Within measuring range	Higher value of setting range
② $A_{L\bar{O}}$	Lower limit absolute value	Within measuring range	Lower value of setting range
③ $d_{H\bar{L}}$	Higher limit deviation value	-1999 ~ 9999 Unit	2000 Unit
④ $d_{L\bar{O}}$	Lower limit deviation value	-1999 ~ 9999 Unit	-1999 Unit
⑤ $d_{\bar{O}}$	Out of higher/lower limit range	0 ~ 9999 Unit	2000 Unit
⑥ $d_{\bar{L}}$	Within higher/lower limit range	0 ~ 9999 Unit	2000 Unit
⑦ $Sc\bar{O}$	Scale-over	EV output continues despite scale-over.	
⑧ $H\bar{b}$	Heater break	EV output continues despite heater break alarm.	

## 7-3 ASCII code list

	b7b6b5	000	001	010	011	100	101	110	111
b4 ~ b1		0	1	2	3	4	5	6	7
0000	0	NUL	TC7 (DLE)	SP	0	@	P	`	p
0001	1	TC1 (SOH)	DC1	!	1	A	Q	a	q
0010	2	TC2 (STX)	DC2	”	2	B	R	b	r
0011	3	TC3 (ETX)	DC3	#	3	C	S	c	s
0100	4	TC4 (EOT)	DC4	\$	4	D	T	d	t
0101	5	TC5 (ENQ)	TC8 (NAK)	%	5	E	U	e	u
0110	6	TC6 (ACK)	TC9 (SYN)	&	6	F	V	f	v
0111	7	BEL	TC10 (ETB)	'	7	G	W	g	w
1000	8	FE0 (BS)	CAN	(	8	H	X	h	x
1001	9	FE1 (HT)	EM	)	9	I	Y	i	y
1010	A	FE2 (LF)	SUB	*	:	J	Z	j	z
1011	B	FE3 (VT)	ESC	+	;	K	[	k	{
1100	C	FE4 (FF)	IS4 (FS)	,	<	L	\	l	
1101	D	FE5 (CR)	IS3 (GS)	-	=	M	]	m	}
1110	E	SO	IS2 (RS)	.	>	N	^	n	~
1111	F	SI	IS1 (US)	/	?	O	_	o	DEL

—MEMO—

—MEMO—

Distributed in New Zealand by:

***Intech*** INSTRUMENTS LTD

Christchurch	Auckland	<a href="http://www.intech.co.nz">www.intech.co.nz</a>
Ph: +6433430646	098271930	<a href="mailto:sales@intech.co.nz">sales@intech.co.nz</a>
Fx: +6433430649	098271931	

The contents of this manual are subject to change without notice.

Temperature and Humidity Control Specialists

**SHIMADEN CO., LTD.**

Head Office: 2-30-10 Kitamachi, Nerima-Ku, Tokyo 179-0081 Japan

Phone: +81-3-3931-7891 Fax: +81-3-3931-3089

E-MAIL: [exp-dept@shimaden.co.jp](mailto:exp-dept@shimaden.co.jp) URL: <http://www.shimaden.co.jp>

PRINTED IN JAPAN