

SR80 Series Digital Controller

Instruction Manual

Thank you for purchasing the Shimaden SR80 series digital controller.

Please check that the delivered product is the correct item you ordered. Please do not begin operating this product until you have read this instruction manual thoroughly and understand its contents.

"Notice"

Please ensure that this instruction manual is made accessible to the final user of this instrument.

Preface

This instruction manual is provided for those who will be involved in the wiring, installation, operation and routine maintenance of the SR80 series (SR82, SR83 and SR84). This manual describes the care, installation, wiring, function and operating procedure of the SR80 series. Keep this manual at the work site during operation of the SR80 series. While using this instrument, you should always follow the guidance provided herein.

For matters concerning safety, potential damage to equipment and/or facilities, additional instructions and notes are indicated by the following headings:

Indicates matters which may result in accidents leading to injury or death if proper attention is neglected.

⚠ WARNING

Indicates matters which may result in damage to equipment and/or facilities.

⚠ CAUTION

Indicates that additional instructions and notes have been provided.

NOTE

The mark \oplus represents a protective conductor terminal. Ensure that it is grounded properly.

Matters to be attended to for safety's sake:

⚠ WARNING

The SR80 series controllers are designed for controlling temperature, humidity and other physical subjects of general industrial equipment. You must not employ this series for the control of any device potentially having a serious effect on human life without employing adequate and effective safety measures. We assume no responsibility for any accident arising from the use of this product without first taking effective safety measures.

⚠ WARNING

- The instrument should be installed, for example, in a control panel to prevent its terminal portion from accidental contact with a human body during its operation.
- The instrument should not be pulled out from its case. Never place your hand or an electric conductor inside it as such act may cause an electric shock resulting in serious injury or death.
- Make sure to ground the protective conductor (earth) terminal prior to using the instrument.

⚠ CAUTION

In the event a potential failure of the instrument could cause damage to the connected equipment, facilities or products, safety measures such as installing a fuse or an overheating protection device must be taken prior to the use of the instrument. We assume no responsibility for any accident which may occur as a result of not employing appropriate safety measures.

⚠ CAUTION

- The \triangle mark on the plate affixed to the instrument: On the terminal nameplate affixed to the case of the instrument, the \triangle mark has been printed. This is to warn you of the risk of electric shock which may result if the charger is touched while it is energized.
- In the external power circuit to be connected to the power terminal of the instrument, a switch or a breaker as means to turn power off must be installed. Such a switch or a breaker should be fixed adjacently to the instrument so that it can be operated with ease, and with an indication that it is a means to turn power off. Use a switch or a breaker which meets the requirements of IEC947.
- Fuse: Since the instrument does not have a built-in fuse, make sure to install a fuse in the power circuit to be connected to the power terminal. The fuse should be positioned between the switch or the breaker and the instrument and be attached to the L side of the power terminal.
Fuse rating/type: 250V AC 0.5 A/medium lagged or lagged type.
Use a fuse which meets IEC127 requirements.
- In the wiring operation, make sure to fasten terminal connections.
- Power voltage and frequency must be within their rated ranges.
- Voltage/current of a load to be connected to the output terminal and the alarm terminal should be within a rated range. If it goes out of the range, a rise in temperature will reduce the product life and/or result in problems with the product.
The output terminal should be connected with a device which meets IEC1010 requirements.
- Voltage/current out of its specified range should not be applied to the input terminal. It may reduce the product life and/or result in problems with the product.
For the rated voltage/current, refer to "7. Specifications."
In case input is of voltage (mV or V) or current (4-20 mA), the input terminal should be connected with a device which meets IEC1010 requirements.
- The SR80 series controller is provided with a draft hole. Take care to prevent metal or other foreign matter from entering into it. Failure to do so may cause problems with the instrument or even fire.

- Do not block the draft hole and maintain it free from dust and dirt. A rise in temperature or insulation failure may result in a shortening of the product life and/or problems with the instrument. For spaces required to be kept in its installation, see "2-3. Drawings showing external dimensions and panel cutout."
- It should be noted that repeated tolerance tests against voltage, noise, surge, etc. may lead to deterioration of the instrument.
- Users are prohibited from modifying the instrument and using it in an anomalous way.
- When employing the instrument, you are requested to observe matters to be attended to as described in the instruction manual concerning safe and correct operation of the instrument in order to use it safely while maintaining its reliability.

1. Introduction

1-1. Check before use

This product is fully checked for quality assurance prior to shipment. Nevertheless, you are requested to ensure that there is no error, damage or missing components by confirming the model codes and checking the external view of the product and the number of items attached.

Confirmation of model codes:

Check the model codes stuck to the case of the product to confirm that the respective codes represent what was specified when you ordered the product, referring to the following table of codes:

□-□□-□-□□-□□□□□
 ① ② ③ ④ ⑤ ⑥ ⑦ ⑧ ⑨ ⑩ ⑪

Item	Code and description
① Series	SR82, SR83, SR84
② Input	1: Thermocouple 2: R.T.D. 3: Voltage (mV) 4: Current (4-20mA) 6: Voltage (V)
③ Output 1	Y: Contact I: Current P: SSR drive voltage V: Voltage
④ Output 2	Y: Contact I: Current P: SSR drive voltage V: Voltage N: None
⑤ Power supply	90: 100-240V AC 10: 24V AC 02: 24V DC
⑥ Event output/ heater break alarm	0:None 1:Event 2:Event + heater break alarm (30A) 3:Event + heater break alarm (50A)
⑦ Remote input	00: None 14: 4-20mA DC 15: 1-5V DC 16: 0-10V DC
⑧ Analog output	0: None 3: 0-10mV DC 4: 4-20mA DC 6: 0-10V DC
⑨ Communi- cation	0: None 5: RS-485 7: RS-232C 8: CC-Link (only for SR83)
⑩ External input (DI)/ set value bias	0:Without 1:With
⑪ Special item	0:Without 1:With

Check the following items attached:

This instruction manual 1 copy
 Unit decal 1 sheet
 Current transformer
 (included in heater break alarm option) 1
 Clamp filter
 (included in communication option for SR82/SR83) 1
 Communication instruction manual
 (Communication option) 1 copy

Note: Contact our representative or sales office for any problems with the product, shortage of the attached components or any other matters requiring clarification.

1-2. Matters requiring attention for use

- (1) Do not use a hard or pointed object in operating the front keys.
They should be operated by touching them lightly with your fingers.
- (2) When you clean the instrument, wipe it lightly with a dry piece of cloth. Solvents such as thinner should not be used.

2. Installation and wiring

2-1. Installation site (environmental conditions)



The instrument should not be installed in those places as listed below. Its use in any of such places may cause trouble or damage or an outbreak of fire:

Contents

page

1. Introduction.....	2
1-1. Check before use	2
1-2. Matters requiring attention for use	2
2. Installation and wiring	2~4
2-1. Installation site (environmental conditions)	2
2-2. Mounting	3
2-3. Drawings showing external dimensions and panel cutout.....	3
2-4. Wiring.....	3
2-5. Terminal arrangement	4
2-6. Terminal arrangement table.....	4
3. Front panel	4~5
3-1. Drawing and names of parts	4
3-2. Description of front panel parts.....	5
4. Screens	5~11
4-1. Power application and initial screen display	5
4-2. Screen configuration.....	5
4-3. Key sequence.....	6~10
4-4. How to move from screen to screen	10
4-5. Data change on each screen.....	10
4-6. Supplementary explanation about screens.....	10
5. Supplementary notes on key operation	11
5-1. AT	11
5-2. Manual adjustment	11
6. Supplement	12~13
6-1. Measuring range list	12
6-2. Event type list	12
6-3. Event standby action.....	12
6-4. Event delay time	12
6-5. 2-output characteristics.....	13
6-6. Error messages.....	13
7. Specifications.....	13~16

- (1) Where flammable gas, corrosive gas, soot, and dust or other particles which can deteriorate insulation are generated or are abundant.
- (2) Where the ambient temperature is below -10°C or above 50°C .
- (3) Where the relative humidity exceeds 90%RH or below the dew point.
- (4) Where highly intense vibration or impact is generated or transferred.
- (5) Near high voltage power lines or where inductive interference is likely to be affected.
- (6) Where dew drops or rays of the sun directly fall.
- (7) Where the elevation is in excess of 2,000 m.

Note: The environmental conditions belong to IEC664 installation category II and the degree of pollution is rated as 2 under this standard.

2-2. Mounting

⚠ CAUTION

For safety's sake and to maintain the proper functioning of the product, you should not draw it out from its case. If it is necessary to draw out the instrument, contact our office in your neighborhood.

- (1) Machine the mounting hole by referring to the panel cutout drawings in Section 2-3.
- (2) Applicable thickness of the mounting panel is from 1.0 to 4.0 mm
- (3) This product is provided with pawls which fix it when it is pressed straight into the front panel.

2-3. Drawings showing external dimensions and panel cutout

(1) SR82

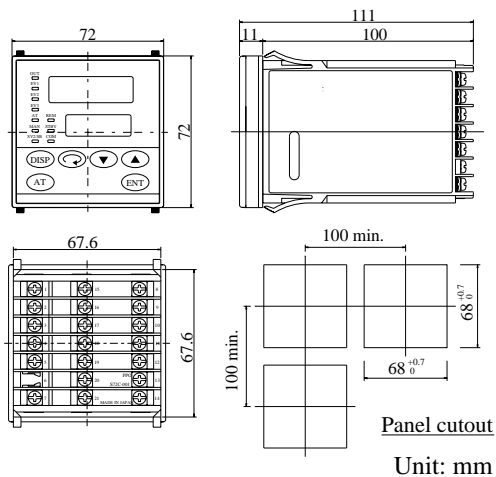

(2) SR83

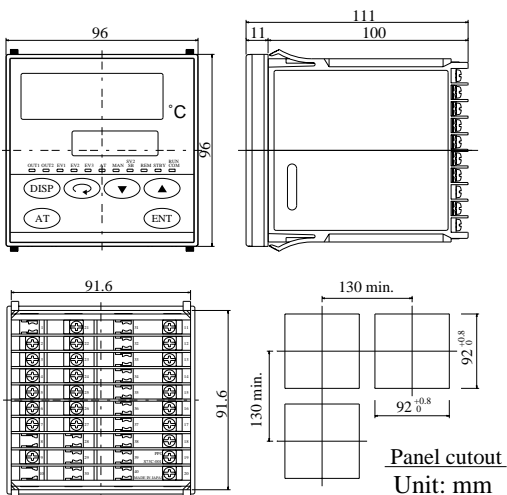

(3) SR84

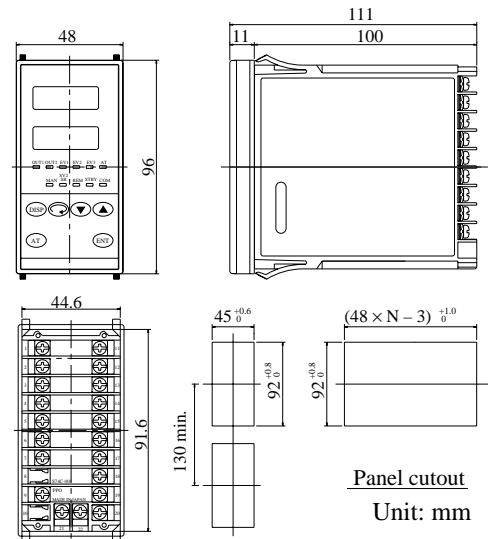

(4) Current transformer (CT) for heater break alarm

For 0-30 A (CTL-6-S)

For 0-50 A (CTL-12-S36-8)

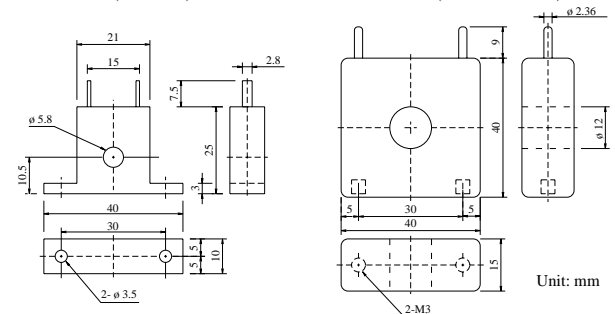

2-4. Wiring

⚠ WARNING

- The product must be disconnected from its power source during wiring operation so as to prevent electric shock.
- The protective conductor (earth) terminal \oplus must be grounded prior to use. Otherwise, electric shock may result.
- Do not touch the wired terminals and charged devices while power is on.

- (1) Wiring should be carried out according to the drawings in "2-5. Terminal arrangement." Confirm that there is no wrong connection.
- (2) Use crimp terminals which meet the M3.5 screw and are less than 7 mm in width.
- (3) For thermocouple input, select a compensation wire suitable for the particular type of thermocouple.
- (4) For R.T.D. input, each lead should be less than 5Ω in resistance and three leads should have the same resistance.
- (5) The input signal line should be conducted safely apart from high voltage power lines.
- (6) Shield wiring (one-point grounding) works effectively against static induction noise.
- (7) Twisting the input signal wire at equal intervals is effective against electromagnetic induction noise.
- (8) For power lines, use wire or cable which is 1 mm^2 in size or thicker and is equivalent to or higher in grade than 600V vinyl insulated wire.
- (9) Earth wiring should be carried out with less than $100\ \Omega$ ground resistance by using wire which is 2 mm^2 or thicker.
- (10) Noise filter: If the instrument appears to be easily affected by power supply noise, use a noise filter for preventing malfunction. The noise filter should be mounted on the grounded panel and make wiring between the controller and the power terminal as short as possible.

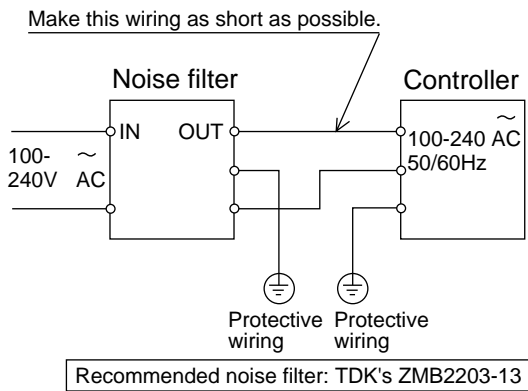

(11) Connection of current transformer (CT):
Pass one load wire through the hole specifically provided for CT. CT terminals on the secondary side are wired to the CT input terminal of the SR80 controller.

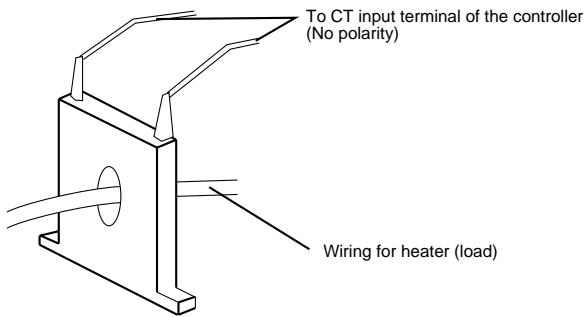

2-5. Terminal arrangement

(1) SR82

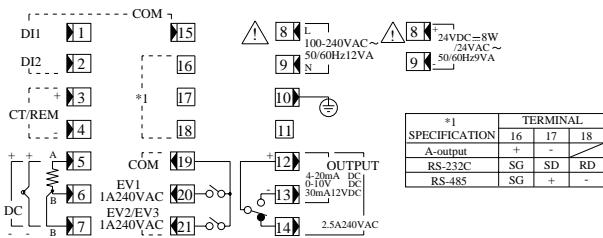

(2) SR83

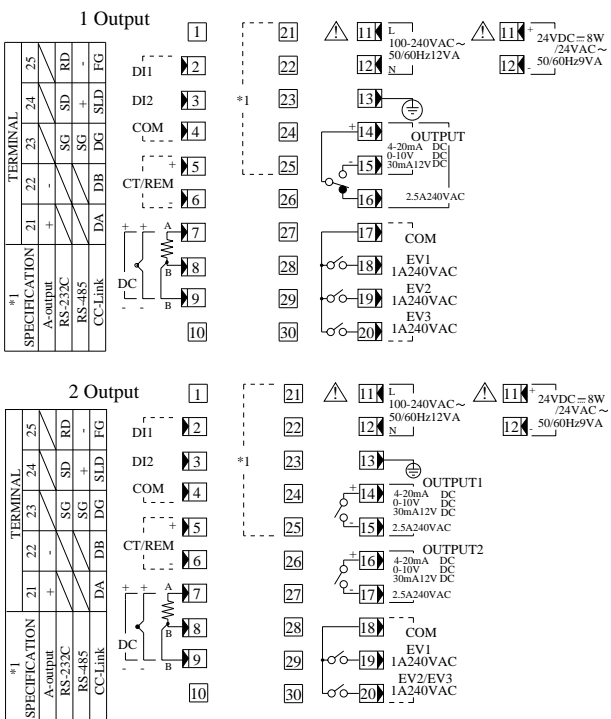

(3) SR84

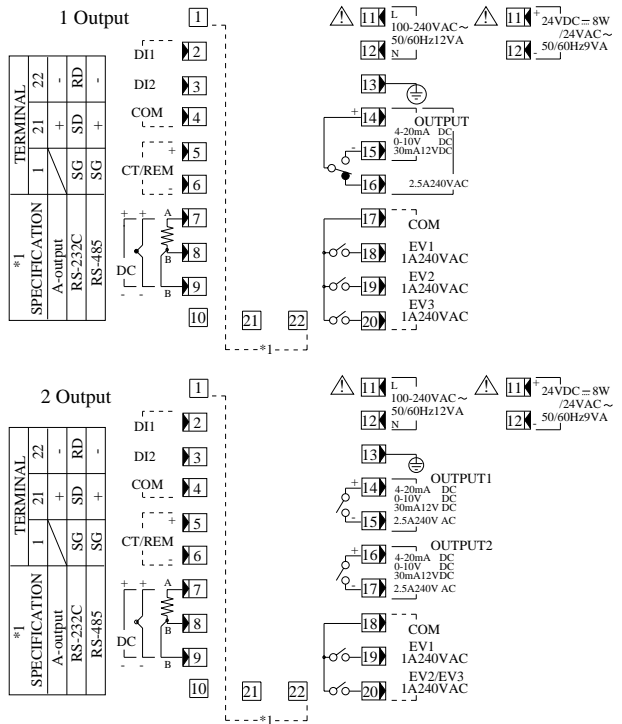

2-6. Terminal arrangement table

Name of terminal and description	SR82	SR83		SR84	
		1 output	2 output	1 output	2 output
Power terminal	100-200V AC 24V AC 24V DC	8-9	11-12	11-12	
Protective conductor terminal	10		13	13	
Input	R.T.D.: A, Thermocouple/voltage/current: + R.T.D.: B R.T.D.: B, Thermocouple/voltage/current: -	5 6 7	7 8 9	7 8 9	
Control output 1	Contact: COM, SSR drive voltage/voltage/current: + Contact: NO, SSR drive voltage/voltage/current: - Contact: NC	12 13 14	14 15 16	14 15 16	14 15 16
Control output 2	Contact: COM, SSR drive voltage/voltage/current: + Contact: NO, SSR drive voltage/voltage/current: - Contact: NC	-	-	16 17	16 17
Event output (option)	Contact: COM Contact: NO (EV1) Contact: NO (EV2) Contact: NO (EV3)	19 20 21	17 18 19 20	17 18 19 20	18 19 20
Remote input (option)	+ -	3 4	5 6	5 6	
Heater break alarm (option)	+ -	3 4	5 6	5 6	
Analog output (option)	+	16 17	21 22	21 22	
Communication (option)	RS-232C: SG SD RD	16 17 18	23 24 25	1 21 22	
External input (DI) (option)	Contact: COM Contact: NO (DI1) Contact: NO (DI2)	15 1 2	4 2 3	4 2 3	





3. Front panel

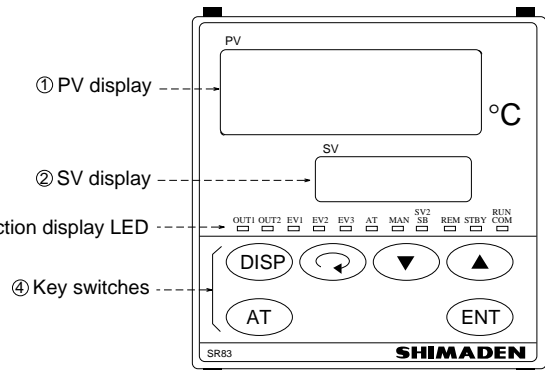



3-1. Drawing and names of parts

As an example, the front panel of SR83 is shown below.



3-2. Description of front panel parts

- ① PV display (red)
 - (1) Displays current measured value (PV) on the mode 0 basic screen.
 - (2) Displays parameter type on each parameter screen.
 - (3) Displays error message when trouble arises in the system.
- ② SV display (green)
 - (1) Displays target set value on the mode 0 basic screen.
 - (2) Displays selected item or set value on each parameter screen.
- ③ Action display LED
 - (1) OUT1 monitor LED (green)
 - For contact or SSR drive voltage output, the LED lights when output turns ON and goes out when output turns OFF.
 - For current or voltage output, the light intensity changes in proportion to the rise and fall of output level.
 - (2) OUT2 monitor LED (green)
 - For contact or SSR drive voltage output, the LED lights when output turns ON and goes out when output turns OFF.
 - For current or voltage output, the light intensity changes in proportion to the rise and fall of output level.
 - (3) EV1 (Event 1) monitor LED (orange)
 - Lights when event 1 is in action.
 - (4) EV2 (Event 2) monitor LED (orange)
 - Lights when event 2 is in action.
 - (5) EV3 (Event 3) monitor LED (orange)
 - Lights when event 3 is in action.
 - (6) AT (Auto Tuning) monitor LED (green)
 - Lights during AT standby and flashes during execution of AT.
 - (7) MAN (Manual) monitor LED (green)
 - Flashes during MAN execution (control output is in manual operation).
 - (8) SV2/SB monitor LED (green)
 - Lights while SV2 is in use.
 - Lights while set value bias is in use.
 - Flashes during ramping execution, goes out when ramping stops if it is for SV1 but lights if it is for SV2.
 - (9) REM (Remote) monitor LED (green)
 - Lights when rEM is selected for remote setting.
 - Flashes in case remote input is below the remote switching set value and local SV is being used.
 - Goes out when Loc is selected for remote setting.
 - (10) STBY (Standby) monitor LED (green)
 - Lights when Stb is selected for STBY setting and goes out when EXE is selected.
 - (11) COM (Communication)/RUN monitor LED (green)
 - Lights when COM is set for communication mode and goes out when LOC is set.
- ④ Key switches
 - (1)  (Disp) key
 - When this key is pressed on any parameter screen, the mode 0 basic screen returns onto the display.
 - (2)  (parameter) key
 - When pressed on any of the mode 0 and 1 screen groups, the next screen appears.
 - When this key is pressed continuously for 3 seconds on the mode 0 basic screen, the direct call screen of the mode 1 screen group appears.
 - (3)  (down) key
 - When pressed on any screen, the decimal point of the least digit flashes and data decreases or the decimal point moves backward.
 - (4)  (up) key
 - When pressed on any screen, the decimal point of the least digit blinks and data increases or the decimal point moves forward.

- (5)  (auto tuning) key
 - Used to prepare for execution/stop of auto tuning action (in mode 0 screen group).
 - Moves screens backward, i.e., in the direction opposite to moves by the  key (in mode 1 screen group).
- (6)  (entry/registration) key
 - Registers data changed by means of  or  key on any of the mode 0, 1 and 2 screen groups. (The decimal point of the least digit goes out.)
 - When pressed continuously for 3 seconds on the 0-1 and 0-2 control output screens, switching between manual and auto of control output is accomplished.

4. Screens

4-1. Power application and initial screen display

Upon applying power, the power-on initial screens shown below come onto display, each for about 1.5 sec. Then the basic screen of the mode 0 screen group is displayed.

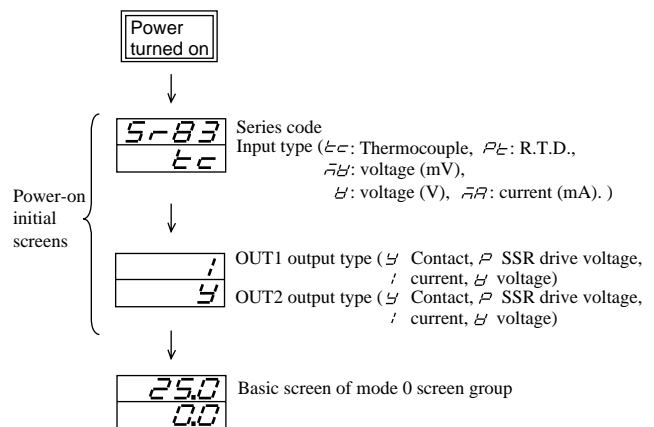

4-2. Screen configuration

In the SR80 series, screens are divided by the frequency of use for the operation of the controller into the following screen groups.



- (1) Mode 0 screen group

The group includes the basic screen (for setting target value and checking current measured value) which is used in relatively high frequency in the operation, PID parameters and the screen for event setting, etc.
- (2) Mode 1 screen group

This group includes setting screens for changing input status and controllability as the occasion demands and screens for locking items intended not to be changed, these screen being less high in frequency of use.

4-3. Key sequence

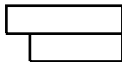
Note 1: Screen frames in 4-2 are as follows.

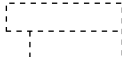
-  Screens always shown by key operation or some other means.
-  Screen displayed or skipped depending on input/output types and control action settings.
-  Screens displayed only when appropriate options are added or selected.

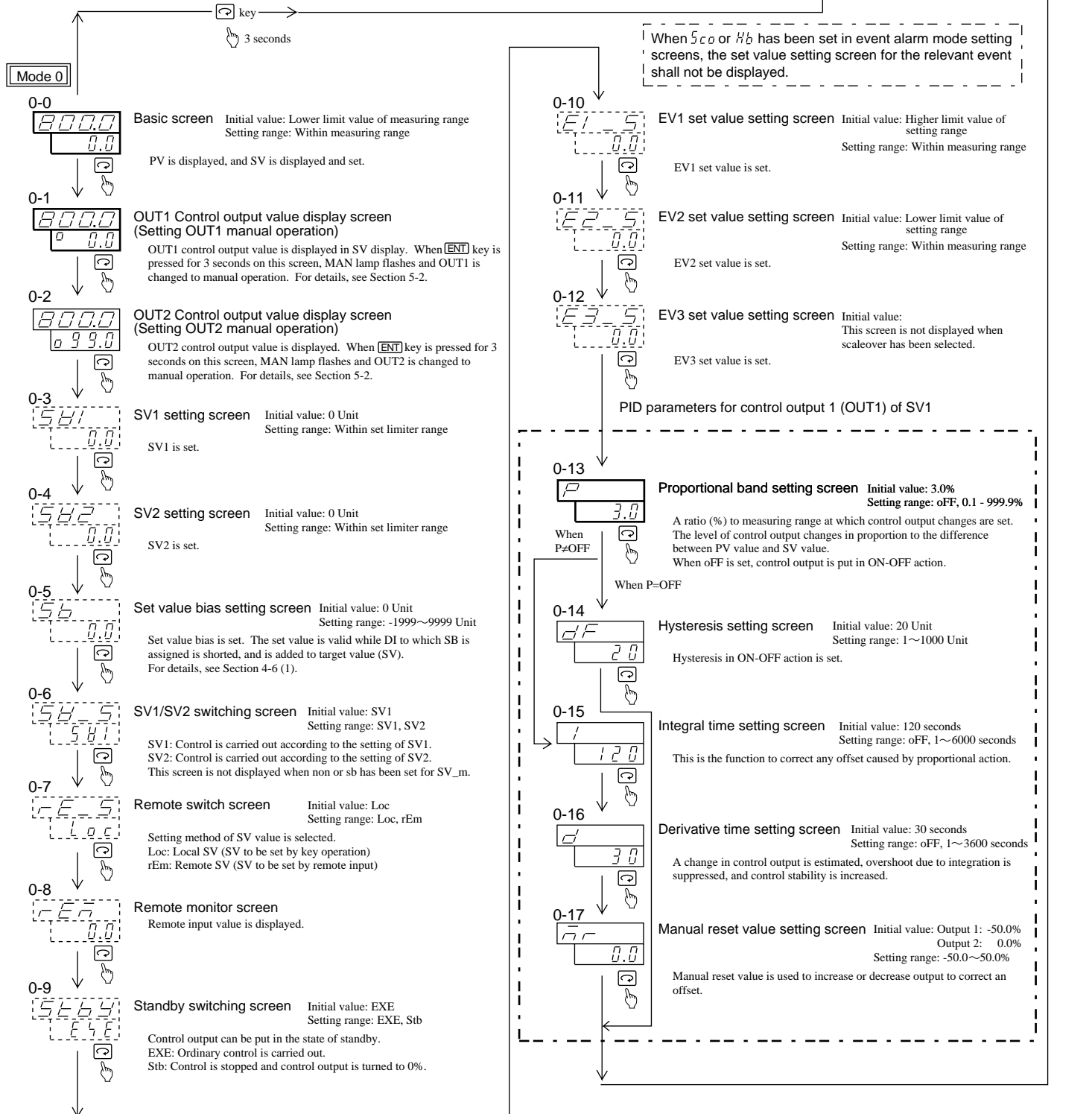

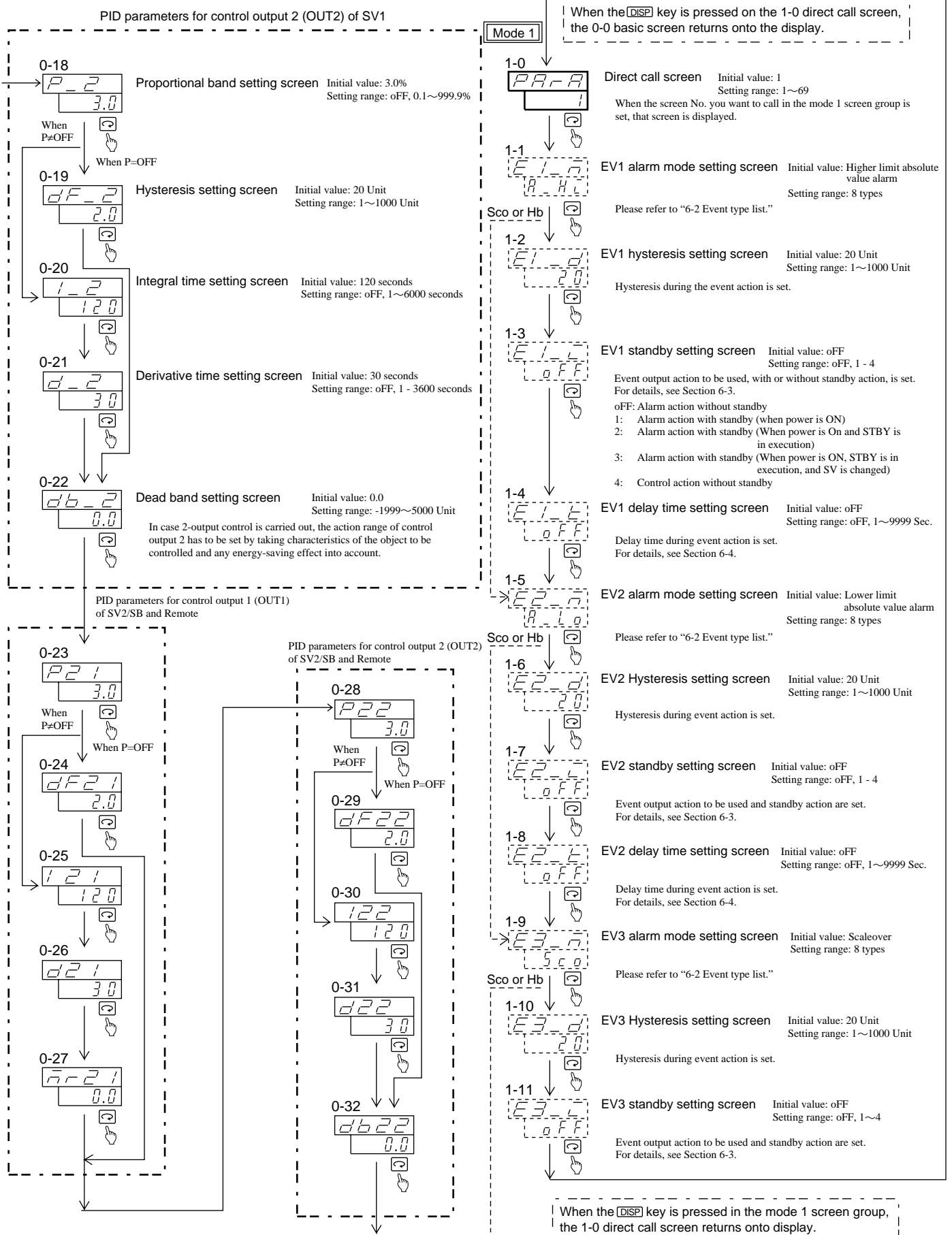

NOTE: Functions, initial values and setting ranges of the 0-25 to 0-32 screens are the same as the other PID parameters.

1-12 EV3 delay time setting screen Initial value: oFF Setting range: oFF, 1~9999 Sec.
 Delay time during event action is set. For details, see Section 6-4.

1-13 Analog output mode setting screen Initial value: PV Setting range: 5 types
 One of the five types shown in the table below is assigned to analog output.

PV [PH]	OUT1 [o1]
SV [SH]	OUT2 [o2]
DEV [dEH]	

1-14 Analog output lower limit scale setting screen Initial value: As per table below Setting range: As per table below
 Lower limit scale of analog output is set. It is conditional that Ao_L≠Ao_H.

MODE	Setting range	Initial value
PV, SV	Within measuring range	Lower limit value of measuring range
DEV	-100.0~100.0%	-100.0%
OUT1, OUT2	0.0~100.0%	0.0%

1-15 Analog output higher limit scale setting screen Initial value: As per table below Setting range: As per table below
 Higher limit scale of analog output is set. It is conditional that Ao_L≠Ao_H.

MODE	Setting range	Initial value
PV, SV	Within measuring range	Higher limit value of measuring range
DEV	-100.0~100.0%	100.0%
OUT1, OUT2	0.0~100.0%	100.0%

1-16 DI1 setting screen Initial value: noP Setting range: 8 types
 Action for DI1 input is set. For details, see Section 4-6(2).

[noP] No processing	Either one of them is displayed according to setting on the 1-52 screen
[SEB] Standby action (level input)	
[- -] When it is not established on the 1-52 screen	
[SH] SV1/SV2 selection (level input)	
[SB] SB action (level input)	
[AT] AT action (edge input)	
[MAN] MAN action (level input)	
[dEH] DA characteristics action (level input)	
[SEB] Ramp temporary stop action (level input)	SB/SV2 selection setting screen
[rEn] REM action (level input)	

1-17 DI2 setting screen Initial value: noP Setting range: 8 types
 Action for DI2 input is set. For details, see Section 4-6(2). For action types to be assigned, refer to those listed above.

1-18 Heater current monitor screen
 Load current detected by CT is displayed for monitoring. In case control output is in ON-OFF action, however, --- is displayed when effective current is not detected.

1-19 Heater break action mode setting screen Initial value: Lock Setting range: Lock, rEAL
 Heater break action mode is set.
 Lock: When an alarm is output, the alarm output is locked, that is, alarm output will continue even when CT current returns to its normal value. Alarm output does not stop unless OFF is set for alarm current value or power is turned OFF.
 rEAL: When an alarm is output, it is released automatically if CT current returns to its normal value.

1-20 Heater break alarm value setting screen Initial value: oFF Setting range: oFF, 0.1~50.0A
 While control output is ON, load line current is detected by CT and if it is smaller than the set current value, it is taken as abnormal and an alarm is output. (Heater break must be assigned to an event.)

1-21 Heater break loop value setting screen Initial value: oFF Setting range: oFF, 0.1~50.0A
 While control output is ON, load line current is detected by CT and if it is larger than the set current value, it is taken as abnormal and an alarm is output. (Heater break must be assigned to an event.)

1-22 Remote bias value setting screen Initial value: 0 Unit Setting range: -1999~1999 Unit
 Remote bias value is set.

1-23 Remote filter setting screen Initial value: oFF Setting range: oFF, 1~100 Sec.
 Remote filter is set.

1-24 Remote switching point setting screen Initial value: oFF Setting range: oFF, 0.1~50.0%.
 Remote switching point is set. For details, see Section 4-6(3).

1-25 Remote switching point Hysteresis setting screen Initial value: 2.0% Setting range: 0.1~10.0%
 Hysteresis at the remote switching point is set.

1-26 Remote lower limit scale setting screen Initial value: Lower limit value of measuring range Setting range: Within measuring range.
 Remote lower limit scale value is set. It is conditional that rE_L≠rE_H.

1-27 Remote higher limit scale setting screen Initial value: Higher limit value of measuring range Setting range: Within measuring range.
 Remote higher limit scale value is set. It is conditional that rE_L≠rE_H.

1-28 Remote tracking setting screen Initial value: no Setting range: no, yES
 Remote SV value can be transferred to local SV value.
 yES: Upon switching from remote SV to local SV, remote SV is copied in local SV.
 no: Remote tracking does not function.
 For details, please refer to the communication interface instruction manual.

1-29 Communication mode selection screen Initial value: LOC Setting range: COM→LOC
 Communication mode is selected.
 LOC mode: Only read commands by communication are valid.
 COM mode: Read and write commands by communication are valid.
 Only changing COM to LOC is possible by front key operation.

1-30 Communication address setting screen Initial value: 1 Setting range: 1~99
 Machine Number(s) is set when a plurality of instruments are connected for communication.

1-31 Communication speed setting screen Initial value: 1200 bps Setting range: 1200, 2400, 4800, 9600, 19200 bps
 A speed at which data is transmitted to host computer is set.

1-32 Communication data format setting screen Initial value: 7E1 Setting range: 7E1, 7E2, 7N1, 7N2, 8E1, 8E2, 8N1, 8N2
 Communication data format is set.

1-33 Communication control code setting screen Initial value: 1 Setting range: 1~31
 Communication control code is set.
 1:STX_ETX_CR 2:STX_ETX_CRLF 3:@:_CR

1-34 Communication BCC check setting screen Initial value: 1 Setting range: 1~4
 Operating method to be used in BCC check is set.
 1: ADD 2: ADD_two's cmp 3: XOR 4: None

1-35 Communication memory mode setting screen Initial value: EEP Setting range: EEP, Ram, r_E
 EEP: Data is written into EEPROM.
 Ram: Data is written into RAM.
 r_E: Data is written in EEPROM. (SV and OUT are written into RAM.)

1-36 Communication delay time setting screen
Initial value: 20
Setting range: oFF, 1~100
Delay time from receipt of communication command to transmission is set.

1-37 Output characteristics setting screen
Initial value: rA
Setting range: rA, dA
Control characteristics of control output is set.
For 2-output characteristics, see Section 6-5.
rA: The more PV value is in excess of SV value, the lower the output (heating control).
dA: The more PV value is in excess of SV value, the higher the output (cooling control).

1-38 Control output 1 proportional cycle setting screen
Initial value: contact output 30 sec, SSR drive voltage 3 sec.
Setting range: 1~120 Sec.
Proportional cycle time of control output 1 is set.

1-39 Control output 2 proportional cycle setting screen
Initial value: contact output 30 sec, SSR drive voltage 3 sec.
Setting range: 1~120 Sec.
Proportional cycle time of control output 2 is set.

1-40 SV1 control output 1 lower limit output limiter setting screen
Initial value: 0.0%
Setting range: 0.0~99.9% on condition that o_L<o_H.
Lower limit output limiter of SV1 control output 1 is set.

1-41 SV1 control output 1 higher limit output limiter setting screen
Initial value: 100.0%
Setting range: 0.1~100.0% on condition that o_L<o_H.
Higher limit output limiter of SV1 control output 1 is set.

1-42 SV1 control output 2 lower limit output limiter setting screen
Initial value: 0.0%
Setting range: 0.0~99.9% on condition that o_2L<o_2H.
Lower limit output limiter of SV1 control output 2 is set.

1-43 SV1 control output 2 higher limit output limiter setting screen
Initial value: 100.0%
Setting range: 0.1~100.0% on condition that o_2L<o_2H.
Higher limit output limiter of SV1 control output 2 is set.

1-44 SV2, SB/REM control output 1 lower limit output limiter setting screen
Initial value: 0.0%
Setting range: 0.0~99.9% on condition of o21L<o21H.
Lower limit output limiter of SV2 control output 1 is set.

1-45 SV2, SB/REM control output 1 higher limit output limiter setting screen
Initial value: 100.0%
Setting range: 0.1~100.0% on condition that o21L<o21H.
Higher limit output limiter of SV2 control output 1 is set.

1-46 SV2, SB/REM control output 2 lower limit output limiter setting screen
Initial value: 0.0%
Setting range: 0.0~99.9% on condition that o22L<o22H.
Lower limit output limiter of SV2 control output 2 is set.

1-47 SV2, SB/REM control output 2 higher limit output limiter setting screen
Initial value: 100.0%
Setting range: 0.1~100.0% on condition that o22L<o22H.
Higher limit output limiter of SV2 control output 2 is set.

1-48 Control output 1 error output setting screen
Initial value: 0.0%
Setting range: 0.0~100.0%
Control output 1 in the case of scaleover of measured input value is set.

1-49 Control output 2 error output setting screen
Initial value: 0.0%
Setting range: 0.0~100.0%
Control output 2 in the case of scaleover of measured input value is set.

1-50 PV bias setting screen
Initial value: 0 Unit
Setting range: -1999~1999 Unit
This is used to correct an error of input from sensor, etc.
When bias is applied, control, too, is carried out with the corrected value.

1-51 PV filter setting screen
Initial value: oFF
Setting range: oFF, 1~100 Sec.
PV filter is set.

1-52 SB/SV2 selection setting screen
Initial value: non
Setting range: non, SV, Sb
Which of SB and SV2 functions is to be used is selected and set.
non: Neither SV2 function nor SB function can be used.
SV: SV2 function can be used.
Sb: SB function (set value bias) can be used.

1-53 SV set value lower limit limiter setting screen
Initial value: Lower limit value of measuring range
Setting range: Within measuring range
Lower limit limiter of SV set value is set, but it is necessary that SV_L<SV_H.

1-54 SV set value higher limit limiter setting screen
Initial value: higher limit value of measuring range
Setting range: Within measuring range
Higher limit limiter of SV set value is set, but it is necessary that SV_L<SV_H.

1-55 Ramp ascending value setting screen
Initial value: oFF
Setting range: oFF, 1~9999 Unit
Upon switching between SV and SV2 or SB switching, it is feared to cause an abrupt change in load. By setting an amount of change (value of ascent), target value changes gradually.

1-56 Ramp descending value setting screen
Initial value: oFF
Setting range: oFF, 1~9999 Unit
Upon switching between SV and SV2 or SB switching, it is feared to cause an abrupt change in load. By setting an amount of change (value of descent), target value changes gradually.

1-57 Ramp unit setting screen
Initial value: SEc
Setting range: SEc, min
The unit of ramp value is set.

1-58 Ramp multiplier setting screen
Initial value: × 1
Setting range: × 1, × 0.1
A multiplier for ramp is set.
4.1: × 1 4.0: × 0.1

1-59 AT point setting screen
Initial value: 0 Unit
Setting range: 0~5000 Unit
AT point is set. For details, see Section 4-6 (4).

1-60 SV1 control output 1 target value function setting screen
Initial value: 0.40
Setting range: 0.00~1.00
This is used for correction if overshoot or undershoot from set value arises during execution of PID control.

1-61 SV1 control output 2 target value function setting screen
Initial value: 0.40
Setting range: 0.00~1.00
This is used for correction if overshoot or undershoot from set value arises during execution of PID control.

1-62 SV2, SB/REM control output 1 target value function setting screen
Initial value: 0.40
Setting range: 0.00~1.00
This is used for correction if overshoot or undershoot from set value arises during execution of PID control.

1-63 SV2, SB/REM control output 2 target value function setting screen
Initial value: 0.40
Setting range: 0.00~1.00
This is used for correction if overshoot or undershoot from set value arises during execution of PID control.

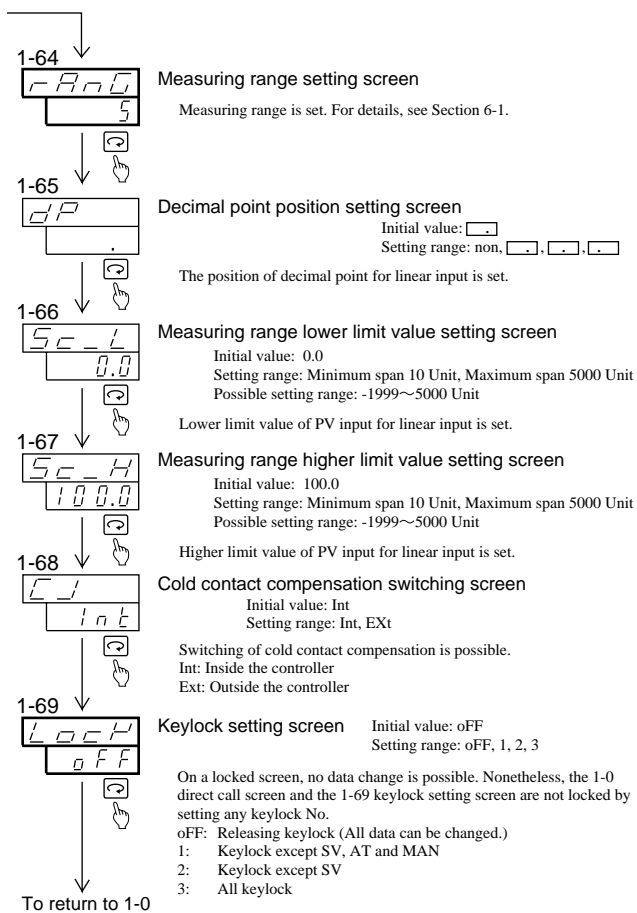

4-4. How to move from screen to screen

(1) Moving between mode 0 screen group and mode 1 screen group

- Pressing the key continuously for 3 seconds on the basic screen of the mode 0 screen group brings the direct call screen of the mode 1 screen group onto display. Pressing the key on any screen of the mode 1 screen group, the display returns to the basic screen of the mode 0 screen group.

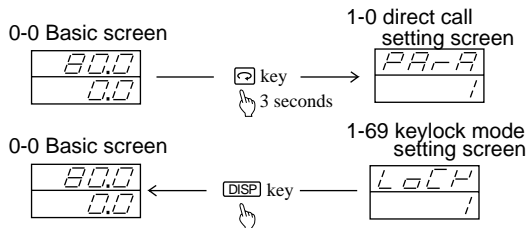

NOTE: The mark shown above means pressing the key above the mark. This applies to all the subsequent drawings.

(2) Moving from screen to screen in the mode 0 screen group

- The next screen appears every time the key is pressed.



(3) Moving from screen to screen in the mode 1 screen group

- There are three methods of moving from screen to screen in the mode 1 screen group as shown below:
 - To press the key in the same way as in the mode 0 screen group. (See (2) above.)
 - To enter the number of a screen you want to call on the 1-0 direct call screen.

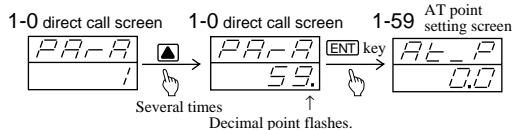

iii) The preceding screen appears every time the key is pressed. (This function of AT key works only in the mode 1 screen group.)

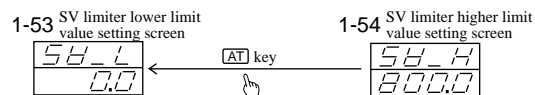

4-5. Data change on each screen

To change data on each screen, press the or key. Changed data should be registered by pressing the key. Once the data is registered, the decimal point on the bottom right stops flashing and goes out.

4-6. Supplementary explanation about screens

(1) 0-5 set value bias setting screen

By setting a bias value for a target set value beforehand, the original target set value added with the bias value becomes the new target value when the DI assigned for SB turns ON (shorted).

DI ON = Target set value (SV) + bias value (SB)

DI OFF = Target set value (SV)

NOTE: To use the set value bias function, you have to assign SB to a DI and set SB for SV mode.

(2) 1-16 DI1 setting screen and 1-17 DI2 setting screen

- If you select [5B], SV2 takes effect when DI input turns ON.
- When to detect external control input signal:
Level input: The action is maintained as long as the contact remains ON.
Edge input: The action is maintained even when the contact is turned OFF after it has been in action for 0.3 seconds or longer. If the contact remains ON for 0.3 seconds subsequently, the action is released.
- If an action of the same type is assigned to DI1 and DI2, the assignment to DI2 becomes void.
- An action assigned to a DI cannot be controlled by key operation. (priority is given to DI input.)
- An action through DI input is held even after release of the DI assignment.

(3) 1-24 remote switching point setting screen

Setting a remote switching point on this screen allows local SV to be switched to remote SV at the time when remote input reaches the desired value (%).

- When OFF is set for remote switching point → Conventional remote switching action → By switching to remote on the remote switching setting screen (rEm) of the user setting screen group, local is immediately switched to remote and the remote lamp lights.
- When a value, i.e., not “oFF”, is set for remote switching point → remote switching action according to applied voltage or current. In case the value of voltage or current input remotely upon switching to remote on the remote switching setting screen (rEm) exceeds the set value (%) of remote switching point, SV is switched to remote and remote lamp lights. If remote input falls below the set value (%) of remote switching point, it switches to local SV and the remote lamp flashes.

Note: There is no remote switching while AT is in execution.

Note: If the remote input at the time when remote switching is set on the remote switching setting screen (rEm) is below the set value (%) of remote switching point, the remote lamp flashes and it is switched to local SV.

(4) 1-59 AT execution point setting screen

For the purpose of avoiding hunting due to a limit cycle with a set SV AT execution, a virtual SV value (AT execution point) is set for AT to run at a point away from the actual SV value.

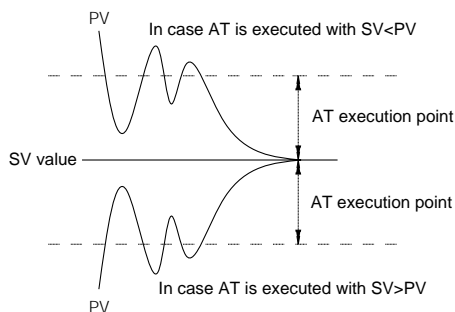

Note 1: For AT execution point, an absolute value of difference between SV value and virtual SV value is to be input.

Note 2: When 0 is set for AT execution point, SV value serves as the AT point.

Note 3: When PV value is in the AT execution point area, SV value serves as the AT point.

5. Supplementary notes on key operation

5-1. AT

When AT is executed, PID constants are calculated and defined from repeated ON/OFF action (100%/0%) output for the measuring value increase and decrease around the set value and are stored in the internal memory to complete operation. Upon completion, control using stored PID constants begins.

How to execute AT

1. Press the **[AT]** key in the mode 0 screen group. Auto tuning is brought to the state of standby. (AT lamp lights.)
2. Press the **[ENT]** key to register. Auto tuning is executed. (AT lamp flashes.)

Note: AT can be executed even with remote SV. (The remote SV at the time when AT execution point is set is used in the execution.)

Note: AT cannot be executed in the mode 1 screen group.

- AT is not executed in the following conditions (When the **[ENT]** key is pressed, the AT lamp goes out.)
 1. During ramp control
 2. During manual operation
 3. In the state of STANBY
 4. "oFF" setting for proportional band (ON/OFF action)
 5. Selection of 2 or 3 on the keylock mode setting screen
 6. Scaleover of PV value (measured value)

Cancellation of AT

AT can be cancelled in mid-operation by pressing the **[AT]** key again. Press the **[ENT]** key for confirmation. The AT lamp goes out.

Note: When AT is cancelled in the mid-operation, PID values remain unchanged.

- AT is automatically cancelled under the following conditions:
 1. Output value remains at 0% or 100% for two or more hours.
 2. Power supply is interrupted due to power failure or for other reason.
 3. Scaleover of PV (measured value) during AT execution.
 4. STNDBY is executed.

5-2. Manual adjustment

On the 0-1 OUT1 control output value display screen and 0-2 OUT2 control output value display screen, it is possible to change

to the control output manual mode and to set a manual control output value.

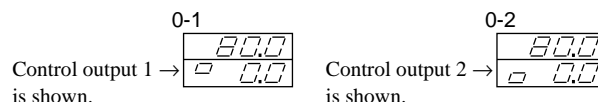

Change to manual control mode

On a display screen of control output intended to be changed (0-1 or 0-2), press the **[ENT]** key for 3 seconds continuously. The MAN lamp flashes and it is changed to the manual mode to allow you to set a control output value by means of the **[▲]** or **[▼]** key. Likewise, the manual control output mode is switched to the ordinary automatic mode by continuously switching the **[ENT]** key for 3 seconds. Then the MAN lamp goes out.

- Rules applied to manual control

1. Manual control action and output value are kept in memory even when power is turned OFF and is reapplied.
2. When the measuring range is changed, the manual control mode is cancelled and replaced by automatic control mode.
3. Upon switching auto to manual, balanceless and bumpless control is carried out. If the measured value is out of the proportional band at the time of mode switching, however, balanceless and bumpless control is not performed.
4. The control output range in the manual control mode is within a range defined by output limiter. (When P=OFF or during ON/OFF action, control is carried out with lower limit **[▼]**: 0.0% and higher limit **[▲]**: 100.0%. Nevertheless, 100% output is displayed as follows on account of limited display space.

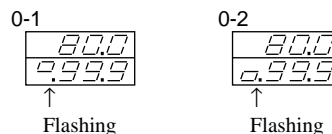

6. Supplement

6-1. Measuring range list

Input type	Code	Measuring range	Code	Measuring range
Thermocouple	*1 B	01 0 ~ 1800 °C	15	0 ~ 3300 °F
	R	02 0 ~ 1700 °C	16	0 ~ 3100 °F
	S	03 0 ~ 1700 °C	17	0 ~ 3100 °F
	K1	04 -100.0 ~ 400.0 °C	18	-150 ~ 750 °F
	K2	05 0.0 ~ 800.0 °C	19	0 ~ 1500 °F
	K3	06 -200 ~ 1200 °C	20	-300 ~ 2200 °F
	E	07 0 ~ 700 °C	21	0 ~ 1300 °F
	J	08 0 ~ 600 °C	22	0 ~ 1100 °F
	T	09 -199.9 ~ 200.0 °C	23	-300 ~ 400 °F
	N	10 0 ~ 1300 °C	24	0 ~ 2300 °F
	PLII	11 0 ~ 1300 °C	25	0 ~ 2300 °F
	WRe5-26	12 0 ~ 2300 °C	26	0 ~ 4200 °F
	U	13 -199.9 ~ 200.0 °C	27	-300 ~ 400 °F
	L	14 0 ~ 600 °C	28	0 ~ 1100 °F
	K		29	10.0 ~ 350.0 K
	AuFe-Cr		30	0.0 ~ 350.0 K
K		31	10 ~ 350 K	
AuFe-Cr		32	0 ~ 350 K	
R.T.D.		01 -200 ~ 600 °C	17	-300 ~ 1100 °F
		02 -100.0 ~ 100.0 °C	18	-150.0 ~ 200.0 °F
	Pt100 (New) JIS/IEC	03 -100.0 ~ 300.0 °C	19	-150 ~ 600 °F
		04 -50.0 ~ 50.0 °C	20	-50.0 ~ 120.0 °F
		05 0.00 ~ 50.00 °C	21	0.0 ~ 120.0 °F
		06 0.0 ~ 100.0 °C	22	0.0 ~ 200.0 °F
		07 0.0 ~ 200.0 °C	23	0.0 ~ 400.0 °F
		08 0.0 ~ 500.0 °C	24	0 ~ 1000 °F
		09 -200 ~ 500 °C	25	-300 ~ 1000 °F
		10 -100.0 ~ 100.0 °C	26	-150.0 ~ 200.0 °F
	JPt100 (Old) JIS	11 -100.0 ~ 300.0 °C	27	-150 ~ 600 °F
		12 -50.0 ~ 50.0 °C	28	-50.0 ~ 120.0 °F
		13 0.00 ~ 50.00 °C	29	0.0 ~ 120.0 °F
		14 0.0 ~ 100.0 °C	30	0.0 ~ 200.0 °F
		15 0.0 ~ 200.0 °C	31	0.0 ~ 400.0 °F
		16 0.0 ~ 500.0 °C	32	0 ~ 1000 °F
mV	-10 ~ 10	01	The scaling function allows you to select any value within the following ranges: Scaling range: -1999~9999 count Span: 10~5000 count but lower limit side<higher limit side *1 Thermocouple B: 400 °C and 750 °F or below is not covered by accuracy guarantee.	
	0 ~ 10	02		
	0 ~ 20	03		
	0 ~ 50	04		
	10 ~ 50	05		
	0 ~ 100	06		
V	-1 ~ 1	01		
	0 ~ 1	02		
	0 ~ 2	03		
	0 ~ 5	04		
	1 ~ 5	05		
	0 ~ 10	06		
mA	0 ~ 20	01		
	4 ~ 20	02		

Note: The following codes represent the respective factory-set measuring ranges.

Input	Standard/rating	Code	Measuring range
Thermocouple	JIS K	05	0.0~800.0 °C
R.T.D.	JIS Pt100	07	0.0~200.0 °C
Voltage(mV)	0~10mV DC	02	0.0~100.0
Voltage(V)	1~5V DC	05	0.0~100.0
Current (mA)	4~20mA DC	02	0.0~100.0

NOTE: If you change a measuring range code, all measuring ranges related to data such as SV value, event set values, PID are initialized.

NOTE: When a type code of event, remote input or analog output is changed, all data related to it are initialized.

6-2. Event type list

Event type code	Event type	Setting range of event set value	Initial value of event set value
① $A-H$	Higher limit absolute value	Within measuring range	Higher limit value of measuring range
② $A-L$	Lower limit absolute value	Within measuring range	Lower limit value of measuring range
③ $d-H$	Higher limit deviation value	-1999 ~ 9999 Unit	2000 Unit
④ $d-L$	Lower limit deviation value	-1999 ~ 9999 Unit	-1999 Unit
⑤ $d-o$	Out of higher and lower limit ranges	0 ~ 9999 Unit	2000 Unit
⑥ $d-c$	Within higher and lower limit ranges	0 ~ 9999 Unit	2000 Unit
⑦ Sco	Scaleover	EV output continues when scaleover occurs.	
⑧ Hb	Heater break	Event output continues when heater break alarm is output.	

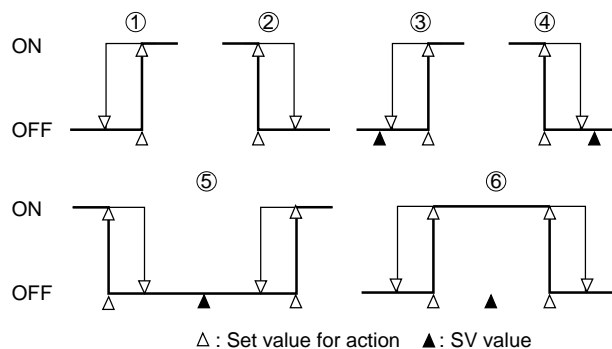

Δ : Set value for action ▲ : SV value

NOTE: Code ⑧ in the above table can be selected and set only when the instrument includes the heater break alarm option.

6-3. Event standby action

- In case an event output is used as an alarm, set "oFF," "1," "2," or "3."
- In case an event output is used as control output, set "4."
- If scaleover occurs on the event set value side, however, event output remains OFF during standby.
- When "1" has been set for event action, the standby action functions when:
 - power is applied.
- When "2" has been set for standby action, the standby action functions when:
 - power is applied;
 - STBY → EXE;
- When "3" has been set for standby action, the standby action functions when:
 - power is applied;
 - STBY → EXE;
 - SV is changed where standby set value is a deviation value. (Except during remote input, though.)
- When the standby action setting is changed to "oFF" or "4" while standby is in action, the standby action is cancelled immediately.
- If, upon applying power, PV value is out of the range in which event action is ON, standby action becomes void even when "1," "2," or "3" has been set for it.

6-4. Event delay time

- If a factor which has turned event action ON disappears, the event will not be output and delay time measurement is aborted.
- If a factor to turn event action ON arises and delay time is changed within the setting range of delay time, the time starting from the occurrence of the factor to activate the event (i.e., a total time) works as the delay time.

6-5. 2-output characteristics

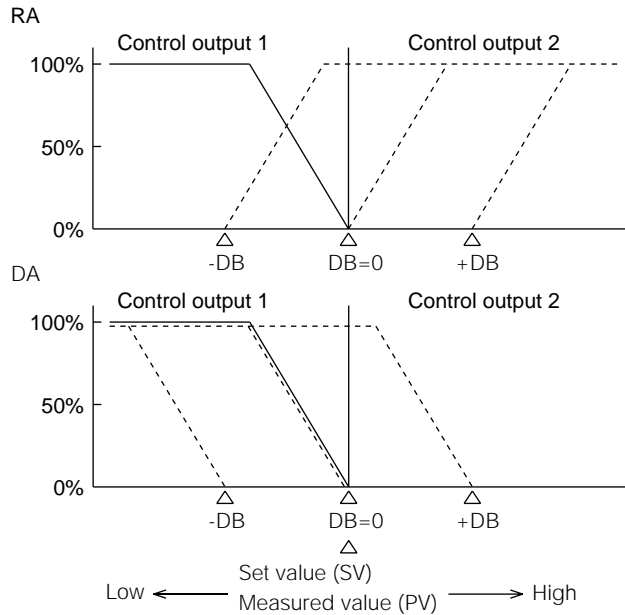

6-6. Error messages

If a problem arises in the controller, one of the following error messages will be displayed on the screen.

(1) Problems with measured input (shown on PV display)

5cHH Indicates thermocouple break, R.T.D.A break, or PV value being about 10% on the high side of higher limit of measuring range.

5cLL Indicates PV value being about 10% on the low side of lower limit of measuring range due to inverse polarity of input wiring.

5JHH Indicates that Reference contact (CJ) defects to higher side for thermocouple input.

5JLL Indicates that Reference contact (CJ) defects to lower side for thermocouple input.

b--- Indicates break of B (middle) or multiple break of A.B.B. for R.T.D. input.

c--- Indicates break of B (bottom) for R.T.D. input.

(2) Problems with remote input (shown on SV display)

rEHH Indicates that remote input value has exceeded higher limit of remote scale (+110%FS).

rELL Indicates that remote input value has fallen below lower limit of remote scale (-10%FS).

(3) Problems with heater break alarm (shown on SV display)

HbHH Indicates that CT input value has exceeded 55A.

HbLL (Indicates that CT input value has fallen below -5A.)

NOTE: If a problem arises and its cause appears to lay inside the instrument, please call our representative or sales office.

7. Specifications

■DISPLAY

- LED display: Measured value (PV) display/
7-segment red LED 4 digits
Set value (SV) display/
7-segment green LED 4 digits
 $\pm (0.25\% \text{ FS} + 1 \text{ digit})$
- Display accuracy: $23^\circ\text{C} \pm 5^\circ\text{C}$
- Range in which display accuracy is maintained: $23^\circ\text{C} \pm 5^\circ\text{C}$
- Display resolution: Depends on measuring range
(0.001, 0.01, 0.1, 1)
- Sampling cycle: 250 msec. (0.25 sec.)
- Action display/color: 11 types, LED lamp display
- Control output: (OUT1, 2)/
green
- Event action (EV1, 2, 3)/
orange
- Auto tuning action (AT)/green
- Manual control action (MAN)/green
- Set value bias action (SV2/SB)/green
- Remote action (REM)/green
- Standby action (STBY)/green
- Communication status (COM/RUN)/
green

■SETTING

- Setting method: By front key switch operation
- Setting range: Same as measuring range
(within setting limiter)
- Setting limiter: Higher and lower limits separate
setting; free within measuring range
(Lower limit < higher limit)
- Set value resolution: Depends on range and scaling
(0.001, 0.01, 0.1, 1)
- Setting key type: 6 types - PARA (parameter selection),
UP, DOWN, AT, ENT and DISP keys
- Ramp control upon reaching set value: Ascending/descending ramp control
- Ramp setting range: OFF, 1~9999 Units
- Ramp unit time: /sec, /min switching by front key
operation and communication
- Ramp rate: $\times 1, \times 0.1$ switching by front key
operation and communication

■INPUT

- Thermocouple: B, R, S, K, E, J, T, N, PL II, WRe5-
26, {L, U (DIN43710)}K, AuFe-Cr
Kelvin unit input
- Allowable external resistance range: 100 Ω maximum
- Input impedance: 500k Ω minimum
- Burnout function: Standard feature (up scale)
- Cold junction temperature compensation accuracy: $\pm 2^\circ\text{C}$ (within a range from 5 to 45°C)
- R.T.D.: Pt100/JPt100
- Amperage: About 0.25 mA
- Allowable range of lead wire resistance: 5 Ω maximum/wire
- Voltage (multiple input): -10~10, 0~10, 0~20, 0~50, 10~50,
0~100mV DC, or -1~1, 0~1, 0~2,
0~5, 1~5, 0~10V DC
- Input impedance: 500k Ω minimum
- Current: 0~20mA, 4~20mA DC
- Receiving impedance: 250 Ω
- Sampling cycle: 250 msec. (0.25 sec.)
- PV bias: -1999~1999 Units
- PV filter: OFF, 1~100 sec.
- Reference contact compensation switching: INT (internal)/EXT (external)
switching by front key operation

Isolation:	Insulated from various outputs (not insulated from system, DI (external switching input) and CT input)	load current 30mA maximum Current (I): 4~20mA DC, load resistance 600Ω maximum. Voltage (V): 0~10V DC, load current 2mA maximum	
■CONTROL (SR82: 1 output only)			
• Control system:	One output operation: Expert PID control with auto tuning function RA (reverse characteristics): Heating action DA (due characteristics): Cooling action Two output operation (option): Expert PID + PID (control outputs 1 and 2 individually in action) control with auto tuning function RA (reverse characteristics): Heating action (output 1 side and cooling (output 2 side) DA (due characteristics): 2-stage heating action (by both of control outputs 1 and 2)	• Output resolution Control output 1: About 0.0125% (1/8000) Control output 2: About 0.5% (1/200) • Sampling cycle: 250 msec. (0.25 sec.) • Manual control Manual switching: Front key operation or DI (external switching input) through communication Manual control output: 0.0-100.0% (out of output limiter range possible) Setting resolution: 0.1% Manual←→automatic control: Balanceless bumpless (within proportional band, though)	
• PID (Control outputs 1 and 2 individually) Control output 1:	Proportional band (P):OFF, 0.1~999.9% (OFF=ON/OFF action) Integral time (I): OFF, 1~6000 sec. (OFF= with manual reset) Derivative time (D): OFF, 0~3600 sec. Manual reset: -50.0 to +50.0% (valid when I=OFF) ON/OFF hysteresis: 1~1000 unit (valid during ON/OFF action)	• Isolation: Insulated between control output and system and various inputs (not insulated between control output of current, voltage or SSR and analog output)	
Control output 2 (only when two output option is added):	Proportional band (P): OFF, 0.1~999.9% (OFF=ON/OFF action) Integral time (I): OFF, 1~6000 sec. Derivative time (D): OFF, 0~3600 sec. ON/OFF hysteresis: 1~1000 Units (valid during ON/OFF action) Dead band: -1999~5000 Units Separate setting for SB/SV2 is possible. Setting range is the same as the one listed above.	■EVENT OUTPUT (optional)	
• Proportional cycle:	(for contact and SSR drive voltage output)	• Number of event outputs:	SR82 - 2 SR83 - 3 (2 when 2 output option is added) SR84 - 3 (2 when communication option, analog output option and/or 2 output option are added) (In case of 2 event outputs, EV2 and EV3 are common output with OR.)
Control output 1: Control output 2:	1~120 sec. 1~120 sec.	• Event type:	Selectable from 8 types (7 types when heater break alarm option is not added) A_Hi: Higher limit absolute value alarm A_Lo: Lower limit absolute value alarm D_Hi: Higher limit deviation value alarm D_Lo: Lower limit deviation value alarm D_i: Higher/lower limit deviation value alarm (within range) D_o: Higher/lower limit deviation value alarm (out of range) Sco: Scaleover (input trouble alarm) Hb: Heater break alarm (selectable only when heater break alarm option is added)
• AT point setting:	0-5000 Units	• Event setting range	Deviation value alarm Higher limit alarm: -1999~9999 Units Lower limit alarm: -1999~9999 Units Higher/lower limit alarm: 0~9999 Units Absolute value alarm Both higher and lower limits: Within measuring range
• Control output characteristics:	RA (reverse characteristics)/DA (due characteristics) switchable by front key operation or DI (external switching input) through communication.	Event setting system:	By front key operation
• Higher and lower limit output limiter (individually for control outputs 1 and 2):	Lower limit side: 0.0~99.9%, Higher limit side: 0.1~100.0% on condition that lower limit value < higher limit value. Separate setting for SB/SV2 is possible. Setting range is the same as the one listed above.	• Event action:	ON/OFF action
• Control output at time of error (individually for control outputs 1 and 2) :	0.0~100.0%	• Event hysteresis:	1~1000 Units
• Control output type/rating (common to control outputs 1 and 2):	Contact (Y): 240V AC 2.5A/resistive load SSR drive voltage (P): 12V±1.5V DC,	• Standby/no standby action:	Selectable from 5 types Alarm action without standby Alarm action with standby (When power is ON) Alarm action with standby (When power is ON, when standby is switched to execution)

- Alarm action with standby (When power is ON, when standby is switched to execution, including the time when SV is changed)
Control action
 - Event action delay: OFF, 1~9999 sec.
 - Event output/rating: Contact 240V AC 1.0A (resistive load)
 - Output updating cycle: 250 msec. (0.25 sec.)
- ANALOG OUTPUT (optional, not selectable together with communication type (1) and (2))
- The number of analog output: 1
 - Output signal: Selectable from 5 types (3 types for instrument with one output)
 PV: Measured value
 SV: Set value
 DEV: Bias output
 OUT 1: Control output 1
 OUT 2: Control output 2 (selectable only when 2 output option is added)
 - Output type/rating: 0~10 mV DC/FS Output impedance: 10Ω
 0~10 V DC/FS Load current: 2mA maximum
 4~20mA DC/FS Load resistance: 300Ω maximum
 - Output scaling: PV/SV: Within measuring range (inverted scaling possible)
 OUT1/OUT2: 0.0-100.0% (inverted scaling possible)
 DEV: -100.0~100.0% (inverted scaling possible) on condition that $Ao_L \neq Ao_H$
 - Output accuracy: $\pm 0.25\%$ FS (to displayed value)
 - Output resolution: 0.01% FS (1/10000)
 - Output updating cycle: 250 msec. (0.25 sec.)
 - Isolation: Insulated from system and various inputs (not insulated from control outputs I, P and V)

■HEATER BREAK ALARM (optional, not selectable together with REM input)

- Current capacity: 30A or 50A CT to be specified when order is placed.
- Alarm action: Heater amperage detected by external CT (CT attached).
 Alarm output ON upon detection of heater break while control output is ON.
 Alarm output ON upon detection of heater loop alarm while control output is OFF.
- Current setting range: 0.1~50.0A (Alarm action stops when OFF is set.)
- Setting resolution: 0.1A
- Current display: 0.0~55.0A
- Display accuracy: Approx. 3% FS (for 50Hz/60Hz sine wave)
- Minimum time for action confirmation: ON (OFF) time 250 msec. min
- Alarm output/rating: Contact 240V AC 1.0A (resistive load)
- Alarm action display: "Event" lamp lights during action.
- Alarm holding mode: Switchable between holding and not holding on the setting screen.
- Sampling time: 500 msec. (0.5 sec.)
- Isolation: Insulated between CT input and various outputs (not insulated from system and other inputs)

■REMOTE (optional, not selectable together with heater break

- alarm)
- Remote setting: By external analog signal
 Switching to remote: By key, communication and DI (external switching) input (valid only when DI option is added)
 Remote/local switching function by remote signal
- Remote switching point: OFF, 0.1~50.0%
- Remote switching hysteresis: 0.1~10.0%
- Remote scaling: Within measuring range (inverted scaling possible)
 Accuracy of setting: $\pm(0.25\% SF + 1 \text{ digit})$
 Setting signal: 0~10V, 1~5V DC Input impedance: 500kΩ
 4~20mA DC Receiving impedance: 250Ω
- Remote bias: -1999~1999 units
- Remote filter: OFF, 1~100 sec.
- Sampling cycle: 500 msec. (0.5 sec.)
- Isolation: Insulated between remote input and various outputs (not insulated from system and various inputs)

■COMMUNICATION (optional, not selectable together with analog output for SR82 and SR84)

- Communication type (1): RS-232C, RS-485
- Communication system: RS-232C 3-line half duplex system
 RS-485 2-line half duplex multiple drop (bus) system
- Synchronization system: Start-stop synchronization system
- Communication distance: RS-232C maximum 15m
 RS-485 maximum 500m (depending on conditions)
- Communication speed: 1200, 2400, 4800, 9600, 19200 bps
- Data bit length: 7 bits, even parity, stop bit 1
 7 bits, even parity, stop bit 2
 7 bits, no parity, stop bit 1
 7 bits, no parity, stop bit 2
 8 bits, even parity, stop bit 1
 8 bits, even parity, stop bit 2
 8 bits, no parity, stop bit 1
 8 bits, no parity, stop bit 2
- Communication address: 1~99
- Communication memory mode: EEPROM/RAM/r_E
- Communication BCC: Add/Add two's cmp/XOR/None
- Communication delay time: OFF, 1~100
- Communication code: ASCII code
- Communication protocol: Shimaden standard protocol
- The number of instruments allowed to be connected: RS-232C 1
 RS-485 32 maximum (depending on conditions; host included)
- Isolation: Insulated between communication signal and various inputs/system/various outputs
- Communication type (2): Conforming with Mitsubishi Electric Company's CC-Link (only for SR83, simultaneous selection of analog output is not possible)
- Transmission speed: 156K, 625K, 2.5M, 5M, 10Mbps
- Private station: 1
- Communication method: Polling method
- Synchronization method: Frame synchronous method

- Coding system: NRZI system
- Transmission line: Bus (RS-485)
- Transmission format: Conforming with HDLC

■DI (EXTERNAL SWITCHING) INPUT (optional)

*DI stands for "Digital Input."

- Number of DI point: 2
- DI input type: Selectable from 8 types (7 types if the remote option is not added.)
 - NOP: No operation
 - STB: Execution/standby
 - SB/SV2: Set value bias/set value 2
 - AT: Auto tuning
 - MAN: Manual
 - STP: Ramp temporary stop
 - DA: Direct action
 - REM: Remote (selectable only when remote option is added)
- DI input rating: No-voltage contact, open collector input (about 5V/2mA impress)
- Isolation: Insulated between DI input and various outputs (not insulated from system and various inputs)

■SET VALUE 2 (SV2)/Set Value Bias (SB) (optional)
(DI option is prerequisite.)

- Action input: No-voltage contact by SB/SV2 selection through DI (external switching) input (in action during closed input)
- Selection of setting: Absolute value setting (SV2)
Deviation value setting (SB)
- Setting range: Absolute value setting:
Within measuring range
Deviation value setting:
-1999~5000 Units
SV2 allows PID and output limit to be set.

■OTHERS

- Data storage: By non-volatile memory (EEPROM)
- Ambient temperate/humidity ranges for use: -10~+50°C/below 90% RH (on condition that there is no dew condensation)
- Temperature for storage: Between -20 and +65°C
- Temperature range for maintaining accuracy: 23±5°C
- Power voltage: 100V-240V AC±10% (50/60 Hz),
24V AC±10% (50/60Hz),
24V DC±10%.
(One of the above to be specified)

- Power consumption: 12VA maximum
- Input noise removal ratio: Normal mode 60 dB minimum (50/60 Hz)
Common mode 140 dB minimum (50/60 Hz)
- Applicable standards: Safety: IEC1010-1 and EN61010-1
EMC: EN50081-2: 1993 (EMI/Emission)
EN50082-2, 1995 (EMS/Immunity)
- Insulation resistance: Between input/output terminals and power terminal 500V DC 20MΩ minimum
Between input/output terminals and protective conductor terminal 500V DC 20MΩ minimum
- Dielectric strength: 1 minute at 2300V AC between input/output terminals and power terminal
1 minute at 1500V AC between power terminal and protective conductor terminal
- Protective structure: Only front panel has simple dust-proof and drip-proof structure (equivalent to IP66)
- Material of case: PPO resin molding (equivalent to UL94V-1)
- External dimensions: SR82
H72 × W72 × D111mm
(Inside depth of panel: 100mm)
SR83
H96 × W96 × D111mm
(Inside depth of panel: 100mm)
SR84
H96 × W48 × D111mm
(Inside depth of panel: 100mm)
Push-in panel (one-touch mount)
- Mounting: 1.0~4.0 mm
- Applicable panel thickness:
- Panel cutout size: SR82: H68 × W68mm;
SR83: H92 × W92mm;
SR84: H92 × W45mm
- Weight: SR82: 300g;
SR83: 420g;
SR84: 280g

Distributed in New Zealand by:

Intech INSTRUMENTS LTD

Christchurch Auckland www.intech.co.nz
Ph: +6433430646 098271930 sales@intech.co.nz
Fx: +6433430649 098271931

The contents of this manual are subject to change without notice.

Temperature and Humidity Control Specialists
SHIMADEN CO., LTD.

Head Office: 2-30-10 Kitamachi, Nerima-Ku, Tokyo 179-0081 Japan
Phone: +81-3-3931-7891 Fax: +81-3-3931-3089
E-MAIL: exp-dept@shimaden.co.jp URL: <http://www.shimaden.co.jp>

PRINTED IN JAPAN