

SR253 Series
Digital Controller
COMMUNICATION INTERFACE
(RS-232C/RS-422A/RS-485)
OPERATING INSTRUCTIONS

Thank you for your purchase of our product. Please check that the product is exactly as ordered by you and read and understand this operating instruction manual for a full understanding of the product so that you may use it properly.

CONTENTS

<p>1. General 1</p> <p>2. Specification 1</p> <p>3. Connection of Controller to Host Computer 2</p> <p style="padding-left: 20px;">3-1 RS-232C 2</p> <p style="padding-left: 20px;">3-2 RS-422A, RS-485 2</p> <p style="padding-left: 20px;">3-3 Terminal Resistor 3</p> <p style="padding-left: 20px;">3-4 Control of 3-state Output 3</p> <p>4. Communication-related Settings 4</p> <p style="padding-left: 20px;">4-1 Indication of Communication System 4</p> <p style="padding-left: 20px;">4-2 Setting of Machine Address 4</p> <p style="padding-left: 20px;">4-3 Setting of Communication Rate 4</p> <p style="padding-left: 20px;">4-4 Setting of Communication Data Format 4</p> <p style="padding-left: 20px;">4-5 Setting of Communication Protocol Mode 5</p> <p style="padding-left: 20px;">4-6 Setting of Communication Memory Mode 5</p> <p style="padding-left: 20px;">4-7 Setting of Control Codes 5</p> <p style="padding-left: 20px;">4-8 Setting of Check Sum 5</p> <p style="padding-left: 20px;">4-9 Setting of Delay Time 5</p> <p>5. An Outline of Communication Protocols 6</p> <p>6. Standard Protocol 6</p> <p style="padding-left: 20px;">6-1 Communication Procedure 6</p> <p style="padding-left: 20px;">6-2 Communication Format 6</p> <p style="padding-left: 20px;">6-3 Details of Read Command (R) 10</p> <p style="padding-left: 20px;">6-4 Details of Write Command (W) 12</p> <p style="padding-left: 20px;">6-5 Details of Response Codes 13</p> <p style="padding-left: 20px;">6-6 A List of Communication Data Addresses 14</p>	<p>7. SR25 Compatible Protocol 29</p> <p style="padding-left: 20px;">7-1 Communication Procedure 29</p> <p style="padding-left: 20px;">7-2 Control Codes 29</p> <p style="padding-left: 20px;">7-3 Establishment and Abandonment of Data Link 29</p> <p style="padding-left: 20px;">7-4 Communication Format 30</p> <p style="padding-left: 20px;">7-5 Communication Modes (CM Commands) 32</p> <p style="padding-left: 20px;">7-6 Commands 33</p> <p style="padding-left: 20px;">7-7 A List of Commands 33</p> <p style="padding-left: 20px;">7-8 Details of Common Formats 37</p> <p style="padding-left: 20px;">7-9 Details of Commands Common to SR25 and SR253 37</p> <p style="padding-left: 20px;">7-10 Details of Added Commands for SR253 40</p> <p style="padding-left: 20px;">7-11 Details of SR25 Substitution Commands 42</p> <p>8. Supplementary Explanation 45</p> <p style="padding-left: 20px;">8-1 Tables of Measuring Ranges 45</p> <p style="padding-left: 20px;">8-2 COMDIR 46</p> <p>9. A Table of ASCII Codes 46</p>
---	---

SHIMADEN CO., LTD.

SR253C-1CE,
Nov. 2001

This operating instruction manual describes the communication interface as an optional function of the Digital Controller SR253 Series. For details of how the SR253 operates and its parameters, please refer to the separate Instruction Manual of the controller itself.

1. General

As a communication interface for the SR253 series, three types of communication systems; RS-232C, RS-422A and RS-485 are available. Each can set and read the various data of the SR253 by means of signals which conform with the EIA Standards through a personal computer or the like.

RS-232C, RS-422A and RS-485 are data communication standards provided by the Electronic Industries Association (EIA). The standards cover electric and mechanical points, that is, they refer only to so-called hardware but do not touch on the software aspects of the data transmission procedure. This precludes the possibility of communicating unconditionally by a device equipped with the same interface. Therefore, users need to have full knowledge of the specifications and transmission procedure.

Use of RS-422A or RS-485 allows parallel connection of multiple SR253 series controllers. Although there are a smaller number of personal computers and the like which support this interface, a line converter for the following conversion can be used:

RS-232C <-----> RS-485

RS-232C <-----> RS-422A

2. Specifications

Signal level:	In conformity with EIA RS-232C, RS-422A and RS-485	
Communication system:	RS-232C	3-wire type half duplex system
	RS-422A	4-wire type half duplex multi-drop(bus) system
	RS-485	2-wire type half duplex multi-drop(bus) system
Synchronization system:	Half duplex start-stop system	
Communication distance:	RS232C	15 m maximum
	RS-422A	1200 m maximum in total (depends on conditions)
	RS-485	500 m maximum in total (depends on conditions)
Communication rate:	1200, 2400, 4800, 9600 and 19200 BPS	
Transmission procedure:	No procedure	
Data format:	Data length 7 bits, even parity check, stop bit 1	
	Data length 7 bits, even parity check, stop bit 2	
	Data length 7 bits, no parity, stop bit 1	
	Data length 7 bits, no parity, stop bit 2	
	Data length 8 bits, even parity check, stop bit 1	
	Data length 8 bits, even parity check, stop bit 2	
	Data length 8 bits, no parity, stop bit 1	
	Data length 8 bits, no parity, stop bit 2	
Communication codes:	ASCII codes	
Isolation:	Between communication signals and various inputs, the system and various outputs	

3. Connection of Controller to Host Computer

The SR253 series controller has only three lines for inputs/outputs, i.e., transmission data, received data and grounding for signals and no other signal line is provided. Thus, it has no control line and control signals have to be processed by a host computer. In this instruction manual, an example of the processing methods affecting control signals is shown in diagrams (darkened ground portions) but the actual method differs from system to system. For details, refer to the specifications of your host computer.

3-1 RS-232C

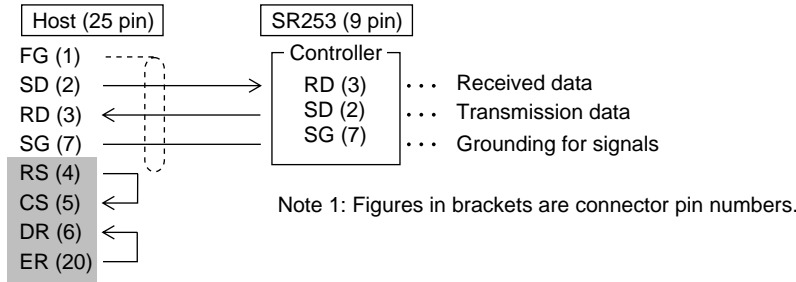

3-2 RS-422A, RS-485

The input/output logical levels of the SR253 series are basically as follows:

[RS-422A]

Marking ****-< **+** (Example SD - < SD+)

Spacing ****-> **+** (Example SD - > SD+)

[RS-485]

Marking **- Terminal < + Terminal**

Spacing **- Terminal > + Terminal**

Nevertheless, the SD+, SD-, + terminal and - terminal of the controller are in a state of high impedance before starting transmission and the above levels are reached immediately before the start of transmission. (See 3-4 "Control of 3-state Output".)

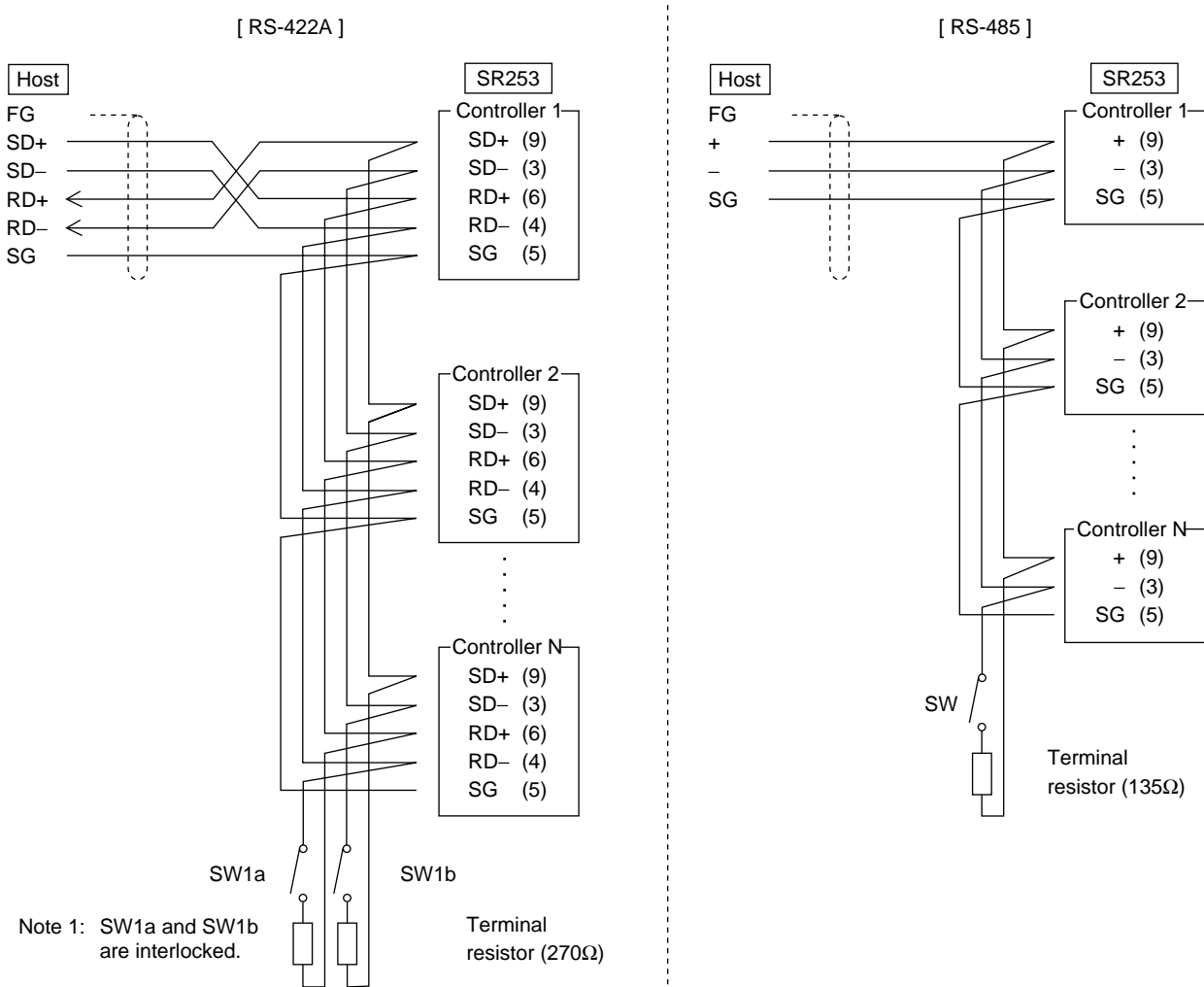

Note 1: SW1a and SW1b are interlocked.

Note 2: For terminal impedance, see 3-3 "Terminal Resistor".

3-3 Terminal Resistor

The controller of the RS-422A or RS485 specification has a built-in terminal resistor. Draw out the instrument from its case upon necessity and turn the switch ON (SW1a and SW1b are interlocked in the case of RS-422A). The terminal resistor of only the last controller should be turned ON. If you turn the terminal resistors of two or more controllers ON, their proper functioning cannot be guaranteed.

(1) How to draw out the instrument from its case

Caution!

When the instrument is taken out of or replaced back into its case, make sure to turn the power off. If it is removed or replaced while the power is on, it may lead to failure of or damage to the controller.

Usually the SR253 controller need not be drawn out of its case. When it is necessary to draw it out in order to turn the terminal resistor ON, it should be done as follows:

Insert a minus screwdriver of 6 mm to 8 mm in width into the cut (the portion in which rubber is exposed) on the bottom of the front case and rotate the screwdriver while pressing the lock lever in the depth of the portion where the rubber is exposed.

Once the body of the controller is moved forward by a few millimeters, pull out it by gripping it with your hands.

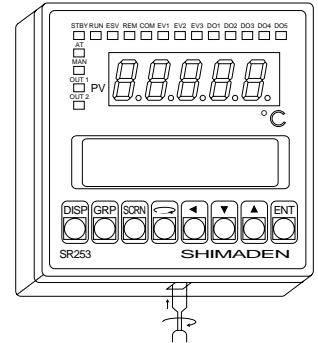

Note 1: Take care not to impair the rubber in inserting the screwdriver.

(2) How to turn the terminal resistor ON

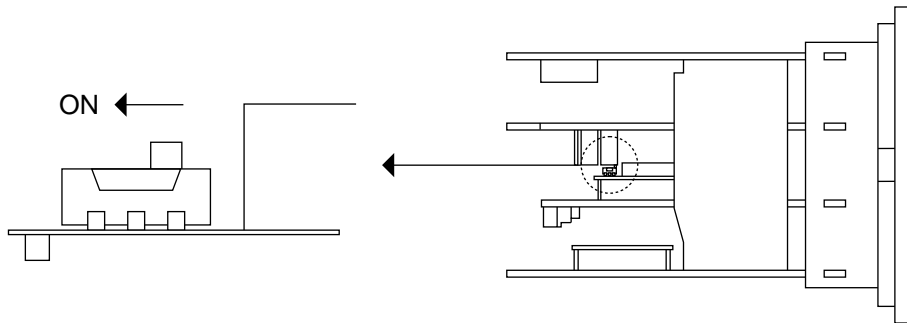

Note 2: The above is a bottom view of the instrument taken out of its case.

3-4 Control of 3-state Output

Since RS-422A and RS-485 are of the multi drop system, transmitting output is always in a state of high impedance while not in communication or during reception, in order to avoid any collision of transmitted signals.

It is so controlled that high impedance is changed to the state of normal output right before transmission is carried out and the high impedance state returns immediately upon completion of transmission. Since the 3-state control is about 1 msec (max.) behind the end bit transmission of an end character, however, a delay time of approximately a few msec or longer should be provided in case transmission is started immediately when reception by the host side finishes.

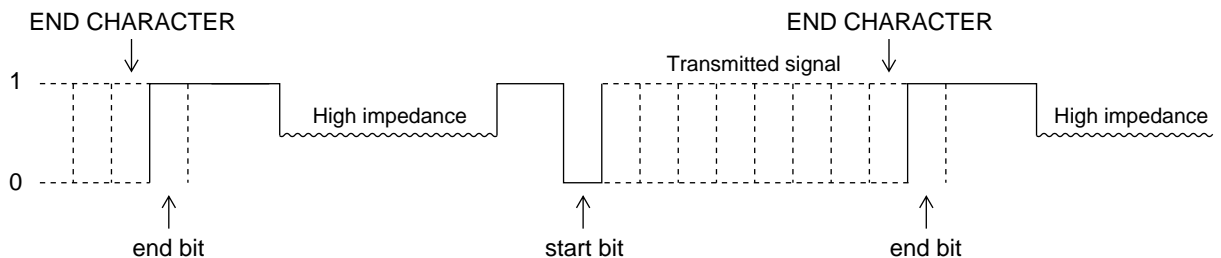

4. Communication-related Settings

In the SR253 series, there are the following eight parameters related to communication. These parameters are unable to be set or changed through communication; this must be done by front key operation. In setting these parameters, refer to 5. "LCD Screen Parameter Diagram" of the Operating Instructions of the controller and follow the steps shown there.

Use the **GRP** key to move to the OPTION screen group (Group 5-0) and call the communication-related setting screen (Group 5-5A) by the use of the **SCRN** key. To select a parameter in the screen, use the  key.

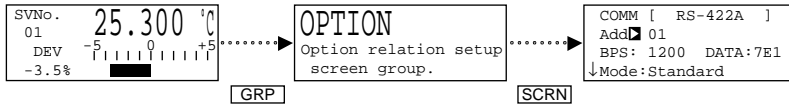

4-1 Indication of Communication System (Group 5-5A)

Indication of communication system

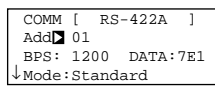

Note 1: Please check that the communication system is as you specified.

4-2 Setting of Machine Address (Group 5-5A)

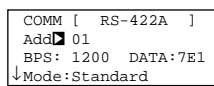

Setting range: 01 ~ 99
Initial value: 01

In the RS-232C, only one SR253 can be connected to a host computer whereas in the case of RS-422A or RS-485, which is of the multi drop system, up to 32 instruments can be connected to one host computer. Nonetheless, actual communication should be from one to one and so the instruments need to be distinguished by means of addresses (machine numbers) assigned to them so that only a designated instrument can respond.

Note 1: Addresses are from 01 to 99, which can be set to 32 types of instruments maximum.

4-3 Setting of Communication Rate (Group 5-5A)

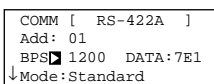

Setting range: 1200, 2400, 4800, 9600, 19200
Initial value: 1200

The rate of communication is selectable from 1200, 2400, 4800 and 19200 BPS. Select one and set it.

4-4 Setting of Communication Data Format (Group 5-5A)

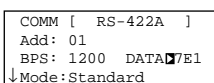

Setting range: The following 8 types
Initial value: 7E1

A communication data format is selectable from the following eight types. Select one and set it.

Type of format	Length of data	Parity	Stop bit
7E1	7bit	EVEN	1
7E2	7bit	EVEN	2
7N1	7bit	None	1
7N2	7bit	None	2
8E1	8bit	EVEN	1
8E2	8bit	EVEN	2
8N1	8bit	None	1
8N2	8bit	None	2

4-5 Setting of Communication Protocol Mode (Group 5-5A)

```
COMM [ RS-422A ]
Add: 01
BPS: 1200 DATA:7E1
↓Mode: Standard
```

Setting range: SR25 Mode, Standard
Initial value: Standard

SR25 Mode: SR25 compatible protocol → Employed in order to adapt to SR25 when SR253 is used together with SR25.
Standard: Standard protocol for SR253

4-6 Setting of Communication Memory Mode (Group 5-5B)

```
MEM  EEP
CTRL: STX_ETX_CR
BCC : Add
DELY: 10
```

Setting range: EEP, RAM
Initial value: EEP

Since the number of write cycles of EEPROM is limited, frequent rewriting of SV data through communication shortens the life of EEPROM. To prevent this, when data needs to be rewritten frequently, the RAM mode is set so that only RAM data can be re-written without changing EEPROM. This can extend the life of EEPROM.

- EEP mode: In the EEP mode, EEPROM data is also rewritten when data is changed through communication. Accordingly, data is retained after turning the power OFF.
- RAM mode: In the RAM mode, changing the date through communication rewrites RAM data only but EEPROM data is not rewritten. Accordingly, when power is turned OFF, RAM data is erased and upon reapplying power, the instrument is reactivated in accordance with data stored in EEPROM.

Note 1: If you want to store a PID value in EEPROM, execute AT in the EEP, and once the PID value is computed, change to the RAM mode and start communication.

4-7 Setting of Control Codes (Group 5-5B)

```
MEM : EEP
CTRL STX_ETX_CR
BCC : Add
DELY: 10
```

Setting range: STX_ETX_CR, STX_ETX_CRLF, @ :_CR
Initial value: STX_ETX_CR

Select control codes to be used.

Note 1: When you select the SR25 compatible protocol, this parameter cannot be set.

4-8 Setting of Check Sum (Group 5-5B)

```
MEM : EEP
CTRL: STX_ETX_CR
BCC  Add
DELY: 10
```

Setting range: Add, Add_two's cmp, XOR, None
Initial value: Add

Select a BCC operation method to be used in BCC checking.

For details, refer to "BCC Data" in (3) "Details of Basic Format Portion II" of 6-2 "Communication Format."

Note 1: When you select the SR25 compatible protocol, this parameter cannot be set.

4-9 Setting of Delay Time (Group 5-5B)

```
MEM : EEP
CTRL: STX_ETX_CR
BCC : Add
DELY 10
```

Setting range: 0 ~ 99
Initial value: 40

A minimum time of delay from reception of a communication command to a transmission can be set.

$$\text{Delay time (msec)} = \text{Set value (count)} \times 0.25 \text{ (msec)}$$

Note 1: In the case of RS-485, some of line converters take a longer time for 3-state control to cause signal collision. If this is the case, prevention is possible by increasing the delay time. Care should be taken particularly when the communication rate is low (for example, 1200 bps and 2400 bps).

Note 2: If set value = 0, set value = 1 is used for internal operation.

Note 3: Actual delay time from reception of a communication command to transmission is the total of the above-described delay time and time required to process the command by software. Particularly, if it is a write command, the command processing time may be as long as about 400 msec.

5. An Outline of Communication Protocols

For the SR253 series, two types of communication protocols are available. Use the front key for selection. (See 4-5 "Setting of Communication Protocol Mode.")

- 1) Standard: SR253 standard protocol
- 2) SR25 Mode: SR25 compatible protocol.....Used to adapt to SR25 when SR253 is used together with SR25.

6. Standard Protocol

6-1 Communication Procedure

(1) Master/Slave Relation

- A personal computer or PLC (host) is the master side.
- SR253 is the slave side.
- Communication is started by a communication command from the master side and ends with a communication response from the slave side. If a communication format error, a BCC error or other abnormality is recognized, however, no communication response will be made. No communication response is made to a broadcast instruction, either.

(2) Communication Procedure

Communication proceeds while the transmission right is passed over alternately in the form of the slave side responding to the master side.

(3) Time Out

- In the event reception of an end character does not finish within the following periods of time after receiving a start character, the controller takes it as a time out and waits for another command (a new start character). Therefore, if the length of time of time out is set by the host side, a longer time than those which are shown in the table below should be set:

Communication rate	Length of time of time out
1200, 2400 BPS	2 seconds
4800, 9600, 19200 BPS	1 seconds

6-2 Communication Format

The SR253 allows for a variety of communication formats (start character, text end character, end character and BCC operating method) and communication data formats (data bit length, whether or not of parity, and stop bit length) for easy compliance with other protocols.

Nonetheless, the following serves as their basic format and you are encouraged to use them uniformly:

• Communication format

Control code (start character, text end character, end character)→STX_ETX_CR

Check sum (BCC operating method)→Add

• Communication data format (data bit length, whether or not of parity, stop bit length)→7E1 or 8N1

For setting a communication format and a communication data format, see "4. Setting of parameters related to communication."

(1) An Outline of Communication Format

The communication format is composed of the basic format portion I, text portion and basic format portion II.

1) Communication Command Format

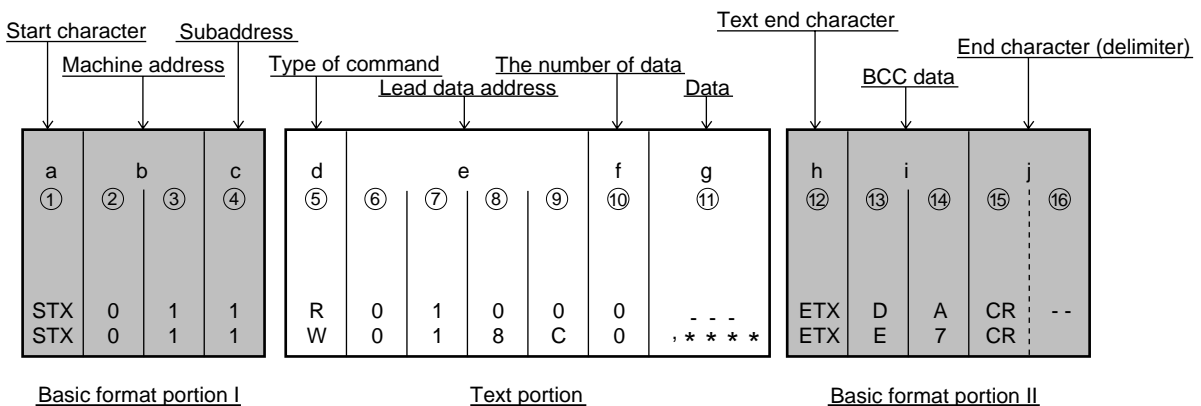

2) Communication Response Format

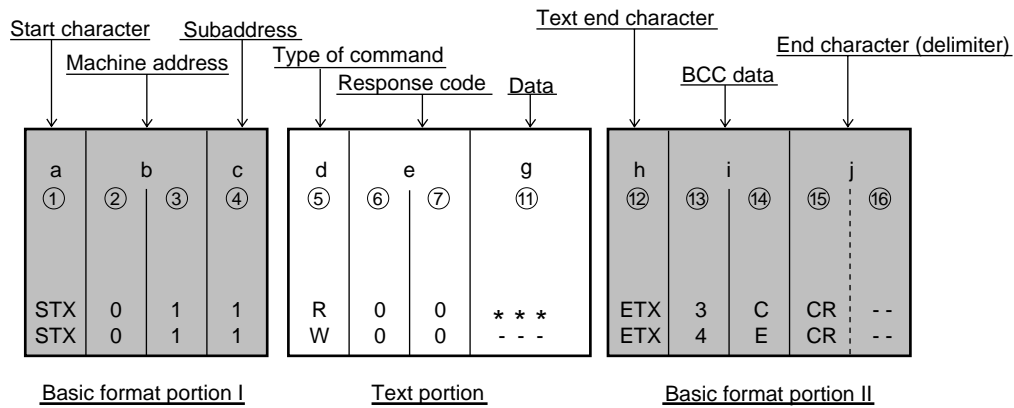

- The basic format portions I and II are common to read command (R), write commands (W) and communication responses. Nevertheless, regarding BCC data of i (⑬, ⑭), data as the result of operation is inserted each time.
- The text portion varies according to command types, data addresses, communication responses and the like.

(2) Details of Basic Format Portion I

a: Start character [① : 1 digit / STX (02H) or "@" (40H)]

- Indicates that it leads a communication sentence.
- When a start character is received, it is judged to be the first character of a new communication sentence.
- A start character and a text end character are selected as a couple. (See 4-7 "Setting of Control Codes.")
Selected as STX (02H) ---- ETX (03H)
Selected as "@" (40H) ---- " : " (3AH)

b: Machine address [②, ③ : 2 digits]

- Designates an instrument to communicate with.
- An address can be designated in a range from 1 to 99 (decimal).
- Binary 8 bit data (1:0000 0001 ~ 99:0110 0011) is divided to two groups of 4 bits, i.e., the most to 4th most significant bits and the 5th most to least significant bits and converted to ASCII data.
② : ASCII data converted from the most to 4th most significant bits
③ : ASCII data converted from the 5th most to least significant bits
- Since Machine address = 0 (30H, 30H) is used at the time of broadcast instruction, it cannot be used as a machine address. SR253 does not support broadcast instruction. Therefore, Address = 0 receives no response.

c: Subaddress [④ : 1 digit]

- Because SR253 is a single loop controller, it is fixed to ④ = 1 (31H). If any other address is designated, it becomes a subaddress error and no response is received.

(3) Details of Basic Format Portion II

h: Text end character [⑫ : 1 digit / ETX (03H) or " : " (3AH)]

- Indicates that a text ends immediately before it.

i: BCC data [⑬, ⑭ : 2 digits]

- BCC (block check character) data checks communication data for any abnormality.
- In case the result of BCC operation reveals a BCC error, no response will be made.
- There are the following 4 types of BCC operation. (A type of BCC operation can be set on the front screen.)

(1) BCC Add

Add operation is carried out on each character (1 byte) of ASCII data from start character ① to text end character ⑫ .

(2) BCC Add_two's cmp

Add operation is carried out on each character (1 byte) of ASCII data from start character ① to text end character ⑫ and a two's complement of 1 byte in the least significant digit of the operation result is taken.

(3) BCC XOR

XOR (exclusive OR) operation is carried out on each character (1 byte) of ASCII data from right after start character (machine address ②) to text end character ⑫.

(4) BCC None

No BCC operation is carried out. (⑬, ⑭ are omitted.)

- Regardless of the data bit length (7 or 8), operation is carried out on each byte (8 bits).
- The least significant 1 byte of data obtained from the above operation is divided into two groups of 4 bits, i.e., the most to the 4th most significant bits and the 5th most to the least significant 4 bits and converted into ASCII data.

⑬: ASCII data converted from the most to the 4th most significant bits

⑭: ASCII data converted from the 5th most to the least significant bits

Example 1 In the case of BCC ▶ Add and read command (R):

①	②	③	④	⑤	⑥	⑦	⑧	⑨	⑩	⑫	⑬	⑭	⑮	⑯
STX	0	1	1	R	0	1	0	0	0	ETX	D	A	CR	
02H +30H +31H +31H +52H +30H +31H +30H +30H +30H +03H = 1DAH														

The last 1 byte of the result of add operation (1DAH) = DAH

⑬: "D" = 44H, ⑭: "A" = 41H

Example 2 In the case of BCC ▶ Add_two's cmp, and read command (R):

①	②	③	④	⑤	⑥	⑦	⑧	⑨	⑩	⑫	⑬	⑭	⑮	⑯
STX	0	1	1	R	0	1	0	0	0	ETX	2	6	CR	
02H +30H +31H +31H +52H +30H +31H +30H +30H +30H +03H = 1DAH														

The last 1 byte of the result of add operation (1DAH) = DAH

The two's complement of the last 1 byte (DAH) = 26H

⑬: "2" = 32H, ⑭: "6" = 36H

Example 3 In the case of BCC ▶ XOR, and read command (R):

①	②	③	④	⑤	⑥	⑦	⑧	⑨	⑩	⑫	⑬	⑭	⑮	⑯
STX	0	1	1	R	0	1	0	0	0	ETX	5	0	CR	
02H ⊕30H ⊕31H ⊕31H ⊕52H ⊕30H ⊕31H ⊕30H ⊕30H ⊕30H ⊕03H = 50H														

⊕ = XOR (exclusive OR), through:

The last 1 byte of the result of operation (50H) = 50H

⑬: "5" = 35H, ⑭: "0" = 30H

j: End character (delimiter) [⑮, ⑯: 1 digit or 2 digits/CR or CR LF]

- Indicates that it is the last of a communication sentence.
- An end character can be selected from the following two:
 - ⑮, ⑯: CR (0DH) (Only CR, LF is not added.)
 - ⑮, ⑯: CR (0DH), LF (0AH)

(4) Conditions Common to Basic Format Portions I and II

1. If any of the following abnormalities is found in a basic format portion, there will be no response:
 - There is a hardware error.
 - The machine address or the subaddress is different from the address of a designated machine.
 - A character fixed in the above-described communication format is not in its fixed position.
 - The result of BCC operation is different from BCC data.
2. Binary data is converted, with 4 bits as a unit, into ASCII data.
3. Hexadecimal <A> ~ <F> are converted into ASCII data by using capital letters.

(5) An Outline of Text Portion

The text portion varies according to command types and communication responses.

For details of the text portion, refer to 6-3 "Details of Read Command (R)" and 6-4 "Details of Write Command (W)."

d: Types of Commands [⑤ : 1 digit]

- "R"(52H/capital letter): Indicates that it is a read command or a response to a read command. Used when various data is to be read (taken in) from a personal computer, PCL or the like into SR253.
- "W"(57H/capital letter): Indicates that it is a write command or a response to a write command. Used when various data from a personal computer, PCL or the like is to be written into (changed in) SR253.
- "B"(42H/capital letter): Indicates that it is a broadcast instruction. Since SR253 supports no broadcast instruction, this cannot be used.
- In the event any character other than "R" and "W" is recognized, there will be no response.

e: Lead data address [⑥ , ⑦ , ⑧ , ⑨ : 4 digits]

- Designates the lead data address of what is read or written in a read command (R) or a write command (W).
- The lead data address is designated by binary 16 bit (1 word /0 ~ 65535) data.
- The 16 bit data is divided into groups of 4 bits and converted into ASCII data.

Binary (16 bits)	D15, D14, D13, D12 0 0 0 0	D11, D10, D9, D8 0 0 0 1	D7, D6, D5, D4 1 0 0 0	D3, D2, D1, D0 1 1 0 0
Hexadecimal (Hex)	0H " 0 "	1H " 1 "	8H " 8 "	CH " C "
ASCII data	30H ⑥	31H ⑦	" 38 " ⑧	43H ⑨

- For data addresses, refer to 6-6 "A List of Communication Data Addresses".

f: The number of data [⑩ : 1 digit]

- Designates the number of data to be read or written in a read command (R) or a write command (W).
- The number of data is designated by converting binary 4 bit data into ASCII data.
- In the case of a read command (R), designation is possible in the following range:
"0" (30H) (one) ~ "9" (39H) (ten)
- In the case of a write command (W), it is fixed to "0"(30H) (one).
- That actual number of data is <The number of data = designated number + 1>.

g: Data [⑪ : The number of digits depends on the number of data]

- Designated data to be written (changed) in the case of a write command (W) and data to be read in the case of a response to a read command (R).
- The data format is as follows:

g (⑪)

," 2CH	First data				Second data				nth data			
	The most significant digit	The second most significant digit	The third most significant digit	The least significant digit	The most significant digit	The second most significant digit	The third most significant digit	The least significant digit	The most significant digit	The second most significant digit	The third most significant digit	The least significant digit

- A comma (," 2CH) is always added at the head of data to show that data follows it.
- No mark is used between data.
- The number of data depends on the number of data (f: ⑩) in the communication command format.
- Data is expressed by binary 16 bits excluding a decimal point as a unit (one word). The position of the decimal point is fixed in each data.
- 16 bit data is divided into groups of 4 bits and each group is converted into ASCII data.
- For details on data, please refer to 6-3 "Details of Read Command (R)" and 6-4 "Details of Write Command (W)."

e: Response Code [⑥, ⑦ : 2 digits]

- Designates a response code to a read command (R) or a write command (W).
- Binary 8 bit data (0 ~ 255) is divided into 2 groups of 4 bits of the most significant to 4th most significant digits and of the 5th to the least significant digits, and each of them is converted to ASCII data.
 - ⑥ : ASCII data converted from the most to 4th most significant bits
 - ⑦ : ASCII data converted from the 5th most to least significant bits
- In the case of a normal response, "0"(30H),"0"(30H)" is designated.
- In the case of an abnormal response, an abnormal code No. is converted into ASCII data and designated.
- For details of response codes, refer to 6-5 "Details of Response Code."

6-3 Details of Read Command (R)

Read commands are used when various data of SR253 are read (taken in) from a personal computer, PLC or the like.

(1) Read Command (R) Format

- The following is the format of the text portion of a read command: (The basic format portions I and II are common to all the commands and the responses.)

Text portion

d ⑤	⑥	e ⑦	⑧	⑨	f ⑩
R 52H	0 30H	3 33H	0 30H	0 30H	9 39H

- d: Indicates that it is a read command.
- e: Designates a lead data address of data to be read.
- f: Designates, for reading, the number (words) of data following the lead data address.

- The above command is:

Lead data address of data to be read = 0300H (hexadecimal)
 = 0000 0011 0000 0000 (binary)

The number of data to be read = 9H (hexadecimal)
 = 1001 (binary)
 = 9 (decimal)

(The actual number of data) = 10 (9 + 1)

Thus, it designated reading of ten data following the data address 0300H.

(2) Format of Normal Response to Read Command (R)

- The following is the normal response format (text portion) to a read command (R).
 (The basic command portions I and II are common to all the commands and the responses.)

Text portion

d ⑤	e ⑥	⑦													
			first data				g ⑪	second data				10th data			
R 52H	0 30H	0 30H	, 2CH	0 30H	0 30H	6 36H	4 34H	0 30H	0 30H	6 36H	E 45H			
												0 30H	0 30H	B 42H	E 45H

- d (⑤): <R (52H)> indicating that it is a response to a read command (R) is inserted.
- e (⑥, ⑦): <00 (30H, 30H)> indicating that it is a normal response to the read command (R) is inserted.
- g (⑪): Response data to the read command (R) is inserted.
 The format of the data is as follows:
 1. First, <2CH> showing that it is the head of data is inserted.
 2. Next, as much data as <the number of data to be read> is inserted sequentially, starting from <data of the lead data address for reading>.
 3. Nothing is inserted between data.

4. Each data comprises binary 16 bits (one word) data excluding decimal points, and it is converted, 4 bits as a unit, into ASCII data.
5. The position of a decimal point is fixed for each data.
6. The number of characters of response data is:
The number of characters = 1 + 4 × the number of data to be read.

- In answer to a read command (R) as stated above, the following data is transmitted sequentially:

	Data address 16 bits (1 word)	Data 16 bits (1 word)	
	Hexadecimal	Hexadecimal	decimal
	02FF	0000	0
Lead data address for reading (0300H) →	0300	0064	100
	0301	006E	110
	0302	0078	120
	0303	0082	130
The number of data to be read (9H: 10)	0304	008C	140
	0305	0096	150
	0306	00A0	160
	0307	00AA	170
	0308	00B4	180
	0309	00BE	190
	030A	0000	0
	030B	07D0	2000
	030C	0000	0

Response data 0064H: 100 (10.0°C) ~ 00BEH: 190 (19.0°C)
(SV1 ~ SV10 to be read in a measuring range of 0.0 ~ 200.0°C)
Thus, the above data can be read.

(3) Abnormal Response Format to Read Command (R)

- The following is the abnormal response format (text portion) to a read command (R). (The basic format portions I and II are common to all the commands and the responses.)

Text Portion

d	e	
⑤	⑥	⑦
R	0	7
52H	30H	37H

- d (⑤):<R (52H)> indicating that it is a response to a read command (R) is inserted.
- e (⑥, ⑦): A response code indicating that it is an abnormal response to the read command (R) is inserted.
- For details of abnormal codes, refer to 6-5 "Details of Abnormal Codes."
- No response data is inserted in an abnormal response.

6-4 Details of Write Command (W)

Write commands (W) are used to write (change) various data from a personal computer, PCL or the like in SR253.

To use a write command, the parameter on the LCD Screen Group 1-2 operation needs to be changed from LOCAL to COMM. Since this change is unable to be made through the front key, change it through the following command communication: (In the case of Add ▶ 01,

CTRL▶STX_ETX_CR, BCC▶ADD)

Command format

STX	0	1	1	W	0	1	8	C	0	,	0	0	0	1	ETX	E	7	CR
02H	30H	31H	31H	57H	30H	31H	38H	43H	30H	2CH	30H	30H	30H	31H	03H	45H	37H	0DH

When the above command is sent and a normal response is received, the COM LED lamp lights and the change to Operation Comm is accomplished.

(1) Write Command (W) Format

- The following is the format of the text portion of a write command (W):
(The basic format portions I and II are common to all the commands and the responses.)

Text Portion										
d	e				f	g				
⑤	⑥	⑦	⑧	⑨	⑩	⑪				
W	0	3	0	0	0	,	0	0	C	8
57H	30H	33H	30H	30H	30H	2CH	30H	30H	43H	38H
							Data to be written			

- d: Indicates that it is a write command. This is fixed to "W" (57H).
- e: Designates lead data address of data to be written (changed).
- f: Designates the number of data to be written (changed). The number of data is fixed to "0" (30H), i.e., one.
- g: Designates data to be written (changed).
 - First, <(2CH)> showing that it is the head of data is inserted.
 - Next, data to be written is inserted.
 - Data comprises binary 16 bits (one word) data excluding a decimal point, and it is converted, 4 bits as a unit, into ASCII data.
 - The position of a decimal point is fixed for each data.

- The above command is:

Lead data address of data to be written = 0300H (hexadecimal)
= 0000 0011 0000 0000 (binary)

The number of data to be written = 0H (hexadecimal)
= 0000 (binary)
= 0 (decimal)

(The actual number of data) = 1 (0 + 1)

Data to be written = 00C8H (hexadecimal)
= 0000 0000 1100 1000 (binary)
= 200 (decimal)

Thus, it designates writing (change) of one datum (200: decimal) of a data address of 0300H.

Lead data address (300H) for writing → 0
The number of data to be written: 1 (0H)

Data address 16 bits (1 word)		Data 16 bits (1 word)	
Hexadecimal	Decimal	Hexadecimal	Decimal
02FF	767	0000	0
0300	768	00C8	200
0301	769	006E	110
0302	770	0078	120

(2) Format of Normal Response to Write Command (W)

- The following is the normal response format (text portion) to a write command (R).
(The basic command portions I and II are common to all the commands and the responses.)

text portion

d ⑤	e ⑥ ⑦	
W 57H	0 30H	0 30H

- d (⑤): <W (57H)> indicating that it is a response to a write command (W) is inserted.
- e (⑥, ⑦): A response code, <00 (30H, 30H)> indicating that it is a normal response to the write command (W) is inserted.

(3) Abnormal Response Format to Write Command (W)

- The following is the abnormal response format (text portion) to a write command (W).
(The basic format portions I and II are common to all the commands and the responses.)

text portion

d ⑤	e ⑥ ⑦	
W 57H	0 30H	9 39H

- d (⑤): <W (57H)> indicating that it is a response to the write command (R) is inserted.
- e (⑥, ⑦): A response code indicating that it is an abnormal response to the write command (W) is inserted.
- For details of abnormal codes, refer to 6-5 "Details of Abnormal Codes."

6-5 Details of Response Codes

(1) Types of Response Codes

- A communication response to a read command (R) or a write command (W) always includes a response code.
- Response codes are broadly divided into the following two types:

Response codes: { Normal response codes
Abnormal response codes

- A response code comprises binary 8 bit data (0 ~ 255).

- The types of response codes are listed in the following:

A List of Response Codes

Response code		Type of code	Description
Binary	ASCII		
0000 0000	"0", "0" : 30H, 30H	Normal response	Normal response to read command (R) or write command (W)
0000 0001	"0", "1" : 30H, 31H	Hardware error in text portion	Hardware error such as framing overrun or parity is detected in data in text portion.
0000 0111	"0", "7" : 30H, 37H	Format error in text portion	Format of text portion is different from what has been specified.
0000 1000	"0", "8" : 30H, 38H	Error in data of text portion, data address or the number of data	Data format of text portion is different from specified format, or data address or the number of data is not that which has been designated.
0000 1001	"0", "9" : 30H, 39H	Data error	Data to be written is out of the range in which the data can be set.
0000 1010	"0", "A" : 30H, 41H	Execution command error	Execution command is received under condition in which execution command (such as MAN command) is unacceptable.
0000 1011	"0", "B" : 30H, 42H	Write mode error	Some types of data are not allowed to be changed at certain times. Write command including such data is received at such a time.
0000 1100	"0", "C" : 30H, 43H	Error in specification or option	Received write command includes specification or option which is not added.

(2) Priority Order of Response Codes

The smaller the value of response code, the higher the priority. When a plurality of response codes are generated, the one which has the highest priority is returned.

6-6 A List of Communication Data Addresses

(1) Data Address and Read/Write

- In data addresses, every 4 bits of binary numbers (16 bit data) are expressed in hexadecimal numbers.
- R/W means data that can be read or written.
- R means read only data.
- W means write only data.
- When a read command (R) designates a write only data address, or a write command (W) designates a read only data address, it is taken as a data address error and an abnormal response code "0," "8" (30H, 38H) "Error in data format, data address or the number of data in text portion" is received.

(2) Data Address and the Number of Data

- In case a data address which is not included in data addresses for SR253 is designated as a lead data address, an abnormal response code "0," "8" (30H, 38H) "Error in data format, data address or the number of data in text portion" is sent back.
- Even when a lead data address is included in the listed data addresses, if a data address added with the number of data is out of the range of the listed data addresses, it is taken as an error in the number of data and an abnormal response code "0," "8" (30H, 38H) is sent back.
- The *200H level of data addresses is a long data (2 words/32 bits) area and so a lead data address and a data number needs to be designated by even data. If designated by odd data, an abnormal response code "0," "8" (30H, 38H) is sent back.

(3) Data

- Since each datum is a binary number (16 bit data) without a decimal point, the form of datum and whether it has a decimal point or not should be checked. (Refer to the Instruction Manual of the instrument itself.)

Example) How to express data with decimal points

Hexadecimal data

20.0% → 200 → 00C8
 100.00°C → 10000 → 2710
 -40.00°C → -4000 → F060

- Concerning the data of a unit, the position of a decimal point depends on its measuring range.
- In the case a special measuring range (such as 0 ~ 50.000°C exceeding 32768) and data depends on the measuring range, it is expressed by a binary number without a code (16 bit data: 0 ~ 65535).
- Data except those mentioned above is expressed by a binary number with a code (16 bit data: -32768 ~ 32767).

Example) How to express 16 bit data

Data with code		Data without code	
Decimal	Hexadecimal	Decimal	Hexadecimal
0	0000	0	0000
1	0001	1	0001
⋮	⋮	⋮	⋮
32767	7FFF	32767	7FFF
-32768	8000	32768	8000
-32767	8001	32769	8001
⋮	⋮	⋮	⋮
-2	FFFE	65534	FFFE
-1	FFFF	65535	FFFF

(4) <Reserve> of Parameter Portion

- In case a read command (R) designates the reading of the <reserve> portion, (0000H) data is sent back.
- In case a write command (W) designates to write the <reserve> portion, a normal response code "0," "0" (30H, 30H) is sent back but no change of data is carried out.

(5) Parameters related to Optional Functions (including 2 Output specification)

- In case the data address of a parameter of an optional function which is not added is designated, an abnormal response code "0," "C" (30H, 43H) "Specification/option error" is sent back in response to both a read command (R) and a write command(W).
 When the read only data address portion is designated for reading, however, (0000H) data or a initial value is sent back.

(6) Parameters Not Shown on Front Display due to Certain Specifications of Operation or Setting

- Even parameters which are not shown on the front display (not used) due to certain specifications of operation or setting can be read and written through communication.

(7) Use of Write Command

- To use a write command, the parameter of the LCD Screen Group 1-2 Operation has to be changed from LOCAL to COMM. As this change from LOCAL to COMM is not possible by means of front key operation, the following command should be transmitted for any change:

(In the case of Add ▶01, CTRL ▶STX_ETX_CR, BCC ▶Add)

Write command format

STX	0	1	1	W	0	1	8	C	0	,	0	0	0	1	ETX	E	7	CR
02H	30H	31H	31H	57H	30H	31H	38H	43H	30H	2CH	30H	30H	30H	31H	03H	45H	37H	0DH

When the above command is transmitted and a normal response is received, the COM LED lamp on the front panel lights and the change, i.e., Operation ▶ COMM is accomplished.

Note: The example shown as a supplementary explanation of A List of Parameters describes communication carried out with the following settings:

Control code: STX_ETX_CR

Machine address: 01

Subaddress: 1

Check sum: Add

Data address (hex)	Parameter	Setting range	R/W
0100	PV value	Within measuring range	R
0101	Execution SV value	Within set value limiter	R
0102	OUT1	-5.0 ~ 105.0%	R
0103	OUT2	-5.0 ~ 105.0%	R
0104	EXE_FLG	Operation flag (See detailed explanation below.)	R
0105	EV_FLG	Event output flag (See detailed explanation below.)	R
0106	Execution SV No.	0 (SVNo.1) ~ 10 (REM)	R
0107	Execution PID No.	0 (PIDNo.1) ~ 9 (PIDNo.10)	R
0108	REM value	Within set value limiter	R
0109	CT Current	HB current value (current while output is ON) 0.0 ~ 33.0A or 0.0 ~ 55.0A	R
010A	CT Current	HL current value (current while output is OFF) 0.0 ~ 33.0A or 0.0 ~ 55.0A	R
010B	DI_FLG	DI input state flag (See detailed explanation below.)	R

- In the case of R.T.D. input and the measuring range is Range No. 09 (0.000 ~ 50.000), PV, SV and REM data will be 1/10 of displayed data (rounded to the nearest whole number).

- Example) When a PV value and an execution SV value are read (PV value=14.50°C Execution SV value=20.00°C)

The following read command format is transmitted.

```
|STX| 0 | 1 | 1 | R | 0 | 1 | 0 | 0 | 1 | ETX | D | B | CR |
|02H| 30H| 31H| 31H| 52H| 30H| 31H| 30H| 30H| 31H| 03H| 44H| 42H| 0DH|
```

The following normal response command is sent back in response.

```
|STX| 0 | 1 | 1 | R | 0 | 0 | , | 0 | 5 | A | A | 0 | 7 | D | 0 | ETX | 3 | 7 | CR |
|02H| 30H| 31H| 31H| 52H| 30H| 30H| 2CH| 30H| 35H| 41H| 41H| 30H| 37H| 44H| 30H| 03H| 33H| 37H| 0DH|
```

- ```
Sc_HH Cc_HH b---- c---- REM_HH HB_HH = 7FFFH
```
- ```
Sc_LL Cc_LL REM_LL HB_LL = 8000H
```
- Data on operation flag, event flag and DI input state flag:

Details of EXE_FLG, EV_FLG and DI_FLG are shown below.

(While out of operation Bit=0, While in operation Bit=1)

```

D15 D14 D13 D12 D11 D10 D9 D8 D7 D6 D5 D4 D3 D2 D1 D0
EXE_FLG: 0 0 0 0 0 0 0 0 COM STOP RMP ESV 0 REM STBY MAN AT
EV_FLG: 0 0 0 0 0 0 0 0 DO5 DO4 DO3 DO2 DO1 EV3 EV2 EV1
DI_FLG: 0 0 0 0 0 0 0 0 0 0 0 0 DI4 DI3 DI2 DI1

```

Example: When EV_FLG is read while EV1, EV3 and DO4 is in operation, the following read command is sent back in response.

```

EV_FLG :
  D15, D14, D13, D12      D11, D10, D9, D8      D7, D6, D5, D4      D3, D2, D1, D0
  0 0 0 0                0 0 0 0                0 1 0 0                0 1 0 1
  0H                      0H                      4H                      5H

```

```
|STX| 0 | 1 | 1 | R | 0 | 0 | , | 0 | 0 | 4 | 5 | ETX | 3 | E | CR |
|02H| 30H| 31H| 31H| 52H| 30H| 30H| 2CH| 30H| 30H| 34H| 35H| 03H| 33H| 45H| 0DH|
```

- CT current display ----, HB current value while output is OFF, HL current value while output is ON = 7FFE H

Data address (hex)	Parameter	Setting range	R/W
0110	Unit	0: °C 1: °F 2: % 3: K 4: NONE	R
0111	Range	0 ~ 16: Thermo couple 17 ~ 18: Thermo couple, Kelvin 0 ~ 15: R.T.D. 0 ~ 6: Voltage mV 0 ~ 6: Voltage V 3 ~ 4: Current mA See 8-1 "The Table of Measuring Ranges".	R
0112	CJ Comp Pt Type	0: INTER (Thermocouple) 1: EXTER (Thermocouple) 0: Pt100 (R.T.D.) 1: JPt100 (R.T.D.)	R
0113	PV D. P.	0: XXXXX 1: XXXX.X 2: XXX.XX 3: XX.XXX 4: X.XXXX	R
0114	PV Sc_L	Linear input: -19999 ~ 26000 Unit	R
0115	PV Sc_H	On R.T.D. or thermocouple input: Measuring range is displayed.	R
0116	Figur	0: YES 1: NO	R
0117	USGN	0: When a measuring range other than the following has been selected. 1: When measuring range 9 (Pt100/JPt100 0.000 ~ 50.000) has been selected.	R

Data address (hex)	Parameter	Setting range	R/W
0180	Execution SV No.	0 (SVNo.1) ~ 10 (REM)	W
0181	Execution SV No. (Q)	0 (SVNo.1) ~ 10 (REM) Quick change, though.	W
0182	OUT1	-5.0 ~ 105.0% (Setting possible only in MANUAL operation)	W
0183	OUT2		W
0184	Auto Tuning	0: STOP 1: EXEC	W
0185	Control A/M	0: AUTO 1: MANUAL	W
0186	Control Exe	0: EXEC 1: STANBY	W
0187	REM	0: Not in operation 1: In operation	W
0188	Reserve		W
0189	Reserve		W
018A	Reserve		W
018B	Ramping Run	0: RUN 1: STOP	W
018C	Operation	0: LOCAL 1: COMM	W
018D	COMDIR_FLG	COMDIR flag (See 8-2 "COMDIR.")	W

- What is quick change? ...SV No. can be changed without ramping even when RAMP Down or RAMP Up is set.
- Details of COMDIR_FLG are as follows:
(Not in operation → Bit=0, In operation → Bit=1)

COMDIR_FLG : D15 D14 D13 D12 D11 D10 D9 D8 D7 D6 D5 D4 D3 D2 D1 D0
 0 0 0 0 0 0 0 0 D05 D04 D03 D02 D01 EV3 EV2 EV1

Data address (hex)	Parameter	Setting range	R/W
0200	PV value (the most significant digit)	Within measuring range	R
0201	PV value (the least significant digit)		
0202	Execution SV value (the most significant digit)	Within set value limiter	R
0203	Execution SV value (the least significant digit)		
0204	REM value (the most significant digit)	Within set value limiter	R
0205	REM value (the least significant digit)		

- Data is long (4 bytes/2 words) data. Therefore, the following are required when reading is designated:

- (1) Lead data addresses should be even data (0200, 0202, 0204).
- (2) The number of data should be (1, 3, or 5). The actual number of data is 2, 4, or 6.

- Example) To designate a PV value to be read: (PV value=-21.63°C)

The following read command format is transmitted.

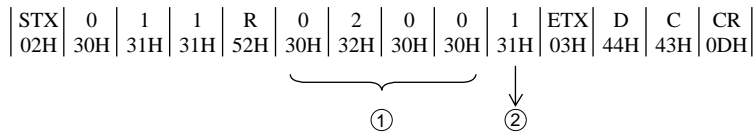

- ① Lead data address (even number)
- ② The number of data (an even number as the actual number of data is 2)

The following normal response format is sent back in response.

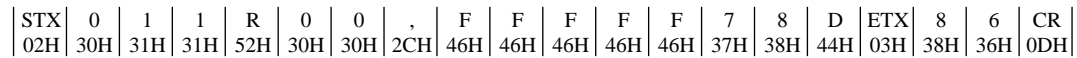

- Sc_HH cL_HH b---- c---- REM_HH = 7FFFFFFFH
- Sc_LL cLLL REM_LL = 80000000H

Data Addr. (Hex)	Parameter	Setting range	R/W
0300	SV No.1 SV value	Within set value limiter	R/W
0301	SV No.2 SV value	Within set value limiter	R/W
0302	SV No.3 SV value	Within set value limiter	R/W
0303	SV No.4 SV value	Within set value limiter	R/W
0304	SV No.5 SV value	Within set value limiter	R/W
0305	SV No.6 SV value	Within set value limiter	R/W
0306	SV No.7 SV value	Within set value limiter	R/W
0307	SV No.8 SV value	Within set value limiter	R/W
0308	SV No.9 SV value	Within set value limiter	R/W
0309	SV No.10 SV value	Within set value limiter	R/W
030A	SV Limt_L	Within measuring range (but SV Limt_L<SV Limt_H is required)	R/W
030B	SV Limt_H		R/W
030C	RAMP Up	0 ~ 9999	R/W
030D	RAMP Down	0 ~ 9999	R/W
030E	RAMP Unit	0:Unit/Sec 1:Unit/Min	R/W
030F	RAMP Rate	0: ×1 1: ×0.1	R/W
0310	SV Select	0:KEY 1:EXT	R/W
0311	Reserve		R/W
0312	Reserve		R/W
0313	Reserve		R/W
0314	REM Sc_L	Within measuring range (When REM Mode=RSV) 0.00 ~ 100.00% (When REM Mode=CTRL) but REM Sc_L≠REM Sc_H is required.	R/W
0315	REM Sc_H		R/W
0316	REM Bias	-9999 ~ 9999 Unit	R/W
0317	REM Filt	0 ~ 300	R/W
0318	REM Trak	0:NO 1:YES	R/W
0319	REM PID	0(PIDNo.1) ~ 9(PIDNo.10)	R/W
031A	REM Mode	0:RSV 1:CTRL	R/W
031B	REM P.B	0.0 ~ 999.9%	R/W
031C	REM Time	0 ~ 9999	R/W

- Example) When SVNo.1 SV value=-20.00°C (-20.00 → -2000 → F830) is to be written:

The following write commamd format is transmitted.

STX	0	1	1	W	0	3	0	0	1	,	F	8	3	0	ETX	E	E	CR
02H	30H	31H	31H	57H	30H	33H	30H	30H	31H	2CH	46H	38H	33H	30H	03H	45H	45H	0DH

The following normal response format is sent back in response.

STX	0	1	1	W	0	0	ETX	4	E	CR
02H	30H	31H	31H	57H	30H	30H	03H	34H	45H	0DH

Data Addr. (Hex)	Parameter	PID No.	Setting range	R/W
0400	P ₁	} PID No.1	0.0 ~ 999.9% (0.0=OFF)	R/W
0401	I ₁		0 ~ 6000 Sec (0=OFF)	R/W
0402	D ₁		0 ~ 3600 Sec (0=OFF)	R/W
0403	MR		-50.0 ~ 50.0%	R/W
0404	DF ₁		1 ~ 9999 Unit	R/W
0405	1_0 ₁ Lmt_L		-5.0 ~ 104.9%	R/W
0406	1_0 ₁ Lmt_H		-4.9 ~ 105.0%	R/W
0407	SF	Common	0.00 ~ 1.00	R/W
0408	P ₁	} PID No.2	The same as above	R/W
0409	I ₁			R/W
040A	D ₁			R/W
040B	MR			R/W
040C	DF ₁			R/W
040D	2_0 ₁ Lmt_L			R/W
040E	2_0 ₁ Lmt_H			R/W
040F	Reserve			R/W
0410	P ₁	} PID No.3	The same as above	R/W
0411	I ₁			R/W
0412	D ₁			R/W
0413	MR			R/W
0414	DF ₁			R/W
0415	3_0 ₁ Lmt_L			R/W
0416	3_0 ₁ Lmt_H			R/W
0417	Reserve			R/W
0418	P ₁	} PID No.4	The same as above	R/W
0419	I ₁			R/W
041A	D ₁			R/W
041B	MR			R/W
041C	DF ₁			R/W
041D	4_0 ₁ Lmt_L			R/W
041E	4_0 ₁ Lmt_H			R/W
041F	Reserve			R/W
0420	P ₁	} PID No.5	The same as above	R/W
0421	I ₁			R/W
0422	D ₁			R/W
0423	MR			R/W
0424	DF ₁			R/W
0425	5_0 ₁ Lmt_L			R/W
0426	5_0 ₁ Lmt_H			R/W
0427	Reserve			R/W

Data Addr. (Hex)	Parameter	PID No.	Setting range	R/W
0428	P ₁	} PID No.6	0.0 ~ 999.9% (0.0=OFF)	R/W
0429	I ₁		0 ~ 6000 Sec (0=OFF)	R/W
042A	D ₁		0 ~ 3600 Sec (0=OFF)	R/W
042B	MR		-50.0 ~ 50.0%	R/W
042C	DF ₁		1 ~ 9999 Unit	R/W
042D	6_0 ₁ Lmt_L		-5.0 ~ 104.9%	R/W
042E	6_0 ₁ Lmt_H		-4.9 ~ 105.0%	R/W
042F	Reserve			R/W
0430	P ₁	} PID No.7	The same as above	R/W
0431	I ₁			R/W
0432	D ₁			R/W
0433	MR			R/W
0434	DF ₁			R/W
0435	7_0 ₁ Lmt_L			R/W
0436	7_0 ₁ Lmt_H			R/W
0437	Reserve			R/W
0438	P ₁	} PID No.8	The same as above	R/W
0439	I ₁			R/W
043A	D ₁			R/W
043B	MR			R/W
043C	DF ₁			R/W
043D	8_0 ₁ Lmt_L			R/W
043E	8_0 ₁ Lmt_H			R/W
043F	Reserve			R/W
0440	P ₁	} PID No.9	The same as above	R/W
0441	I ₁			R/W
0442	D ₁			R/W
0443	MR			R/W
0444	DF ₁			R/W
0445	9_0 ₁ Lmt_L			R/W
0446	9_0 ₁ Lmt_H			R/W
0447	Reserve			R/W
0448	P ₁	} PID No.10	The same as above	R/W
0449	I ₁			R/W
044A	D ₁			R/W
044B	MR			R/W
044C	DF ₁			R/W
044D	10_0 ₁ Lmt_L			R/W
044E	10_0 ₁ Lmt_H			R/W
044F	Reserve			R/W

- Example) When PID No.6 P₁=5.6 (5.6 → 56 → 0038H) is to be written:

Write command format

|STX| 0 | 1 | 1 | W | 0 | 4 | 2 | 8 | 0 | , | 0 | 0 | 3 | 8 | ETX | E | 3 | CR |
|02H| 30H| 31H| 31H| 57H| 30H| 34H| 32H| 38H| 30H| 2CH| 30H| 30H| 33H| 38H| 03H| 45H| 33H| 0DH|

Normal response format

|STX| 0 | 1 | 1 | W | 0 | 0 | ETX | 4 | E | CR |
|02H| 30H| 31H| 31H| 57H| 30H| 30H| 03H| 34H| 45H| 0DH|

Data Addr. (Hex)	Parameter	PID No.	Setting range	R/W
0460	P ₂	} PID No.1	0.0 ~ 999.9% (0.0=OFF)	R/W
0461	I ₂		0 ~ 6000 Sec (0=OFF)	R/W
0462	D ₂		0 ~ 3600 Sec (0=OFF)	R/W
0463	DB		-20000 ~ 20000 Unit	R/W
0464	DF ₂		1 ~ 9999 Unit	R/W
0465	1_0 ₂ Lmt_L		-5.0 ~ 104.9%	R/W
0466	1_0 ₂ Lmt_H		-4.9 ~ 105.0%	R/W
0467	Reserve			R/W
0468	P ₂	} PID No.2	The same as above	R/W
0469	I ₂			R/W
046A	D ₂			R/W
046B	DB			R/W
046C	DF ₂			R/W
046D	2_0 ₂ Lmt_L			R/W
046E	2_0 ₂ Lmt_H			R/W
046F	Reserve			R/W
0470	P ₂	} PID No.3	The same as above	R/W
0471	I ₂			R/W
0472	D ₂			R/W
0473	DB			R/W
0474	DF ₂			R/W
0475	3_0 ₂ Lmt_L			R/W
0476	3_0 ₂ Lmt_H			R/W
0477	Reserve			R/W
0478	P ₂	} PID No.4	The same as above	R/W
0479	I ₂			R/W
047A	D ₂			R/W
047B	DB			R/W
047C	DF ₂			R/W
047D	4_0 ₂ Lmt_L			R/W
047E	4_0 ₂ Lmt_H			R/W
047F	Reserve			R/W
0480	P ₂	} PID No.5	The same as above	R/W
0481	I ₂			R/W
0482	D ₂			R/W
0483	DB			R/W
0484	DF ₂			R/W
0485	5_0 ₂ Lmt_L			R/W
0486	5_0 ₂ Lmt_H			R/W
0487	Reserve			R/W

Data Addr. (Hex)	Parameter	PID No.	Setting range	R/W
0488	P ₂	} PID No.6	0.0 ~ 999.9% (0.0=OFF)	R/W
0489	I ₂		0 ~ 6000 Sec (0=OFF)	R/W
048A	D ₂		0 ~ 3600 Sec (0=OFF)	R/W
048B	DB		-20000 ~ 20000 Unit	R/W
048C	DF ₂		1 ~ 9999 Unit	R/W
048D	6_0 ₂ Lmt_L		-5.0 ~ 104.9%	R/W
048E	6_0 ₂ Lmt_H		-4.9 ~ 105.0%	R/W
048F	Reserve			R/W
0490	P ₂	} PID No.7	The same as above	R/W
0491	I ₂			R/W
0492	D ₂			R/W
0493	DB			R/W
0494	DF ₂			R/W
0495	7_0 ₂ Lmt_L			R/W
0496	7_0 ₂ Lmt_H			R/W
0497	Reserve			R/W
0498	P ₂	} PID No.8	The same as above	R/W
0499	I ₂			R/W
049A	D ₂			R/W
049B	DB			R/W
049C	DF ₂			R/W
049D	8_0 ₂ Lmt_L			R/W
049E	8_0 ₂ Lmt_H			R/W
049F	Reserve			R/W
04A0	P ₂	} PID No.9	The same as above	R/W
04A1	I ₂			R/W
04A2	D ₂			R/W
04A3	DB			R/W
04A4	DF ₂			R/W
04A5	9_0 ₂ Lmt_L			R/W
04A6	9_0 ₂ Lmt_H			R/W
04A7	Reserve			R/W
04A8	P ₂	} PID No.10	The same as above	R/W
04A9	I ₂			R/W
04AA	D ₂			R/W
04AB	DB			R/W
04AC	DF ₂			R/W
04AD	10_0 ₂ Lmt_L			R/W
04AE	10_0 ₂ Lmt_H			R/W
04AF	Reserve			R/W

- Example) When PID No.6 P₂, I₂ is to be read: (P₂=8.5%, I₂=150s)

Read command format

STX	0	1	1	R	0	4	8	8	1	ETX	E	E	CR
02H	30H	31H	31H	52H	30H	34H	38H	38H	31H	03H	45H	45H	0DH

Normal response format

STX	0	1	1	R	0	0	,	0	0	5	5	0	0	9	6	ETX	0	E	CR
02H	30H	31H	31H	52H	30H	30H	2CH	30H	30H	35H	35H	30H	30H	39H	36H	03H	30H	45H	0DH

Data Addr. (Hex)	Parameter	Setting range	R/W
04C0	Zone 1	Within measuring range	R/W
04C1	Zone 2	"	R/W
04C2	Zone 3	"	R/W
04C3	Zone 4	"	R/W
04C4	Zone 5	"	R/W
04C5	Zone 6	"	R/W
04C6	Zone 7	"	R/W
04C7	Zone 8	"	R/W
04C8	Zone 9	"	R/W
04C9	Zone 10	"	R/W
04CA	Zone HYS	0 ~ 10000 Unit	R/W
04CB	Zone PID	0:Signal 1:Zone	R/W

Data Addr. (Hex)	Parameter	Event/DO No.	Setting range	R/W
0500	Mode	Event 1	0 :DEV High 1 :DEV Low 2 :DEV Outside 3 :DEV Inside 4 :PV High 5 :PV Low 6 :SV High 7 :SV Low 8 :Auto Tuning 9 :Manual 10 :Remote 11 :Run 12 :Standby 13 :Scale Over 14 :PV Scale Over 15 :REM Scale Over 16 :Direct 17 :HBA (With HB option) 18 :HLA (With HB option)	R/W
0501	Set Point		DEV High → 0 ~ 25000 Unit DEV Low → -25000 ~ 0 Unit DEV Outside → 0 ~ 25000 Unit DEV Inside → 0 ~ 25000 Unit PV High → Within measuring range PV Low → Within measuring range SV High → Within measuring range SV Low → Within measuring range	R/W
0502	Diffrentl		1 ~ 9999 Unit	R/W
0503	Inhibit		0:OFF 1:ON	R/W
0504	Delay		1 ~ 9999 Sec	R/W
0505	Charact		0:Open 1:Close	R/W
0506	Reserve		R/W	
0507	Reserve		R/W	
0508	Mode	Event 2	The same as above	R/W
0509	Set Point			R/W
050A	Diffrentl			R/W
050B	Inhibit			R/W
050C	Delay			R/W
050D	Charact			R/W
050E	Reserve		R/W	
050F	Reserve		R/W	

Data Addr. (Hex)	Parameter	Event/DO No.	Setting range	R/W
0510	Mode	Event 3	0 :DEV High 1 :DEV Low 2 :DEV Outside 3 :DEV Inside 4 :PV High 5 :PV Low 6 :SV High 7 :SV Low 8 :Auto Tuning 9 :Manual 10 :Remote 11 :Run 12 :Standby 13 :Scale Over 14 :PV Scale Over 15 :REM Scale Over 16 :Direct 17 :HBA (With HB Option) 18 :HLA (With HB Option)	R/W
0511	Set Point		DEV High → 0 ~ 25000 Unit DEV Low → -25000 ~ 0 Unit DEV Outside → 0 ~ 25000 Unit DEV Inside → 0 ~ 25000 Unit PV High → Within measuring range PV Low → Within measuring range SV High → Within measuring range SV Low → Within measuring range	R/W
0512	Diffrentl		1 ~ 9999 Unit	R/W
0513	Inhibit		0:OFF 1:ON	R/W
0514	Delay		1 ~ 9999 Sec	R/W
0515	Charact		0:Open 1:Close	R/W
0516	Reserve			R/W
0517	Reserve			R/W
0518	Mode	DO 1	The same as above	R/W
0519	Set Point			R/W
051A	Diffrentl			R/W
051B	Inhibit			R/W
051C	Delay			R/W
051D	Charact			R/W
051E	Reserve			R/W
051F	Reserve			R/W
0520	Mode	DO 2	The same as above	R/W
0521	Set Point			R/W
0522	Diffrentl			R/W
0523	Inhibit			R/W
0524	Delay			R/W
0525	Charact			R/W
0526	Reserve			R/W
0527	Reserve			R/W
0528	Mode	DO 3	The same as above	R/W
0529	Set Point			R/W
052A	Diffrentl			R/W
052B	Inhibit			R/W
052C	Delay			R/W
052D	Charact			R/W
052E	Reserve			R/W
052F	Reserve			R/W

Data Addr. (Hex)	Parameter	Event/DO No.	Setting range	R/W
0530	Mode	DO 4	0 :DEV High 1 :DEV Low 2 :DEV Outside 3 :DEV Inside 4 :PV High 5 :PV Low 6 :SV High 7 :SV Low 8 :Auto Tuning 9 :Manual 10 :Remote 11 :Run 12 :Standby 13 :Scale Over 14 :PV Scale Over 15 :REM Scale Over 16 :Direct 17 :HBA (With HB Option) 18 :HLA (With HB Option)	R/W
0531	Set Point		DEV High → 0 ~ 25000 Unit DEV Low → -25000 ~ 0 Unit DEV Outside → 0 ~ 25000 Unit DEV Inside → 0 ~ 25000 Unit PV High → Within measuring range PV Low → Within measuring range SV High → Within measuring range SV Low → Within measuring range	R/W
0532	Diffrentl		1 ~ 9999 Unit	R/W
0533	Inhibit		0:OFF 1:ON	R/W
0534	Delay		1 ~ 9999 Sec	R/W
0535	Charact		0:Open 1:Close	R/W
0536	Reserve			R/W
0537	Reserve			R/W
0538	Mode	DO 5	The same as above	R/W
0539	Set Point			R/W
053A	Diffrentl			R/W
053B	Inhibit			R/W
053C	Delay			R/W
053D	Charact			R/W
053E	Reserve			R/W
053F	Reserve			R/W

- Example) When DO4 Mode is to be read: (Mode=Direct)

Read command format

```
|STX| 0 | 1 | 1 | R | 0 | 5 | 3 | 0 | 0 | ETX | E | 1 | CR |
|02H| 30H| 31H| 31H| 52H| 30H| 35H| 33H| 30H| 30H| 03H| 45H| 31H| 0DH|
```

Normal response format

```
|STX| 0 | 1 | 1 | R | 0 | 0 | , | 0 | 0 | 1 | 0 | ETX | 3 | 6 | CR |
|02H| 30H| 31H| 31H| 52H| 30H| 30H| 2CH| 30H| 30H| 31H| 30H| 03H| 33H| 36H| 0DH|
```

Data Addr. (Hex)	Parameter	Setting range	R/W
0580	DI1	0:Nop 1:Manual 2:Remote 3:Auto Tune 4:Standby 5:Dir Act 6:Stop 7:Direct	R/W
0581	DI2	The same as above	R/W
0582	DI3	The same as above	R/W
0583	DI4	The same as above	R/W

Data Addr. (Hex)	Parameter	Setting range	R/W
0590	HBA Curr	0.0 ~ 30.0 A or 0.0 ~ 50.0A (0.0=OFF)	R/W
0591	HLA Curr	0.0 ~ 30.0 A or 0.0 ~ 50.0A (0.0=OFF)	R/W
0592	HA Mode	0:LOCK 1:REAL	R/W

Data Addr. (Hex)	Parameter	Setting range	R/W
05A0	Ao1 Mode	0:PV 1:SV 2:DEV 3:OUT1 4:OUT2	R/W
05A1	Ao1 Sc_L	PV, SV → Within measuring range DEV → -100.0 ~ 100.0% OU1, OUT2 → 0.0 ~ 100.0% but Ao1 Sc L _Ao1 Sc H is required.	R/W
05A2	Ao1 Sc_H		R/W
05A3	Reserve		R/W
05A4	Ao2 Mode	The same as above	R/W
05A5	Ao2 Sc_L		R/W
05A6	Ao2 Sc_H		R/W
05A7	Reserve		R/W

Data Addr. (Hex)	Parameter	Setting range	R/W
05B0	MEM	0:EEP 1:RAM	R/W

Data Addr. (Hex)	Parameter	Setting range	R/W
0600	Out Actn	0:Rev Act. 1:Dir Act.	R/W
0601	Out1 Cyc	1 ~ 200 Sec	R/W
0602	Err Out1	-0.5 ~ 105.0%	R/W
0603	Reserve		R/W
0604	Out2 Cyc	1 ~ 200 Sec	R/W
0605	Err Out2	-0.5 ~ 105.0%	R/W

Data Addr. (Hex)	Parameter	Setting range	R/W
0610	AT Point	1 ~ 10000 Unit	R/W
0611	Key Lock	0:OFF 1:LOCK1 2:LOCK2 3:LOCK3	R/W
0612	Disp Ret	0.10 ~ 120 Sec (0=OFF)	R/W
0613	Mode	One output type → 0:MODE 0 2:MODE 2 Two output type → 0:MODE 0 1:MODE 1 2:MODE 2 3:MODE 3	R/W

Data Addr. (Hex)	Parameter	Setting range	R/W
0701	PV Bias	-9999 ~ 9999 Unit	R/W
0702	PV Filt	0 ~ 300	R/W

- Example) When PV Bias=-10.0°C (-10.0 → 100 → FF9CH) is to be written:

Write command format

STX	0	1	1	W	0	7	0	1	0	,	F	F	9	C	ETX	1	A	CR
02H	30H	31H	31H	57H	30H	37H	30H	31H	30H	2CH	46H	46H	39H	43H	03H	31H	41H	0DH

Normal response format

STX	0	1	1	W	0	0	ETX	4	E	CR
02H	30H	31H	31H	57H	30H	30H	03H	34H	45H	0DH

7. SR25 Compatible Protocol

7-1 Communication Procedure

Communication is carried out block by block and the communication right is passed over between the host computer side and the controller side alternately for transmission of one block at a time.

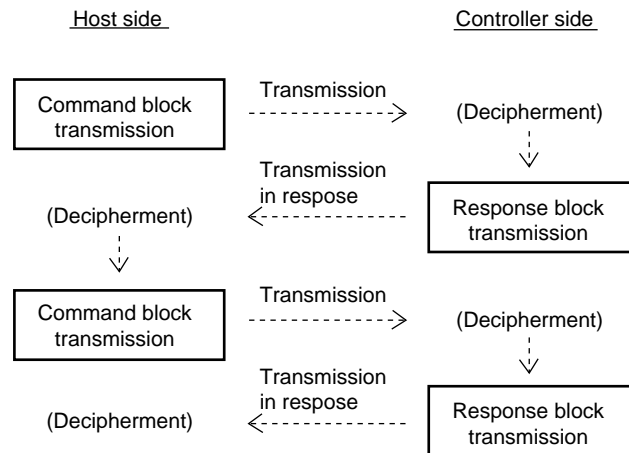

7-2 Control Codes

The following control codes are used in the command block and the response block:

Command block	
Control codes	ASCII Code
STX	02H
ETX	03H
EOT	04H
ENQ	05H

Response block	
Control codes	ASCII Code
ACK	06H
NAK	15H

7-3 Establishment and Abandonment of Data Link

In the SR25 compatible protocol, when a read command or a write command is received, data cannot be processed or transmitted in response unless a data link is established. Make sure to establish a data link before sending a command.

(1) Establishment of Data Link

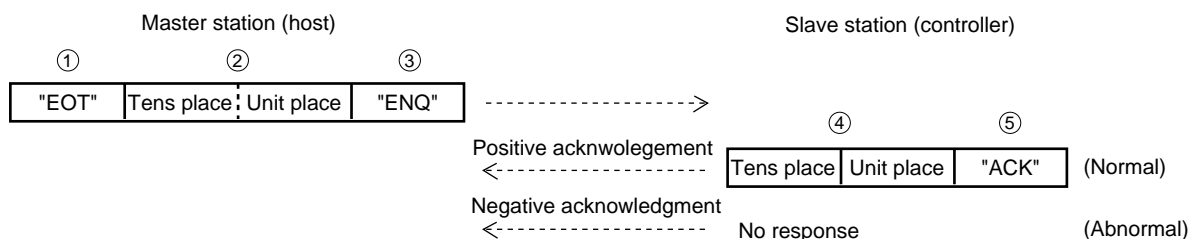

① : [Transmission termination character] ----- "EOT" (04H)

Abandonment of a data link is indicated, that is, a controller to which a data link has been established is linked off by the transmission termination character.

② : [Address (Machine No.)] -- 2 digits

The 2-digit address data (0 ~ 99) is divided to the tens digit and the units digit and each is expressed in an ASCII code.

Example: In the case of Machine No.10



③ : [Enquiry character] ----- "ENQ" (05H)

This requests an acknowledgment of data link establishment from a slave station.

④ : [Address (Machine No.)] -- 2 digits

In case the controller corresponding to the address in the command block transmitted in response is linked normally, 2-digit address code data (0 ~ 99) is divided to the tens digit and the units digit and each is expressed in an ASCII code.

⑤ : [Positive acknowledgment character] ----- "ACK" (06H)

This indicates a positive acknowledgment to the transmitter side.

- In the event there is no controller having the designated address No. or in the case of abnormal reception, there will be no response from controller.

(2) Abandonment of Data Link

Master station (host)

Slave station (controller)

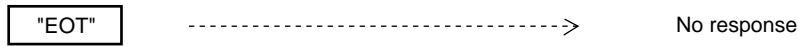

- A controller to which a data link has been established is linked off when EOT is transmitted.

7-4 Communication Format

(1) Read Command Format

Read command is to read data, status and the like of a controller.

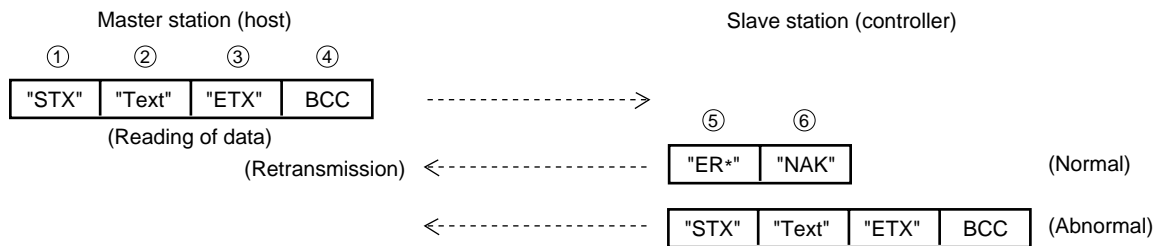

① : [Start character] ----- "STX" (02H)

Indicates the start of a block.

② : [Text] ----- An aggregate of a command and data

Expressed in accordance with each command format.

③ : [End character] ----- "ETX" (03H)

Indicates the termination of the text.

④ : [BCC check] ----- Expresses BCC check data in one digit.

A check sum is employed as a check code (BCC). The range covered by BCC is from the character immediately after STX to ETX. ASCII data of the respective bytes in the covered range are added up, ignoring the carry of the most significant bit of ASCII data. In case the length of data is 8 bits, the resultant value of this addition is BCC check data. If the data length is 7 bits, however, AND operation of the resultant value of this addition and 7FH brings about BCC check data.

Example) BCC operation of read command (DS) of the basic screen group

$$\begin{array}{ccccccc}
 \text{"STX"} & + & \text{"DS"} & + & \text{"ETX"} & + & \text{BCC} \\
 (02\text{H}) & & (44\text{H}) & (53\text{H}) & (03\text{H}) & & \uparrow \\
 & & \underbrace{\hspace{10em}} & & & & \\
 & & & & 44\text{H} + 53\text{H} + 03\text{H} = 9\text{AH} \text{ (8Bits)} & & \\
 & & & & \{ 9\text{AH} \& 7\text{FH} = 1\text{AH} \text{ (7Bits)} \} & &
 \end{array}$$

⑤ : [Error code] ----- "ER*" (*:1 ~ 4)

An error code is expressed in three digits. There are the following types of errors:

"ER1" (format error) - Text file structure is abnormal.

"ER2" (command error) - Invalid command has been used.

"ER3" (data error) - Invalid data has been tried to be established.

"ER4" (framing error) - Error of parity, length of bits, etc.

⑥ : [Negative acknowledgment character] ----- "NAK" (15H)

Indicates a negative response to the transmitter side.

(2) Write Command Format

A write command is to set (change) data of a controller, an execution key and the like.

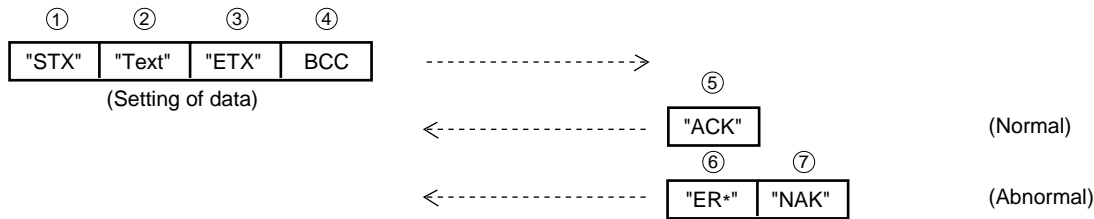

①: [Start character] ----- "STX" (02H)

Indicates the start of a block.

②: [Text] ----- An aggregate of a command and data

Expressed in accordance with each command format.

For details, see explanation in the following paragraphs.

③: [End character] ----- "ETX" (03H)

Indicates the termination of the text.

④: [BCC check] ----- Expresses BCC check data in one digit.

The method is the same as in the case of read commands.

⑤: [Positive acknowledgment character] ----- "ACK"

Indicates a positive response to the transmitter side.

⑥: [Error code] ----- "ER*" (*:1 ~ 4)

An error code is expressed in three digits. The types of errors are the same as in the case of read commands.

⑦: [Negative acknowledgment character] ----- "NAK" (15H)

Indicates a negative response to the transmitter side.

(3) Time Out and Others

- If, after receiving STX, reception of data (ETX to BCC) does not terminate within the following lengths of time, it is taken as time out and the controller waits for another command (a new STX). Therefore, a longer time than the following should be set in case the host side sets a value for time out.

Communication rate	Length of time of time out
1200, 2400 BPS	2 seconds
4800, 9600, 19200 BPS	1 seconds

- In the event NAK is received more than three times continuously, it is taken as NAK time out and another command (a new STX) is awaited. A command should be sent out again.
- If no command is received for more than three minutes after receiving the last data, it becomes time out and the data link automatically turns off. A data link should be established again.

(4) Text Format for Read Command

The following is the text format when the host side transmits a read command:

A)

Command

 Example: DS

B)

Command	Pn
---------	----

 Example: SV01

␣ (space) should not be inserted after the command.

(5) Text Format for Write Command

The following is the text format when the host side transmits a write command:

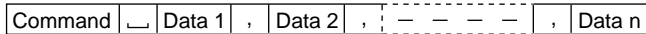

Example SV┐01, + 100.0

Nevertheless, data should be omitted as follows: (In the case of three data)

- Data after data 1 (data 2, data 3) can be omitted by using ";".

The following cases are text format errors, though.



- Data 2 is omitted by using ",".

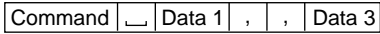

- Data 1 (by ",") and Data 3 (by ";") are omitted.



Nonetheless, the following cases are taken as text format errors.

- Such characters as "," and ";" are added after the last data is predetermined.

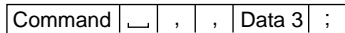

- There is no data after "┐" (space).

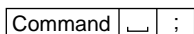

- The last is "," and the number of data is insufficient.



- The number of "," (commas) is larger than the predetermined number of data.

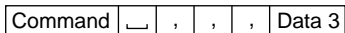

- There is another difference from the basic format.

7-5 Communication Mode (CM Command)

There are two communication modes; transmission of the CM┐* (*=L or C) makes it possible to move to the other mode.

① Local (LOCAL) Mode [COM lamp on front panel goes out]

Data is set by front key operation. Only a read command can be used.

Two methods are usable to move to the local mode.

- It is done by transmitting the CM┐L command.
- It is done by operating the front key. (The change is made by means of the parameter of the LCD Screen Group 1-2 Operation.)

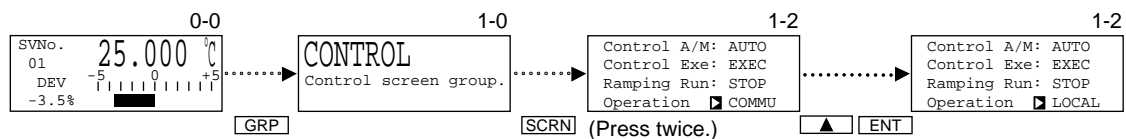

② Communication (COMM) Mode [COM lamp on front panel lights]

Data is set through communication. Both read/write commands can be used. To move to the COMM mode is done by transmitting the CM┐C command.

7-6 Commands

Where the communication protocol mode of SR253 is the "SR25 Mode," the basic commands and parameters are the same as in the case of SR25 but some are different due to units and the numbers of data.

Commands for SR253 are added or created for those which the commands for SR25 are insufficient to express.

Commands:

Commands common to SR25 and SR253.....The forms of parameter values of SR25 and SR253 are the same.

SR25-Substitution commands.....Can read and write in the forms of SR25 parameter values.

Additional commands for SR253.....Can read and write in the forms of SR253 parameter values.

Note: If you use the SR253 communication function newly, you are advised to use the additional commands for SR253 instead of the SR25-substitution commands.

7-7 A List of Commands

- Remarks columns show the following:

R: Read only

W: Write only

R/W: For both Read and Write

- Codes used in parameter columns:

S: Signs (+, -)

X: Numerical value or decimal point

N: Numerical value or alphabet

(1) Commands common to SR25 and SR253

Item	Command	SR253 Parameter		SR25 Parameter		Format	Remarks
Monitor	DS	P1 P2 P3 P4 P5 P6	PV value Execution SVNo. SV value Control A/M OUT1 OUT2	P1 P2 P3 P4 P5 P6	PV value Execution SVNo. SV value Auto/Man OUT1 OUT2	SXXXXXX NN SXXXXXX A/M SNNN.N SNNN.N	R
Auto/Manual	AM	P1 P2 P3	Control A/M OUT1 OUT2	P1 P2 P3	Auto/Man OUT1 OUT2	A/M SNNN.N SNNN.N	W
Execution SVNo	SN	P1 P2	Execution SVNo. Q	P1 P2	Execution SVNo. Q	NN Q	W
SV value	SV	P1 P2 P3 P1 P2	Type 1 Execution No. Execution SV value Target SV value Type 2 SVNo. SV vaule	P1 P2 P3 P1 P2	Type 1 No. SV SVn Type 2 No. SVn	NN SXXXXXX SXXXXXX NN SXXXXXX	R/W
Ramping value	RP	P1 P2	RAMP UP UAMP DOWN	P1 P2	UP DOWN	XXXXXX XXXXXX	R/W
Output limit	OL	P1 P2 P3 P4 P5	No. *_0_1 Lmt_L *_0_1 Lmt_H *_0_2 Lmt_L *_0_2 Lmt_H *=Designation No. (1 ~ 10)	P1 P2 P3 P4 P5	No. OUT1 L OUT1 H OUT2 L OUT2 H	NN SNNN SNNN SNNN SNNN	R/W

Item	Command	SR253 Parameter		SR25 Parameter		Format	Remarks
Condition	CD	P1	Auto Tuning	P1	AT	E/S	R
		P2	SV Select	P2	SV SEL	K/E	
		P3	Operation	P3	COM MODE	L/C	
		P4	Ramping Run	P4	RMP STS	N/S/R	
		P5	Control Exe	P5	CNTL STS	S/C	
Auto Tuning	AT	P1	Auto Tuning	P1	AT	E/S	W
SV selection	SS	P1	SV Select	P1	SS	K/E	W
Communication mode	CM	P1	Operation	P1	OP	L/C	W
Ramp control	RM	P1	Ramping Run	P1	RAMPING	N/S/R	W
Standby	SB	P1	Control Exe	P1	CONTROL	S/C	W
Output	RO	P1	Out1 Cyc	P1	CC1	NNN	R/W
		P2	Out2 Cyc	P2	CC2	NNN	
		P3	None	P3	OUT1 PRE	Fixed data "+000"	
		P4	Err Out1	P4	ERR OUT1	SNNN	
		P5	Err Out2	P5	ERR OUT2	SNNN	
Input	IN	P1	PV Bial	P1	PV BIAS	SXXXXX	R/W
		P2	REM Bias	P2	RSV BIAS	SXXXXX	
		P3	PV Filt	P3	PV FILT	NNN	
		P4	REM Filt	P4	RSV FILT	NNN	
		P5	None	P5	PV LO	Fixed Data "-010"	
		P6	None	P6	PV HI	Fixed Data "+110"	
		P7	None	P7	RSV LO	Fixed Data "-010"	
		P8	None	P8	RSV HI	Fixed Data "+110"	
DI allocation	DI	P1	DI1	P1	DI1	N	R/W
		P2	DI2	P2	DI2	N	
		P3	DI3	P3	DI3	N	
		P4	DI4	P4	DI4	N	
Ramp	RD	P1	RAMP Unit	P1	UNIT	S/M	R/W
		P2	RAMP Rate	P2	RATE	N	
Mode	MD	P1	MODE	P1	MODE	N	R/W
		P2	Out Actn	P2	ACTION	D/R	
		P3	REM Trck	P3	TRACK	T/U	
		P4	CJ Comp	P4	CJ	I/E	
		P5	Disp ret	P5	RET	Y/N	
		P6	Disp ret	P6	TIME	NNN	
Transmission output	TX	P1	Ao1 Mode	P1	TX1 KIND	N	R/W
		P2	Ao2 Mode	P2	TX2 KIND	N	
		P3	Ao1 Sc_L	P3	TX1 0%	SXXXXX	
		P4	Ao1 Sc_H	P4	TX1 100%	SXXXXX	
		P5	Ao2 Sc_L	P5	TX2 0%	SXXXXX	
		P6	Ao2 Sc_H	P6	TX2 100%	SXXXXX	

Item	Command	SR253 Parameter		SR25 Parameter		Format	Remarks
Communication	CC	P1 P2 P3	Add BPS DATA	P1 P2 P3	No. BPS FRAME	NN N N	R
System configuration	SY	P1 P2 P3 P4 P5 P6 P7	OUT1 TYPE OUT2 TYPE Ao1 TYPE Ao2 TYPE COMM REM ISO REM TYPE	P1 P2 P3 P4 P5 P6 P7	OUT1 TYPE OUT2 TYPE TX1 TYPE TX2 TYPE COMM RSV ISO RSV TYPE	N N N N N I/N N	R
Event/DO Condition	EO	P1 P2 P3 P4 P5	EV1 EV2 EV3 DO1 DO2	P1 P2 P3 P4 P5	EVENT1 N EVENT2 N EVENT3 N DO1 N DO2 N	N N N N N	R

(2) Additional commands for SR253

Item	Command	SR253 Parameter	Format	Remarks
Limit of setting	SL	P1:SV Limt_L P2:SV Limit_H P3:AT Point	SXXXXXX SXXXXXX XXXXXXX	R/W
Remote scaling	RS	P1:REM Mode P2:REM Sc_L P3:REM Sc_H P4:REM Trak P5:REM P.B P6:REM Time	N SXXXXXX SXXXXXX N NN.N NNN	R/W
PID (Output 1)	PN	P1:No. P2:P ₁ P3:I ₁ P4:D ₁ P5:DF ₁ P6:Zone P7:MR	NN NNN.N NNNN NNNN NNNN XXXXXX SXXXXXX SNN.N	R/W
PID (Output 2)	PW	P1:No. P2:P ₂ P3:I ₂ P4:D ₂ P5:DF ₂ P6:DB	NN NNN.N NNNN NNNN NNNN XXXXXX SXXXXXX	R/W
PID (Zone)	PZ	P1:Zone HYS P2:Zone PID P3:REM PID P4:SF	XXXXXXX N NN N.NN	R/W
Event	EV	P1:No. P2:Mode P3:Set Point P4:Diffrentl P5:Delay P6:Inhibit P7:Charact	N NN SXXXXXX XXXXXX NNNN N N	R/W

Item	Command	SR253 Parameter	Format	Remarks
Heater break alarm	HB	P1:CT Current P2:HBA Curr P3:HLA Curr P4:HA Mode	SNN.N SNN.N SNN.N N	R/W
Range	RR	P1:Unit P2:Figur P3:Pt Type P4:Range P5:PV D.P. P6:PV Sc_L P7:PV Sc_H	N N N NN N SXXXXX SXXXXX	R
Event output	ER	P1:EV1 P2:EV2 P3:EV3 P4:DO1 P5:DO2 P6:DO3 P7:DO4 P8:DO5	N N N N N N N N	R
DIR setting	DR	P1:EV1 P2:EV2 P3:EV3 P4:DO1 P5:DO2 P6:DO3 P7:DO4 P8:DO5	N N N N N N N N	W
Key lock	KR	P1:Key lock P2:MEM	N N	R/W

(3) SR25-substitution Commands

Item	Command	SR253 Parameter		SR25 Parameter		Format	Remarks
Control parameter	CP	P1	No.	P1	No.	NN	R/W
		P2	P ₁	P2	P	NNN.N	
		P3	I ₁ /MR	P3	I/R	NNNN/NN.N	
		P4	D ₁ /DF ₁	P4	D/H1	NNNN/N.N	
		P5	P ₂	P5	K2	NN.N	
		P6	DF ₂	P6	H2	N.N	
		P7	DB	P7	DB	SNN.N	
EVENT/DO	ED	P1	No.	P1	No.	N	R/W
		P2	Mode	P2	KIND	N	
		P3	Mode	P3	MODE	N	
		P4	Set Point	P4	VALUE	SXXXXX	
		P5	Diffmtl	P5	HYS	N.N	
		P6	Inhibit	P6	ST-BY	N/S	
		P7	Delay	P7	DT	NNNN	

Item	Command	SR253 Parameter		SR25 Parameter		Format	Remarks
Scaling	SC	P1	PV D.P.	P1	D.P.	N	R/W
		P2	SV Limt_L /PV Sc_L	P2	SVL/PVL	SXXXXX	
		P3	SV Limt_H /PV Sc_H	P3	SVH/PVH	SXXXXX	
		P4	REM Sc_L	P4	RSL	SXXXXX	
		P5	REM Sc_H	P5	RSH	SXXXXX	
Key Lock	KL	P1	Key Lock	P1	KEY LOCK1	NN	R
		P2	Key Lock	P2	KEY LOCK2	NN	
Range	RG	P1	Unit	P1	UNIT	N	R
		P2	Pt Type	P2	RTD TYPE	I/O	
		P3	Range No.	P3	RANGE No.	NN	

7-8 Details of Common Formats

(1) Scaling Data (Data related to measuring range)

For SR25, this is 6-digit data (SXXXXX, including a sign and decimal point). For SR253, only data exceeding 10000 counts (unit) is in 7 digits (SXXXXXX, including a sign and decimal point). Accordingly, in case the range is the same as that of SR25, it corresponds to the communication specification of SR25.

(2) Numerical data

a. Without sign

N : "1", "2"
 NN : "02", "15"
 NNN : "012", "123"
 NNNN : "0012", "1234"
 NN.N : "01.2", "12.3"
 NNN.N : "012.3", "123.4"

b. With signs

SNNN : "+123", "-123"
 SNN.N : "+12.3", "-12.3"
 SNNN.N : "+100.0", "-005.0"

S:Signs +/-

.:Point

N:Numeral

(3) Abnormalities of PV Value and SV Value

+ side over-range = +HH---

- side over-range = -LL---

+ side unindicatable value = +DH---

- side unindicatable value = -DL---

Heater break alarm with R.T.D.input

 = B.B---

 = B.C---

(4) SV No, PID No.

No.1 ~ 10 is expressed by 01 ~ 10 and REM No. by 00.

7-9 Details of Commands Common to SR25 and SR253

(1) Monitor (DS)

P1: [PV value] Execution PV value
 P2: [SVNo.] Execution SV No.
 P3: [SV value] The same format as PV value of P1
 P4: [AUTO/MAN] A:Auto M:Manual
 P5: [OUT1] Control output 1
 P6: [OUT2] Control output 2

Note 1: P6 is invalid in the case of an instrument of the one output type.

(2) Auto/Manual (AM)

P1: [A/M] M can be omitted in manual operation.
 P2: [OUT1] Setting possible in manual operation and when switching to manual operation.
 P3: [OUT2] Setting possible in manual operation and when switching to Manual (in the case of an instrument of two output type).

Switching to Auto :AM_A

Switching to Manual: AM_M,+012.3,+045.6

During execution of ON/OFF control, however: 100% output when more than +050.0 is written, and 0% output when less than +050.0 is written.

Note 1: P3 is invalid in the case of an instrument of one output type.

(3) Execution SV No. (SN)

P1: [SVNo.] Execution SV No.

P2: [Q] Quick change when Q is designated.

SN┘02: Selection of SV No.2

SN┘05,Q: Quick change to SV No.5 (Switch to SV No.5 without ramping)

(4) SV Value (SV)

This can be read by an SV command in the following two methods of command transmission and data are sent back to them in different formats from each other.

Command transmission method at the time of reading

SV (without parameter) → Type 1

SV01 (SV No. added) → Type 2

(Type 1)

P1: [SVNo.] Present SV No.

P2: [Execution SV value] Refer to SV value of monitor.

P3: [SV value of P1] Refer to SV value of monitor.

(Type 2)

P1:[SVNo.] When omitted, it is considered identical to the execution SV No. When this parameter and the comma "," following it are omitted, it is also considered identical to the execution SV No.

P2:[SV value of P1] If SV No. is REM, writing is not possible.

If SV No. is REM and REM Mode=CTRL, the format is SNNN.NN when read.

(5) Ramping Value (RP)

P1:[UP] When read in the case of RAMP UP=OFF, OFF┘┘ is returned. Writing 0 sets RAMP UP=OFF. 00000, 000.0, 00.00, 0.000, .0000 depending on designated data type.

P2:[DOWN] When read with RAMP DOWN=OFF, OFF┘┘ is returned. Writing 0 sets RAMP DOWN=OFF. 00000, 000.0, 00.00, 0.000, .0000 depending on designated data type.

(6) Output Limit (OL)

P1:[SVNo.]

When omitted, it is regarded as identical to the execution SV No.

P2:[OUT1 L]

P3:[OUT1 H]

P4:[OUT2 L]

P5:[OUT2 H]

As output limit values of SR253 are to one decimal place (-5.0 ~ 105.0), they should be rounded to units so that data have no decimal point (-5 ~ 105).

Note: P4 and P5 are invalid in the case of instrument of one output type.

(7) Condition (CD)

P1:[AT] S: In suspension E: In execution

P2:[SV SEL] K: Selection by keys in Local mode and through communication in Communication mode. E: External switch

P3:[COM MODE] L: Local mode C: Communication mode

P4:[RMP STS] N: Non-ramping S: In temporary suspension R: Ramping

P5:[CNTL STS] C: Control S: Standby

(8) Auto Tuning (AT)

P1: [AT] S: Instruction to suspension E: Instruction to execute

(9) Selection of SV (SS)

P1: [SS] K: Selection by keys in Local mode and through communication in Communication mode.
E: External switch

(10) Communication Mode (CM)

P1: [OP] L: Local mode C: Communication mode

(11) Ramp Control (RM)

P1: [RAMPING] N: Non-ramping S: In temporary suspension R: Ramping

(12) Standby (SB)

P1: [CONTROL] C: Control S: Standby

(13) Output (RO)

P1:[CC1]	}	When read in the case of linear input, fixed "000" data is returned.
P2:[CC2]		
P3:[OUT1 PRE]		
P4:[ERR OUT1]		Output 1 error output
P5:[ERR OUT2]		Output 2 error output

Note 1: In the case of a one output type instrument, P2 and P5 are invalid.

(14) Input (IN)

P1:[PV BIAS]	PV bias value	
P2:[RSV BIAS]	When REM Mode=CTRL, the SNNN.NN format should be used.	
P3:[PV FILT]	PV filter value	
P4:[RSV FILT]	RSV filter value	
P5:[PV LO]	When reading is designated, fixed to "-010"	}
P6:[PV HI]	When reading is designated, fixed to "+110"	
P7:[RSV LO]	When reading is designated, fixed to "-010"	
P8:[RSV HI]	When reading is designated, fixed to "+110"	

Since SR253 does not have these parameters, when reading is designated, the respective fixed data are returned. In writing, they should be omitted by using ",", " or ";".

(15) DI Allocation (DI)

P1:[DI1]	}					
P2:[DI2]		0: Nop	1: Manual	2: Remote	3: Auto Tune	4: Standby
P3:[DI3]		5: Dir Act	6: Stop	7: Direct		
P4:[DI4]						

(16) Ramp (RD)

P1:[Unit]	S: Unit/Sec	M: Unit/Min
P2:[RATE]	0: ×1	1: ×0.1

(17) Mode (MD)

P1:[MODE]	0: MODE 0	
	1: MODE1	
	2: MODE2	
	3: MODE3	
P2:[ACTION]	R: Reverse operation	D: Direct operation
P3:[TRACK]	T: Tracking operation	U: Non-tracking
P4:[CJ]	Omitted except in the case of TC input	
	I: Internal	E: External
P5:[RET]	Y: Valid	N: Invalid
P6:[TIME]	When RET=N is written, it is initialized to Time=60. Nevertheless, SR253 screen shows Disp ret=OFF and no time value is displayed.	

(18) Analog Output (TX)

P1:[TX1 KIND]	}	0: PV
P2:[TX2 KIND]		1: SV
		2: DEV
		3: SV
		4: OUT1
	5: OUT2	
P3:[TX1 0%]	}	When P1 is SV or PV, the format of SV or PV is used.
P4:[TX1 100%]		If P1 is DEV, OUT1 or OUT2, the format, SNNN.N is used.
P5:[TX2 0%]	}	When P2 is SV or PV, the format of SV or PV is used.
P6:[TX2 100%]		If P2 is DEV, OUT1 or OUT2, the format, SNNN.N is used.

Note 1: In the case of only one analog output, P2, P5 and P6 are invalid.

(19) Communication (CC)

P1:[No.]	Machine No. (00 ~ 99)				
P2:[BPS]	0: 1200	1: 2400	2: 4800	3: 9800	4: 19200
P3:[FRAME]	0: 7E1	1: 7E2	2: 7N1	3: 7N2	
	4: 8E1	5: 8E2	6: 8N1	7: 8N2	

(20) System Configuration (SY)

P1:[OUT1 TYPE]	}	0: None	1: Relay	2: SSR	3: 4 ~ 20mA	5: 0 ~ 10V
P2:[OUT2 TYPE]						
P3:[TX1 TYPE]	}	0: None	1: 0 ~ 10mV	3: 4 ~ 20mA	5: 0 ~ 10V	
P4:[TX2 TYPE]						
P5:[COMM]		0:None	1: RS-232C	2: RS-422A	3: RS-485	
P6:[RSV ISO]		N: Not isolated	I: Isolated			
P7:[RSV TYPE]		0: 0 ~ 10V	1: 1 ~ 5V	3: 4 ~ 20mA		

(21) EVENT/DO Condition (EO)

P1:[EVENT1]	}	0: Output OFF	1: Output ON
P2:[EVENT2]			
P3:[EVENT3]			
P4:[DO1]			
P5:[DO2]			

7-10 Details of Added Commands for SR253

(1) Setting Limit (SL)

P1:[SV Limt_L]	}	The formats of SV and PV values are used.
P2:[SV Limt_H]		
P3:[AT Point]		

(2) Remote Scaling (RS)

P1:[REM Mode]	0: RSV	1: CTRL
P2:[REM Sc_L]	}	In the case of REM Mode=RSV, the formats of SV and PV values are used.
P3:[REM Sc_H]		
P4:[REM Trak]	0: NO	1: YES
P5:[REM P.B]	When read in the case of REM P.B=OFF, 000.0 is returned. When 000.0 is written, REM P.B=OFF is set.	
P6:[REM Time]	When read in the case of REM Time=OFF, 0000 is returned. When 0000 is written, REM Time=OFF is set.	

(3) PID "in relation to Output 1" (PN)

P1:[No.]	No.1 ~ 10 are expressed by 01 ~ 10 and REMNo. is expressed by 00.
P2:[P ₁]	When read in the case of P ₁ =OFF, 000.0 is returned. When 000.0 is written, P ₁ =OFF is set.
P3:[I ₁]	When read in the case of I ₁ =OFF, 0000 is returned. When 0000 is written, I ₁ =OFF is set.
P4:[D ₁]	When read in the case of D ₁ =OFF, 0000 is returned. When 0000 is written, D ₁ =OFF is set.
P5:[DF ₁]	In the case of P ₁ ≠OFF, writing is not possible. When read in the case of P ₁ ≠OFF, it is omitted by ", ".
P6:[Zone]	The formats of SV and PV values are used.
P7:[MR]	Manual reset.

(4) PID "in relation to Output 2" (PW)

(This command is valid only when the instrument is of the two output type.)

P1:[No.]	No.1 ~ 10 are expressed by 01 ~ 10 and REMNo. is expressed by 00.
P2:[P ₂]	When read in the case of P ₂ =OFF, 000.0 is returned. When 000.0 is written, P ₂ =OFF is set.
P3:[I ₂]	When read in the case of I ₂ =OFF, 0000 is returned. When 0000 is written, I ₂ =OFF is set.
P4:[D ₂]	When read in the case of D ₂ =OFF, 0000 is returned. When 0000 is written, D ₂ =OFF is set.
P5:[DF ₂]	In the case of P ₂ ≠OFF, writing is not possible. When read in the case of P ₂ ≠OFF, it is omitted by " , ".
P6:[DB]	The formats of SV and PV values are used.

(5) PID "in relation to Zone" (PZ)

P1:[Zone HYS]	Zone hysteresis
P2:[Zone PID]	0: Single 1: Zone
P3:[REM PID]	No.1 ~ 10 are expressed by 01 ~ 10.
P4:[SF]	Set value function

(6) Event (EV)

To read by EV commands, they should be input as follows:

EV* (*=1 ~ 8)
 1: EV1 2: EV2 3: EV3 4: DO1 5: DO2 6: DO3 7: DO4 8: DO5

P1:[No.] 1: EV1 2: EV2 3: EV3 4: DO1 5: DO2 6: DO3 7: DO4 8: DO5
 P2:[Mode] 01: DEV High 11: Remote
 02: DEV Low 12: RUN
 03: DEV Outside 13: Stanby
 04: DEV Inside 14: Scale Over
 05: PV High 15: PV Scale Over
 06: PV Low 16: REM Scale Over
 07: SV High 17: Direct
 08: SV Low 18: HBA
 09: Auto Tuning 19: HLA
 10: Manual

Note 1: When a mode is set to 09 ~ 19, subsequent parameters (P3 ~ P7) are omitted.

P3:[Set Point] The formats of SV and PV values are used.
 P4:[Diffrentl] Action hysteresis
 P5:[Delay] When read in the case of Delay=OFF, 0000 is returned.
 When 0000 is written, Delay=OFF is set.
 P6:[Inhibit] 0: OFF 1: ON
 P7:[Charact] 0: OPEN 1: CLOSE

(7) Heter Break Alarm (HB)

P1:[CT Current] Since this paramater cannot be written, omit it by "," when written.
 If reading is designated when scale-over arises in the heater current value, the following data are returned.
 Scale-over of higher limit value: +HH--
 Scale-over of lower limit value : -LL--
 P2:[HBA Curr] Set value of heater break alarm
 P3:[HLA Curr] Set value of heater loop alarm
 P4:[HA Mode] 0: LOCK 1: REAL

(8) Range (RR)

P1:[Unit] 0: °C 1: °F 2: % 3: K 4: BNK
 P2:[Figur] 0: YES 1: NO
 P3:[Pt Type] 0: Pt100 1: JPt100
 P4:[Range] See 8-1 "A List of Measuring Ranges."
 P5:[PV D.P.] 0: XXXXX
 1: XXXX.X
 2: XXX.XX
 3: XX.XXX
 4: X.XXXX

P6:[PV Sc_L] }
 P7:[PV SC_H] } The formats of SV and PV values are used.

(9) Event Output Condition (ER)

P1:[EV1]
 P2:[EV2]
 P3:[EV3]
 P4:[DO1]
 P5:[DO2]
 P6:[DO3]
 P7:[DO4]
 P8:[DO5]

} 0: Operation is OFF 1: Operation is ON

(10)DIR Setting (DR)

For details of COMDIR, refer to 8-2 "COMDIR."

P1:[EV1]	}	0: Operation is OFF 1: Operation is ON
P2:[EV2]		
P3:[EV3]		
P4:[DO1]		
P5:[DO2]		
P6:[DO3]		
P7:[DO4]		
P8:[DO5]		

(11)Key Lock (KR)

P1:[Key Lock]	0: OFF 1: Except SV and CONTROL 2: Except SV 3: All
P2:[MEM]	0: EEP 1: RAM

7-11 Details of SR25 Substitution Commands

(1) Control Parameters (CP)

P1: [PIDNo.]	When omitted, it is considered identical to Execution PIDNo.									
P2: [P]	When read in the case of P ₁ =OFF, 000.0 is returned. When 000.0 is written, P ₁ =OFF is set.									
P3: [I/R]	For I (Format: NNNN) (In the case of P ₁ =OFF, neither read nor write is possible.) <ul style="list-style-type: none"> When NNNN is written, data is written in I. (Writing in I precludes MR=0.0.) When read in the case of I≠OFF, the value of I is returned. For R (Format: NN.N) (In the case of P ₁ =OFF, neither read nor write is possible.) <ul style="list-style-type: none"> When NN.N is written, I=OFF is set and data is written in R. When read in the case of I=OFF, the value of R is returned. Since MR of SR253 is in ±50% range, R=MR+50.0. The setting range should be 0.0 ~ 99.9%, the same as in the case of SR25 although 100.0 should be 99.9.									
P4: [D/H1]	For D (Format: NNNN) (In the case of P ₁ =OFF, neither read nor write is possible.) <ul style="list-style-type: none"> When read in the case of D=OFF, OFF <u> </u> is returned. When OFF is written, D=OFF is set. For H1 (Format: N.N) (In the case of P ₁ ≠OFF, neither read nor write is possible.) Since DF ₁ of SR253 is 1 ~ 9999Unit, it should be converted to data including the first decimal place (0.1 ~ 9.9%) by integer operation (including rounding to the nearest whole number). $H1=(DF_1*1000)/span \text{ value}$ If data exceeds the setting range when read or written, however, it is limited to be within the range.									
P5: [K2]	When read in the case of P ₂ =OFF, 00.0 is returned. When 00.0 is written, P ₂ =OFF is set. Since P ₂ of SR253 is 0.1 ~ 999.9%, it should be converted to data of 0.1 ~ 10.0 by integer operation (including rounding to the nearest whole number). $K2=P_1/P_2$ If data exceeds the setting range when read or written, however, it is limited to be within the range. Before carrying out the operation, the following conditions are given priority. <ul style="list-style-type: none"> To a read command, computation is made on the assumption of: <table> <tr> <td>P₂ = OFF</td> <td>→</td> <td>K2 = 0</td> </tr> <tr> <td>P₁ = OFF</td> <td>→</td> <td>P₁ = 10.0%</td> </tr> </table> To a write command, <table> <tr> <td>K2 = 0</td> <td>→</td> <td>P₂ = OFF</td> </tr> </table> 	P ₂ = OFF	→	K2 = 0	P ₁ = OFF	→	P ₁ = 10.0%	K2 = 0	→	P ₂ = OFF
P ₂ = OFF	→	K2 = 0								
P ₁ = OFF	→	P ₁ = 10.0%								
K2 = 0	→	P ₂ = OFF								

P6:[H2] In the case of P₂≠OFF, neither read nor write is possible.
 Since DF₂ is 1 ~ 9999Unit, the same conversion as in H1 should be carried out to make the setting range 0.1 ~ 9.9%.

P7:[DB] Since DB of SR253 is -20000 ~ +20000Unit, the following integer operation (including rounding to the nearest whole number) should be carried out:

$$DB(SR25)= \frac{DB(SR253)}{(P1/100) \times (\text{Higher limit value of measuring range} - \text{Lower limit value of measuring range})} \times 100(\%)$$

Nevertheless, if data exceeds the setting range, it is limited to be within the range.

Before operation, the following conditions are given priority:

Computed on the assumption of P₂ = OFF → P₁ = 100%.

Computed on the assumption of P₁ = OFF → P₁ = 10.0%.

P₂ is checked first and then P₁ is checked.

Note 1: In the case of an instrument of one output type, P5, P6 and P7 are invalid.

(2) EVENT/DO (ED)

To read by using ED commands, commands should be input as follows:

EV* (*=1 ~ 8)

1: EV1 2: EV2 3: EV3 4: DO1 5: DO2 6: DO3 7: DO4 8: DO5

P1:[No.]

P2:[KIND]

P3:[MODE]

1: EV1 2: EV2 3: EV3 4: DO1 5: DO2 6: DO3 7: DO4 8: DO5

In SR253, KIND and MODE of SR25 are allowed to be set at the same time and so data conversion is carried out.

SR253	For reading		For writing	
	KIND	MODE	KIND	MODE
DEV High	0	4	0	(.) or (;)
			0	4
DEV Low	0	5	0	5
DEV Out	0	6	0	6
DEV In	0	7	0	7
PV High	1	0	1	(.) or (;)
			1	0
PV Low	1	2	1	1
			1	2
SV High	2	0	2	(.) or (;)
			2	0
SV Low	2	2	2	1
			2	2
Auto Tuning	3	(.) or (;)	3	(.) or (;)
Manual	7	(.) or (;)	7	(.) or (;)
Remote	6	(.) or (;)	6	(.) or (;)
Run	4	(.) or (;)	4	(.) or (;)
Standby	9	(.) or (;)	---	---
Scale Over	5	(.) or (;)	5	(.) or (;)
PV Scale Over	5	(.) or (;)	---	---
REM Scale Over	5	(.) or (;)	---	---
Direct	9	(.) or (;)	---	---
HBA	9	(.) or (;)	---	---
HLA	9	(.) or (;)	---	---

Note 1: Any other combination of KIND and MODE than the above is taken as an error.

Note 2: When the type of events is set to Auto Tuning ~ HLA, subsequent parameters (P4 ~ P7) are omitted.

P4: [VALUE] The formats of SV and PV values are used.

P5: [HYS] Since Diffrent1 is 1 ~ 9999Unit, it should be converted to data (0.1 ~ 9.9%) including the first decimal place by integer operation (including rounding to the nearest whole number).

$$HYS=(\text{Diffrent1} \times 1000) / \text{span value}$$

Nevertheless, if data exceeds the setting range, it is limited to be within the range.

P6: [ST-BY] N: Non-standby S: Standby

P7: [DT] When read in the case of Deley =OFF, 0000 is returned.

When 0000 is written, Deley =OFF is set.

(3) Scaling (SC)

P1:[D.P]

This parameter can be written in the case of linear input.

0: XXXXX

1: XXXX.X

2: XXX.XX

3: XX.XXX

4: X.XXXX

P2:[SVL/PVL]

In the case of linear input, reading and writing are possible against PVL and PVH. (The formats of SV and PV values are used.)

P3:[SVH/PVH]

In the case of RTD or TC input, reading and writing are possible against SVL and SVH. (The formats of SV and PV values are used.)

P4:[RSL]

P5:[RSH]

The formats of SV and PV values are used.

(4) Key Lock (KL)

P1:[KEY LOCK1]

P2:[KEY LOCK2]

SR253 Key Lock	P1 Data	P2 Data
OFF	00	00
Lock1	BD	FF
Lock2	FD	FF
Lock3	FF	FF

(5) Range (RG)

P1:[Unit]

0: °C 1: °F 2: % 3: BRK 4: K

P2:[RTD TYPE]

O: Old JIS 1: IEC/JIS

Omitted in the case of TC input or linear input.

P3:[RANGE No.]

■ Thermocouple input

RANGE NO.	Type of input	Measuring range	
		°C	°F
00	B	0 ~ 1800	0 ~ 3300
01	R	0 ~ 1700	0 ~ 3100
02	S	0 ~ 1700	0 ~ 3100
03	K	-100.0 ~ 400.0	-150 ~ 750
04	K	0 ~ 800.0	0 ~ 1500
05	K	0 ~ 1200	0 ~ 2200
06	E	0 ~ 700.0	0 ~ 1300
07	J	0 ~ 600.0	0 ~ 1100
08	T	-199.9 ~ 200.0	-300 ~ 400
09	N	0 ~ 1300	0 ~ 2300
10	PL	0 ~ 1300	0 ~ 2300
11	PR40-20	0 ~ 1800	0 ~ 3300
12	WRe5-26	0 ~ 2300	0 ~ 4200
13	U	-199.9 ~ 200.0	-300 ~ 400
14	L	0 ~ 600.0	0 ~ 1100

If the range is other than those which are shown in the table on the left, 15 is returned.

■ Linear input (current, voltage)

RANGE NO.	Voltage(mV)	Current(mA)	Voltage(V)
22	-10 ~ 10	—	-1 ~ 1
23	0 ~ 10	—	0 ~ 1
24	0 ~ 20	—	0 ~ 2
25	0 ~ 50	0 ~ 20	0 ~ 5
26	10 ~ 50	4 ~ 20	1 ~ 5
27	0 ~ 100	—	0 ~ 10

If the range is other than those which are shown in the table on the left, 28 is returned.

■ R.T.D. (Pt100/JPt100)

RANGE NO.	Type of input	Measuring range	
		°C	°F
31	Pt100/JPt100	-199.9 ~ 600.0	-300 ~ 1100
32		-100.0 ~ 100.0	-150.0 ~ 200.0
33		-100.0 ~ 300.0	-150.0 ~ 600.0
34		-40.0 ~ 60.0	-40.0 ~ 140.0
35		0.00 ~ 50.00	0 ~ 120.0
36		0 ~ 100.0	0 ~ 200.0
37		0 ~ 200.0	0 ~ 400.0
38		0 ~ 500.0	0 ~ 1000

If the range is other than those which are shown in the table on the left, 39 is returned.

8. Supplementary Explanation

8-1 Tables of Measuring Ranges

■ Thermocouple Input

SR25 compatible protocol Additional commands for SR253 RANGE	Standard protocol RANGE	Type of input	Measuring range		
			°C	°F	K
01	0	B	0.0 ~ 1800.0	0 ~ 3300	————
02	1	R	0.0 ~ 1700.0	0 ~ 3100	————
03	2	S	0.0 ~ 1700.0	0 ~ 3100	————
04	3	K	-100.0 ~ 400.0	-150.0 ~ 750.0	————
05	4	K	0.0 ~ 400.0	0.0 ~ 750.0	————
06	5	K	0.0 ~ 800.0	0.0 ~ 1500.0	————
07	6	K	0.0 ~ 1200.0	0.0 ~ 2200.0	————
08	7	K	-200.0 ~ 200.0	-300.0 ~ 400.0	————
09	8	E	0.0 ~ 700.0	0.0 ~ 1300.0	————
10	9	J	0.0 ~ 600.0	0.0 ~ 1100.0	————
11	10	T	-200.0 ~ 200.0	-300.0 ~ 400.0	————
12	11	N	0.0 ~ 1300.0	0.0 ~ 2300.0	————
13	12	PLII	0.0 ~ 1300.0	0.0 ~ 2300.0	————
14	13	PR40-20	0.0 ~ 1800.0	0 ~ 3300	————
15	14	WRe5-26	0.0 ~ 2300.0	0 ~ 4200	————
16	15	U	-200.0 ~ 200.0	-300.0 ~ 400.0	————
17	16	L	0.0 ~ 600.0	0.0 ~ 1100.0	————
18	17	K	————	————	10.0 ~ 350.0
19	18	Gold iron/ Chromel	————	————	0 ~ 350.0

■ R.T.D. Input (Pt100/JPt100)

SR25 compatible protocol Additional commands for SR253 RANGE	Standard protocol RANGE	Type of input	Measuring range	
			°C	°F
01	0	Pt100 (JPt100)	-200.0 ~ 600.0	-300.0 ~ 1100.0
			-200.0 ~ 500.0	-300.0 ~ 900.0
02	1	Pt100/JPt100 Common	-100.00 ~ 100.00	-150.0 ~ 200.0
03	2		-100.0 ~ 100.0	-150.0 ~ 200.0
04	3		-100.0 ~ 300.0	-150.0 ~ 600.0
05	4		-60.00 ~ 40.00	-80.00 ~ 100.00
06	5		-50.00 ~ 50.00	-60.00 ~ 120.00
07	6		-40.00 ~ 60.00	-40.00 ~ 140.00
08	7		-20.00 ~ 80.00	0.00 ~ 180.00
09	8		0.000 ~ 50.000	0.00 ~ 120.00
10	9		0.00 ~ 50.00	0.00 ~ 120.00
11	10		0.00 ~ 100.00	0.00 ~ 200.00
12	11		0.0 ~ 100.0	0.0 ~ 200.0
13	12		0.00 ~ 200.00	0.0 ~ 400.0
14	13		0.0 ~ 200.0	0.0 ~ 400.0
15	14		0.0 ~ 300.0	0.0 ~ 600.0
16	15	Pt100 (JPt100)	0.0 ~ 500.0	0.0 ~ 1000.0
			0.0 ~ 500.0	0.0 ~ 900.0

■ Linear Input (Current, Voltage)

SR25 compatible protocol Additional commands for SR253 RANGE	Standard protocol RANGE	Voltage (mV)	Current (mA)	Voltage (V)
01	0	-10 ~ 10	————	-1 ~ 1
02	1	0 ~ 10	————	0 ~ 1
03	2	0 ~ 20	————	0 ~ 2
04	3	0 ~ 50	0 ~ 20	0 ~ 5
05	4	10 ~ 50	4 ~ 20	1 ~ 5
06	5	0 ~ 100	————	0 ~ 10
07	6	-100 ~ 100	————	-10 ~ 10

8-2 COMDIR

EV and DO can be operated by signals through communication.

The following table shows relations between COMDIR and EV/DO:

COMDIR:	D7	D6	D5	D4	D3	D2	D1	D0
FLG:	DO5	DO4	DO3	DO2	DO1	EV3	EV2	EV1

Example) To operate EV3 by means of COMDIR signals:

- (1) Direct is allocated to EV3.
- (2) EV3 output is produced/stopped by putting D2 in operation or out of operation through communication.

Note 1: If Direct is allocated to DI3 and DI3 input is ON, DI3 remains in operation even when D2 is placed in operation/out of operation by DR commands. (Output generated by a DR command and output caused by DI input are OR output.)

Note 2: COMDIR signals are not retained in the memory. Since all bits are cleared when power is turned OFF, resetting is required after reapplying power. In the event DIR is not allocated to the EV/DO mode, EV/DO output is not generated by transmitting a COMDIR signal.

9. A Table of ASCII Codes

	b7b6b5	000	001	001	011	100	101	110	111
b4 ~ b1		0	1	2	3	4	5	6	7
0000	0	NUL	TC7 (DLE)	S P	0	@	P	`	p
0001	1	TC1 (SOH)	DC1	!	1	A	Q	a	q
0010	2	TC2 (STX)	DC2	”	2	B	R	b	r
0011	3	TC3 (ETX)	DC3	#	3	C	S	c	s
0100	4	TC4 (EOT)	DC4	\$	4	D	T	d	t
0101	5	TC5 (ENQ)	TC8 (NAK)	%	5	E	U	e	u
0110	6	TC6 (ACK)	TC9 (SYN)	&	6	F	V	f	v
0111	7	BEL	TC10 (ETB)	'	7	G	W	g	w
1000	8	FE0 (BS)	CAN	(8	H	X	h	x
1001	9	FE1 (HT)	EM)	9	I	Y	i	y
1010	A	FE2 (LF)	SUB	*	:	J	Z	j	z
1011	B	FE3 (VT)	ESC	+	;	K	[k	{
1100	C	FE4 (FF)	IS4 (FS)	,	<	L	\	l	
1101	D	FE5 (CR)	IS3 (GS)	-	=	M]	m	}
1110	E	SO	IS2 (RS)	.	>	N	^	n	~
1111	F	SI	IS1 (US)	/	?	O	_	o	DEL

Distributed in New Zealand by:

Intech INSTRUMENTS LTD

Christchurch	Auckland	www.intech.co.nz
Ph: +6433430646	098271930	sales@intech.co.nz
Fx: +6433430649	098271931	

The contents of this manual are subject to change without notice.

Temperature and Humidity Control Specialists
SHIMADEN CO., LTD.

Head Office: 2-30-10 Kitamachi, Nerima-Ku, Tokyo 179-0081 Japan
Phone: +81-3-3931-7891 Fax: +81-3-3931-3089
E-MAIL: exp-dept@shimaden.co.jp URL: <http://www.shimaden.co.jp>

PRINTED IN JAPAN