

Series **SR1 / SR3 / SR4**

# SHIMADEN DIGITAL CONTROLLER

## BASIC FEATURES

- Multi-input and multi-range performance
- Large 20mm bright display (SR3)
- Dust and splash proof front panel NEMA4X / IP66



**CE** approved    **UL** approved (except SR4)

## ORDERING INFORMATION

ITEM	CODE	SPECIFICATIONS
SERIES	SR1-	MPU-Based Auto-Tuning PID Digital Controller, DIN H48 x W48 x D111mm
	SR3-	MPU-Based Auto-Tuning PID Digital Controller, DIN H96 x W96 x D111mm
	SR4-	MPU-Based Auto-Tuning PID Digital Controller, DIN H96 x W48 x D111mm
INPUT	8	Multi input
		Thermocouple: B, R, S, K, E, J, T, N, PLII, WRe5-26 (U, L (DIN 43710)) R.T.D.: Pt100/JPt100
	6	Voltage (mV): -10~10, 0~10, 0~20, 0~50, 10~50, 0~100mV DC Voltage (V): -1~1, 0~1, 0~2, 0~5, 1~5, 0~10V DC Current (mA): 0~20mA DC:(V) 0~5V DC Current (mA): 4~20mA DC:(V) 1~5V DC (applied via enclosed 250Ω shunt resistor)
CONTROL OUTPUT	Y-	Contact 1a Contact capacity: 240V AC 2.0A/resistive load Proportional cycle: 1~120 seconds
	I-	Current 4~20mA DC Load Resistance: 600Ω max.
	P-	SSR drive voltage 12V ±1.5V DC 30mA max. Proportional cycle:1~120 seconds
	V-	Voltage 0~10V DC Load current: 2mA max.
EVENT OUTPUT	1	Event output (1a) x 2 points, Contact capacity: 240V AC 1A/resistive load
REMARKS	W	Without
	X	With (Please consult before ordering.)

## MEASURING RANGE CODES

Type of input	Code	Scaling range	
Thermocouple	B *1	01	0 ~ 1800 °C    0 ~ 3300 °F
	R	02	0 ~ 1700 °C    0 ~ 3100 °F
	S	03	0 ~ 1700 °C    0 ~ 3100 °F
	K	*3 04	-199.9 ~ 400.0 °C    -300 ~ 750 °F
		05	0.0 ~ 800.0 °C    0 ~ 1500 °F
	E	06	0 ~ 1200 °C    0 ~ 2200 °F
	J	07	0 ~ 700 °C    0 ~ 1300 °F
	T *3	08	0 ~ 600 °C    0 ~ 1100 °F
	N	*3 09	-199.9 ~ 200.0 °C    -300 ~ 400 °F
		10	0 ~ 1300 °C    0 ~ 2300 °F
	PLII *4	11	0 ~ 1300 °C    0 ~ 2300 °F
	WRe5-26*5	12	0 ~ 2300 °C    0 ~ 4200 °F
	U *2, *3	*3 13	-199.9 ~ 200.0 °C    -300 ~ 400 °F
		L *2	14
R.T.D.	Pt100	31	-200 ~ 600 °C    -300 ~ 1100 °F
		32	-100.0 ~ 100.0 °C    -150.0 ~ 200.0 °F
		33	-50.0 ~ 50.0 °C    -50.0 ~ 120.0 °F
		34	0.0 ~ 200.0 °C    0.0 ~ 400.0 °F
	JPt100	35	-200 ~ 500 °C    -300 ~ 1000 °F
		36	-100.0 ~ 100.0 °C    -150.0 ~ 200.0 °F
		37	-50.0 ~ 50.0 °C    -50.0 ~ 120.0 °F
		38	0.0 ~ 200.0 °C    0.0 ~ 400.0 °F

Type of input	Code	Scaling range
Voltage (mV)	-10 ~ 10	71
	0 ~ 10	72
	0 ~ 20	73
	0 ~ 50	74
	10 ~ 50	75
Voltage (V)	0 ~ 100	76
	-1 ~ 1	81
	0 ~ 1	82
	0 ~ 2	83
	0 ~ 5	84
	1 ~ 5	85
0 ~ 10	86	

**Note:**\*1 Thermocouple B: Accuracy guarantee not applicable Temp. below 400°C.  
 \*2 Thermocouple U, L: DIN 43710  
 \*3 Thermocouple K, T, U: Accuracy guarantee not applicable Temp. below -100.0°C ± (1.0%FS+1digit) & -100.0 ~ 0.0°C ± (0.5%FS+1digit)  
 \*4 Thermocouple PLII: Platinel  
 \*5 Thermocouple WRe5-26: ASTM988

\*Unless otherwise specified, following setting will be applied for shipment.

Input	Specification/Rating	Measuring range
Multi input	K thermocouple	0.0 ~ 800.0 C
Voltage (V)	0 ~ 10V DC	0.0 ~ 100.0

Control Output	Control Mode
Y	ON-OFF (P=OFF)
I, P, V	PID Control (P=3.0)

# SPECIFICATIONS

# Series SR1 / SR3 / SR4

## Model

SR1: 48 x 48 Digital Controller  
 SR3: 96 x 96 Digital Controller  
 SR4: 96 x 48 Digital Controller

## Display

Digital display: SR1, SR4: (PV)/4 digit 7 segments red LED (H: 11mm)  
 (SV)/4 digit 7 segments green LED (H: 9.5mm)  
 SR3: (PV)/4 digit 7 segments red LED (H: 20mm)  
 (SV)/4 digit 7 segments green LED (H: 13mm)  
 Display accuracy:  $\pm (0.3\%FS + 1 \text{ digit})$  (see "Note" in Measuring Range Codes)  
 (Excluding cold junction compensation accuracy)

Display accuracy maintaining range:  
 23°C  $\pm$  5°C

Display resolution: Depends on measuring range (0.001, 0.01, 0.1, 1)  
 Display updating cycle: 0.5 seconds  
 Action display: 5 LED lamp displays (OUT/EV1/EV2/AT/MAN)

## Setting

Setting method: By operating 4 keys ( $\nabla$ ,  $\blacktriangle$ , ENT,  $\odot$ ) (front panel)  
 Target value setting range:

Same as measuring range (within setting limiter)  
 Individual setting for higher & lower limits are possible within measuring range (Lower limit value < Higher limit value)

Setting limiter:

## Input

Type of input: Selectable from multiple (TC, Pt, mV) and voltage (V)  
 \*Current input 0-20mA DC (Voltage: 0-5V), 4-20mA DC (Voltage: 1-5V) applied via 250 $\Omega$  shunt resistor  
 Thermocouple: B, R, S, K, E, J, T, N, PL II, WR e5-26, (U, L (DIN 43710))  
 Input impedance: 500k $\Omega$  minimum  
 External resistance tolerance:

100 $\Omega$  maximum  
 Burnout function: Standard feature (up scale)  
 Cold junction compensation accuracy:

$\pm 1^\circ\text{C}$  (within 23°C  $\pm$  5°C)  
 $\pm 2^\circ\text{C}$  (ambient temperature: 5°C to 45°C)

R.T.D.: Pt100/JPt100, 3-wire type

Amperage: 0.25 mA

Lead wire tolerance: Lead wire tolerance: 5 $\Omega$  max/wire  
 (3 lead wires should have the same resistance.)

Voltage mV: -10~10, 0~10, 0~20, 0~50, 10~50, 0~100mV DC  
 (Burnout) V: Up scale at time of abnormal input  
 -1~1, 0~1, 0~2, 0~5, 1~5, 0~10V DC

Input impedance: 500k $\Omega$  minimum

Input scaling function: Scaling possible for voltage (mV, V) or current (mA) input

Scaling range: -1999~9999 counts

Span: 10~5000 counts

Decimal point: (Position) None, 0.0, 0.00, 0.000

Sampling cycle: 0.5 seconds

PV bias: -1999~2000 units

PV filter: 0~100 seconds

Isolation: Insulated between input and output (not insulated between input and system)

## Control

Control mode: Expert PID control with auto tuning function  
 Proportional band (P): OFF, 0.1~999.9% (ON-OFF action by OFF)  
 Integral time (I): OFF, 1~6000 seconds (P or PD action by OFF)  
 Derivative time (D): OFF, 1~3600 seconds (P or PI action by OFF)  
 Manual reset: -50.0~50.0% (Effective when I=OFF)  
 ON-OFF hysteresis: 1~999 units (Effective when P=OFF)  
 Proportional cycle: 1~120 seconds (for contact and SSR drive voltage output)

## Control output characteristic:

RA (reverse action characteristic)/DA (direct action characteristic) is selectable (Default setting =RA)  
 \*P=OFF by default for contact output, others: PID control

## Type of control/rating:

Contact: 1A 240V AC 2A (resistive load)  
 SSR drive voltage: 12V  $\pm$  1.5V DC (Max load current 30mA)  
 Voltage: 0~10V DC (Max load current 2mA)  
 Current: 4~20mA DC (Max load resistance 600 $\Omega$ )  
 Control output resolution: Approx. 0.5%/1200  
 Isolation: Output isolated from all

## Event output

Number of events: Total 2 points of EV1 and EV2 as standard  
 Type: Selectable from the following 8 types for EV1 and EV2:  
 No selection, Higher limit deviation, Lower limit deviation, Outside higher/lower limit deviations, Within higher/lower limit deviations, Higher limit absolute value, Lower limit absolute value, Scaleover

## Event setting range:

Absolute values: (both higher limit and lower limit): Within measuring range, Deviations: (both higher limit and lower limit): -1999~2000 units, Higher/lower limit deviations (within/outside): 0~2000 units

## Event action:

ON-OFF action  
 Hysteresis: 1~999 units  
 Standby action: Selectable from the following 4 types  
 (1) None, (2) Standby when power is applied, (3) Standby when power is applied and when SV value in execution is changed, (4) Control mode without standby action (No alarm is output at the time of abnormal input).

## Output type/rating:

Contact (1A x 2 points common)/240V AC 1A (resistive load)  
 Output updating cycle: 0.5 seconds

## Action display:

2 LED lamp displays (EV1/EV2)

## General Specifications

Data storage: Non-volatile memory (EEPROM)  
 Operating conditions: (Ambient temperature) -10~50°C  
 (Ambient humidity) 90%RH or less (no dew condensation)  
 (Altitude) 2000m from the sea level or lower  
 (Category) II, (Degree of pollution) 2

## Storage temperature:

-20~65°C

## Supply voltage:

100-240V AC  $\pm$  10% 50/60Hz

## Power consumption:

10VA 240V AC, 6VA 100V AC

## Input/noise removal ratio:

(Normal mode) 40 dB or higher (50/60 Hz)  
 (Common mode) 120 dB or higher (50/60 Hz)  
 For Voltage (V) input: 90 dB or higher (50/60 Hz)

## Applicable standards:

Safety: IEC61010 and EN61010-1  
 EMC: EN61326 (Class A: Industrial environment)  
 Insulation resistance: Input/output - power supply: 500V DC 20M $\Omega$  or above  
 Input/output - contact output: 500V DC 20M $\Omega$  or above

## Dielectric strength:

Input/output - power supply: 2300V AC 1 minute  
 Contact output - power supply: 2300V AC 1 minute

## Protective structure:

Only front panel has dust-proof and drip-proof structure  
 NEMA4X and IP66

## Material / Color of case:

PPO resin molding (equivalent to UL94V-1) / Ivory

## External dimensions:

SR1: H48 x W48 x D111 (Panel depth: 100) mm  
 SR3: H96 x W96 x D111 (Panel depth: 100) mm  
 SR4: H96 x W48 x D111 (Panel depth: 100) mm

## Mounting:

Push-in panel (one-touch mount)  
 1.0~4.0 mm

## Panel thickness:

SR1: H45 x W45 mm / Approx. 150 g  
 SR3: H92 x W92 mm / Approx. 270 g  
 SR4: H92 x W45 mm / Approx. 190 g

## External Dimensions & Panel Cutout

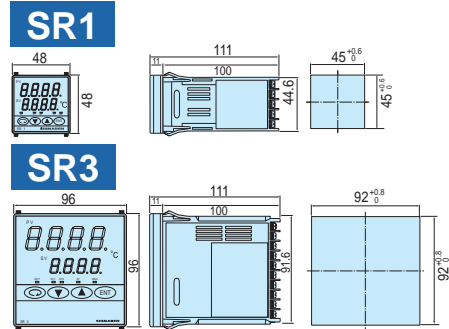

## Terminal Arrangement

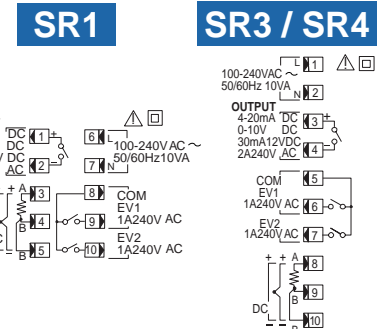

Unit: mm

## TERMINAL COVER (AVAILABLE SEPARATELY)

Material: PVC, Appearance: transparent, Thickness: 1 mm

Model	Terminal Cover (P/N)	Mounting
SR1	QCR001	One-touch mount
SR3	QCR006	One-touch mount
SR4	QCR004 (Individual Mounting)	Plus screw, B tight, M2.3 x 6 - 2 pcs.
	QCR005 (Tight-lock coupling)	Plus screw, B tight, M2.3 x 6 - 4 pcs.

- Warning** • The SR1 / SR3 / SR4 series are designed for the control of temperature, humidity and other physical values for the general industrial equipment. It is not to be used for any purpose which regulates the prevention of serious effects on human life or safety. No warranty, express or implied is valid if used without proper safety measures.
- Caution** • If the possibility of loss or damage to your system or property as a result of failure of any part of the process exists, proper safety measures must be made before the instrument is put into use as to prevent the occurrence of trouble.

(The contents of this brochure are subject to change without notice.)

Temperature and Humidity Control Specialists

# SHIMADEN CO., LTD.

Head Office: 2-30-10 Kitamachi, Nerima-Ku, Tokyo 179-0081 Japan  
 Phone: +81-3-3931-7891 Fax: +81-3-3931-3089  
 E-MAIL: exp-dept@shimaden.co.jp URL: http://www.shimaden.co.jp

Distributed in New Zealand by:

## Intech INSTRUMENTS LTD

Christchurch Auckland [www.intech.co.nz](http://www.intech.co.nz)  
 Ph: +6433430646 098271930  
 Fx: +6433430649 098271931 [sales@intech.co.nz](mailto:sales@intech.co.nz)