

°C	<b>MICROPROCESSOR-BASED</b>	<b>Series SR253</b>
%RH	<b>AUTO-TUNING PID CONTROLLERS</b>	
<b>SHIMADEN</b>		



### BASIC FEATURES

- 1 / 1000 °C display and adjustment are possible.**  
*\*Only for R.T.D. input (scale: 0.000~50.000 °C)*
- Temperature can be set on the basic screen.**
- The operability has been remarkably improved with the dialogue system introduced by the 4-digit LCD display on the front panel.**
- The front display section and operation section have been designed dust-proof and drip-proof.**  
*\*Equivalent to IEC529 Standards IP65*
- High Accuracy  $\pm 0.1\%$**
- High Sampling Cycle 0.2 sec.**
- Auto-Tuning PID/Auto-Tuning PID+PID**
- RA/DA Selectable**
- User-Selectable Inputs (Thermocouple)**
- User-Selectable Ranges**
- Programmable-Scaling (DCmV, DCmA)**
- Multi-Setting of 10 Set Values**
- User Friendly Operation (Menu Driven)**
- Universal Power Supply (100~240V AC  $\pm 10\%$ )**
- Interface RS-422A/RS-232C/RS-485**
- 96 (H) x 96 (W) x 140 (D) mm (Panel Depth: 125mm)**

- High accuracy of 0.1% and multifunctional performance meet various types of process control needs.
- SR253 Controller features multifunctional performance. Yet, with the use of the dialogue system by the 4-digit LCD display, operability has been improved to a high degree.
- A variety of functions are built in, including types of event outputs, remote setting function, and external control input. With this unit connected with the sequencer on the production line, the production line will be automated.
- With expert PID control system incorporated, a much more enhanced control operation is the result. As two-output control has become available, temperature control on the order of room temperature and control of a process involving heat generation are also available as both heating and cooling volumes are adjusted simultaneously.

**NAME & FUNCTION**

**Monitor Lamp Displays**

- STBY : It flashes with "EXECUTE" set in standby mode.
- RUN : It flashes during ramp control and remains lit for temporary stop.
- ESV : It remains lit when SV No. is selected by external contact.
- REM : It remains lit when remote SV is selected.
- COM : It remains lit when the communication function is activated.
- EV1 : It remains lit when EV1 is activated.
- EV2 : It remains lit when EV2 is activated.
- EV3 : It remains lit when EV3 is activated.
- DO1 : It remains lit when DO1 is activated.
- DO2 : It remains lit when DO2 is activated.
- DO3 : It remains lit when DO3 is activated.
- DO4 : It remains lit when DO4 is activated.
- DO5 : It remains lit when DO5 is activated.

**AT (Auto-Tuning) Lamp**

**MAN (Manual Adjustment) Lamp**

It illuminates and goes out when current or voltage is output. It illuminates with the contact or SSR drive voltage output ON.

**Process Value (PV) Display**

- Sampling cycle : 0.2sec.
- Thermocouple : Multi-input and multi-range (19 types)
- R.T.D. : Multi-range (16 types)
- Voltage : Multi-input and programmable scaling (14 types)
- Current : Multi-input and programmable scaling (2 types)

**Legend Display °C / °F Selectable**

**LCD Functional Displays**

Action mode (output value) in operation and parameter set values are displayed on the 21-character and 4-line display (back-lighted).



**Setting Key Switches**

- DISP** For returning to PV and SV screens and for moving to the initial screen of a group
- GRP** For moving from one group to another group
- SCRN** For moving from screen to screen in a group
- Rotary** For selecting on from two or more parameters
- Left Arrow** For shifting
- Down Arrow** For setting numerical values and parameters
- Up Arrow** For setting numerical values and parameters
- ENT** For registering set numerical values and items

**PID Setting group**

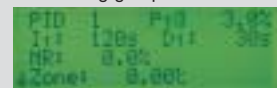

**Event / Do Setting group**

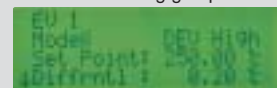

**Unit / Measuring Setting group**



**Display**

- LED display: 7-segment green LED 5 digits / height of character 14 mm  
Measured value (PV) display
- LCD display: 128 x 32 full dot matrix liquid crystal display  
(Basic display 21 digits, 4 lines with LED back light)  
Set value (SV), SV No. display and set parameter display
- LED lamp indication: Action (status) display 16 types for 1 output, 17 types for 2 outputs  
AT, MAN, STBY, RUN, ESV, REM, COM, EV1, EV2, EV3, DO1, DO2, DO3, DO4, DO5, OUT1, OUT2
- Display accuracy: TC input:  $\pm(0.1\% \text{ FS} + 1^\circ\text{C})$   
Pt input:  $\pm(0.1\% \text{ FS} + 0.1^\circ\text{C})$   
mV, mA input:  $\pm(0.1\% \text{ FS} + 1\text{digit})$
- Temperature range for maintaining accuracy:  $23^\circ\text{C} \pm 5^\circ\text{C}$
- Display resolution: Depends on measuring range and scaling (0.0001, 0.001, 0.01, 0.1, 1)
- Sampling cycle: 200 msec. (0.2 sec.)

**Setting**

- Local setting: By 8 front key switches  
Setting range: Same as measuring range  
Multi SV value setting: Setting of 10 points maximum possible  
Multi SV value setting: Selectable by front key switches or DI input (binary code)  
Higher and lower limit setting limiter: Higher / lower limit individual setting as desired within measuring range (lower limit value < higher limit value)
- Remote setting: By external analog signals  
Not insulated / standard (0~10V); Insulated / optional  
Setting accuracy:  $\pm(0.1\% \text{ FS} + 1\text{digit})$   
Setting signal: 0~10V, 1~5V DC, 4~20mA DC / Selectable from code selection table  
Sampling cycle: 3 times / sec. (200 / 400 msec.)  
Remote scaling: Possible within measuring range (inverse scaling possible)  
Remote bias:  $\pm 9999$  unit  
Remote filter: OFF, 1~300 Sampling cycle (Approx. 1 / 3 sec.)
- Local / remote switching: By front Key switch or external operation
- Direct tracking function: Remote set value switchable to local set value bumplessly
- Ramp control: Increment / Decrement control  
Setting range: 1~9999 unit / min. or sec. individual setting (0.1~999.9 unit / min. or sec. individual setting)

**Input**

- Thermocouple: B, R, S, K, E, J, T, N, PLII, PR40-20, WRe5-26, {L, U (DIN) 43710}  
Gold & iron-Chromel (multi input, multi range)  
External resistance allowable range: 100 $\Omega$  max.  
Influence of external resistance:  $1\mu\text{V} / 10\Omega$   
Input impedance: 500k $\Omega$  min.  
Burnout function: Standard feature (up scale)  
Cold junction temperature compensation: Selectable between internal cold junction temperature compensation / external cold junction temperature compensation
- Internal cold junction temperature compensation accuracy:  $\pm 1.0^\circ\text{C}$  (within range from 18 to 28 $^\circ\text{C}$ )
- R.T.D.: JIS Pt / JPt 3-wire type (multi range)  
Lead wire tolerable resistance: 5 $\Omega$  max. / wire  
Amperage: Approx. 1mA

- Voltage: -10~10, 0~10, 0~20, 0~50, 10~50, 0~100, -100~100mV DC or -1~1, 0~1, 0~2, 0~5, 1~5, 0~10, -10~10V DC (Multi input, programmable scaling)
- Input impedance: 500kΩ min.
- Current: 4~20, 0~20mA DC (Multi input, programmable scaling)
- Receiving impedance: 250Ω
- PV bias: ±9999 unit
- PV filter: OFF, 1~300 sampling cycle (0.2 sec.)
- Isolation: Insulated between input and DI input, outputs insulated from each other (Not insulated between input and system, remote input and CT input)

Control

- Control mode: In case of 1 output: Expert PID control with auto tuning function  
In case of 2 output: Expert PID + PID control with auto tuning function  
During RA-Heating / cooling action  
During DA-Heat + heat action
- Control output 1  
Multi PID: By PID No. 01~10 (10 types)  
Control output 1 proportional cycle: 1~200 sec. (in case of contact or SSR drive voltage output)
- Control output 2 (applicable only to apparatus with optional function of 2 outputs)  
Multi PID: By PID No. 01~10 (10 types)  
Control output 2 proportional cycle: 1~200 sec. (in case of contact or SSR drive voltage output)
- Control output type / rating:  
Contact output: 240V AC / 2.5A (resistive load)  
Current output: 4~20mA DC / load resistance: 600Ω max.  
SSR drive voltage: 12±1.5V DC / load current: 30mA max.  
Voltage output: 0~10V DC / load current: 2mA max.
- Output resolution: Approx. 1/8000 (with current / voltage output)
- Output accuracy: ±0.5% FS (5~100% output / within accuracy maintaining temperature range)
- Operation / output updating cycle: 200 msec.
- Multi PID: Individual PID (10 types) setting for each SV no. and Remote SV.  
Zone PID, ie., PID setting for each zone of SV values is also possible.  
Selectable between individual PID and zone PID
- Zone PID mode:  
Control output 1  
Proportional band: Off, 0.1~999.9% (OFF setting: On-Off action)  
Integral time: Off, 1~6000 sec. (OFF setting: With manual reset)  
Derivative time: Off, 1~3600 sec.  
Action hysteresis: 1~9999 unit (during On-Off action)
- Control output 2  
Proportional band: Off, 0.1~999.9% (OFF setting: On-Off action)  
Integral time: Off, 1~6000 sec.  
Derivative time: Off, 1~3600 sec.  
Action hysteresis: 1~9999 unit (during On-Off action)  
Dead band: -20000~20000 unit
- Higher / lower output limiter: Higher limit / lower limit (to be set on every individual PID)  
Setting range: -5.0~105.0% (lower limit > higher limit)
- Control output characteristics: RA / DA switchable by front key switch or external control input (DI)
- External control input: Remote input usable as external control input  
Remote mode: Remote SV input / external control input selectable  
Remote proportional coefficient: Off, 0.1~999.9%  
Remote primary delay time: Off, 1~9999 sec.
- Manual control  
Output setting range: Y, P: 0.0~100.0%, I, V: -5.0~105.0%  
Output resolution: 0.1%  
Auto / manual switch: Balanceless bumpless action (within proportional band range)  
Switching by front key switch or external control input (DI)
- Isolation: Insulated between control output and various inputs / outputs and system (not insulated between 1 output and 2 outputs)

**Event Output (Option)**

- The number of outputs: Total 3 points, from EV1 to EV3
- Output rating: Contact output 240V AC / 1.0A (resistive load)
- Setting / selection: Individual setting (individual output) / Selectable from following 19 types (output designation)

1) DEV : Higher limit	(deviation value action)	11) REM	: In remote operation	ON
2) DEV : Lower limit	(deviation value action)	12) RUN	: Ramp control in execution	ON
3) DEV : Out of range	(deviation value action)	13) STBY	: Control action not in execution	ON
4) DEV : Within range	(deviation value action)	14) SO	: Scale-over of PV and REM	ON
5) PV : Higher limit	(absolute value action)	15) PV SO	: Scale-over of PV	ON
6) PV : Lower limit	(absolute value action)	16) REM SO	: Scale-over of REM	ON
7) SV : Higher limit	(absolute value action)	17) DIR	: During direct output	ON
8) SV : Lower limit	(absolute value action)	18) HBA	: During heater break alarm output (option)	ON
9) AT : Auto turning in execution	ON	19) HLA	: During heater loop alarm output (option)	ON
10) MAN : In manual operation	ON			

DEV, PV and SV events allow the following setting:

- Hysteresis: 1~9999 unit
- Inhibit action: With / without selectable
- Action delay: Off, 1~9999 sec.
- Switching of output characteristics: Individually selectable between normal open and normal close

- Isolation: Insulated between EV outputs and various inputs and system; various outputs insulated from each other

**DI Input / DO Output (Option)**

- The number of DI inputs: Multi SV selection 4 points, control inputs 4 points (Total 8 points)
- DI input type: Exclusive use for multi SV selection (binary input)  
Selectable setting from 8 types: NOP, AT, MAN, REM, STOP, STBY, DA, DIR  
Non-voltage contact, or open collector input
- DI input rating: Non-voltage contact, or open collector input
- The number of DO outputs: 5 points from DO1 to DO5
- DO output type: Individual setting / individual output (Selectable designation from 19 types) (Details are the same as EV option)
- DO output rating: Open collector output 24V DC / 50mA max.
- Isolation: Insulated between DI input / DO output and various inputs and system; various outputs insulated from each other (not insulated between DI input and DO output)

**Heater Break Alarm (Option)**

- Alarm action: Heater amperage detected by externally attached CT (special CT provided) (single phase)  
Alarm output On upon detection of heater break while control output is On.  
Alarm output On upon detection of heater loop alarm while control output is Off.
- Setting
  - Current setting range: Off, 0.1~50.0A (Off setting: HB or HL alarm action stops)
  - Setting resolution: 0.1A
- Display
  - Amperage display: 0.0~55.0A
  - Display accuracy: 3% FS (When sine wave is 50Hz)
- Output holding: Selectable between holding mode and real mode
- Sampling cycle: 1 sec.
- Minimum time for action confirmation: 250 msec. min. (every second) both at On time and Off time
- Isolation: Insulated between CT input and DI input: various outputs insulated from each other (not insulated between sensor input and remote input and system)
- Output method: Assigned to event outputs

Analog Output (Option)

- The number of analog outputs: Maximum 2 points (individual setting / individual output)
- Analog output type: Selectable from PV, SV, DEV, OUT1 and OUT2
- Output rating: 0~10mV DC / output resistance: 10Ω  
0~10V DC / load current: 1mA max.  
4~20mA DC / load resistance: 300 max.
- Output accuracy: ±0.1% FS (of displayed value)
- Output resolution: Approx. 0.01% (1 / 10000)
- Output updating cycle: 200 msec. (0.2 sec.)
- Output scaling: Within measuring range (inverse scaling possible)
- Isolation: Insulated between analog outputs and various inputs and system; various outputs insulated from each other (analog outputs not insulated from each other)

Communication Function (Option)

- Communication type: RS-232C, RS422A and RS-485
- Communication system: Half duplex start-stop synchronization system
- Communication rate: 1200, 2400, 4800, 9600 and (19200) bps
- Data bit length: Selectable from 7 bits, 8 bits, no parity and even parity
- Communication address: 0~99
- Communication code: ASCII code
- Communication protocol: Standard protocol and SR25-conforming protocol
- Others: Selectable for control code, BCC check operating system, delay time and memory mode  
Note: When SR25-conforming protocol is being selected, control code and BCC check operating system are not selectable.
- Isolation: Insulated between communication signals and various inputs and system; various outputs insulated from each other

General Specification

- Data storage: By non-volatile memory (EEPROM)
- Operating ambient temperature / humidity range: -10~50°C / 90% RH max. (no dew condensation)
- Storing temperature: -20~+65°C
- Supply voltage: 100V-240V AC±10% (50 / 60Hz)
- Power consumption: Maximum 15 VA
- Input noise removal ratio: Normal mode: 60 dB minimum (50 / 60Hz)  
Common mode: 140 dB minimum (50 / 60Hz)
- Applicable standards: Safety: IEC1010-1 and EN61010-1  
EMC: EN55011: Class A Group 1 (EMI / emission)  
EN50082-2: 1995 (EMS / immunity)  
During EMC testing, the apparatus continues to operate at a measurement accuracy within ±2% of the range.
- Insulation resistance: Between input / output terminal and power supply terminal: 500V DC 20 MΩ minimum  
Between input / output terminal and ground terminal: 500V DC 20 MΩ minimum
- Dielectric strength: 1 min. at 2300V AC between input / output terminal and power supply terminal (Responsive current 5mA)  
1 min. at 2300V AC between power supply terminal and ground terminal (Responsive current 5mA)
- Protective structure: The front operating panel is dust-proof and drip-proof. (equivalent to IP65)
- Material of case: PPO resin molding (equivalent to UL94V-1)
- External dimensions: H96 x W96 x D138 (panel depth: 125) mm  
When terminal cover is used: (panel depth: 130) mm  
When direct type plug is used: (panel depth: 180) mm
- Mounting: Push-in panel (one-touch mount)
- Panel thickness: 1~4.5 (Panel thicker than 4.5 mm can be mounted by means of mounting metal fittings.)
- Size of mounting hole: H92 x W92
- Weight: Approx. 600g



□ Example of use:

Actions assigned from outside the instrument can be controlled when switch is connected to external input / output 24-pin plug Nos. 12 (COM), 11 (DI 1), 10 (DI 2), 9 (DI 3) and 8 (DI 4) and contact signals are applied.

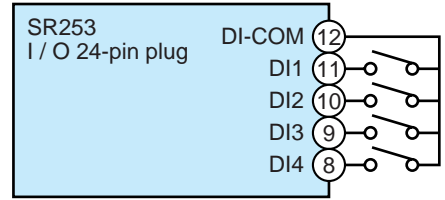

□ Selection of local SV No.:

Local SV No. can be selected by external input. In order to use this function, you have to select EXT Setting of selections / switch of multi-SV No. to light the ESV lamp in the front panel.

□ Example of use:

SV No. can be selected from outside the instrument when 24-pin plug for external input / output (an accessory to this instrument) is used and BIN code digital switch is connected to pin Nos. 12 (COM), 7 (SEL1), 6 (SEL2), 5 (SEL4) and 4 (SEL8).

For 24-pin plug and BIN code digital switch (multi-SV No. switching device), see external input / output plug accessories.

If you do not have BIN code digital switch, select SV No. by applying contact signals to 24-pin plug terminals as shown in the following table.

When SV No.5 is to be selected:  
Short across pin Nos. 12 (COM), 7 (SEL1) and 5 (SEL3).

SR253 I / O 24-pin plug	SV-COM (12)	SV-SEL1 (7)	SV-SEL2 (6)	SV-SEL4 (5)	SV-SEL8 (4)	SV No.																
						Pin No.	1	2	3	4	5	6	7	8	9	10						
						No.7 (SEL 1)	●															
						No.6 (SEL 2)		●														
						No.5 (SEL 4)				●												
						No.4 (SEL 8)																

The ● mark shows shorting between the pin No. and COM

## APPLICATION EXAMPLE

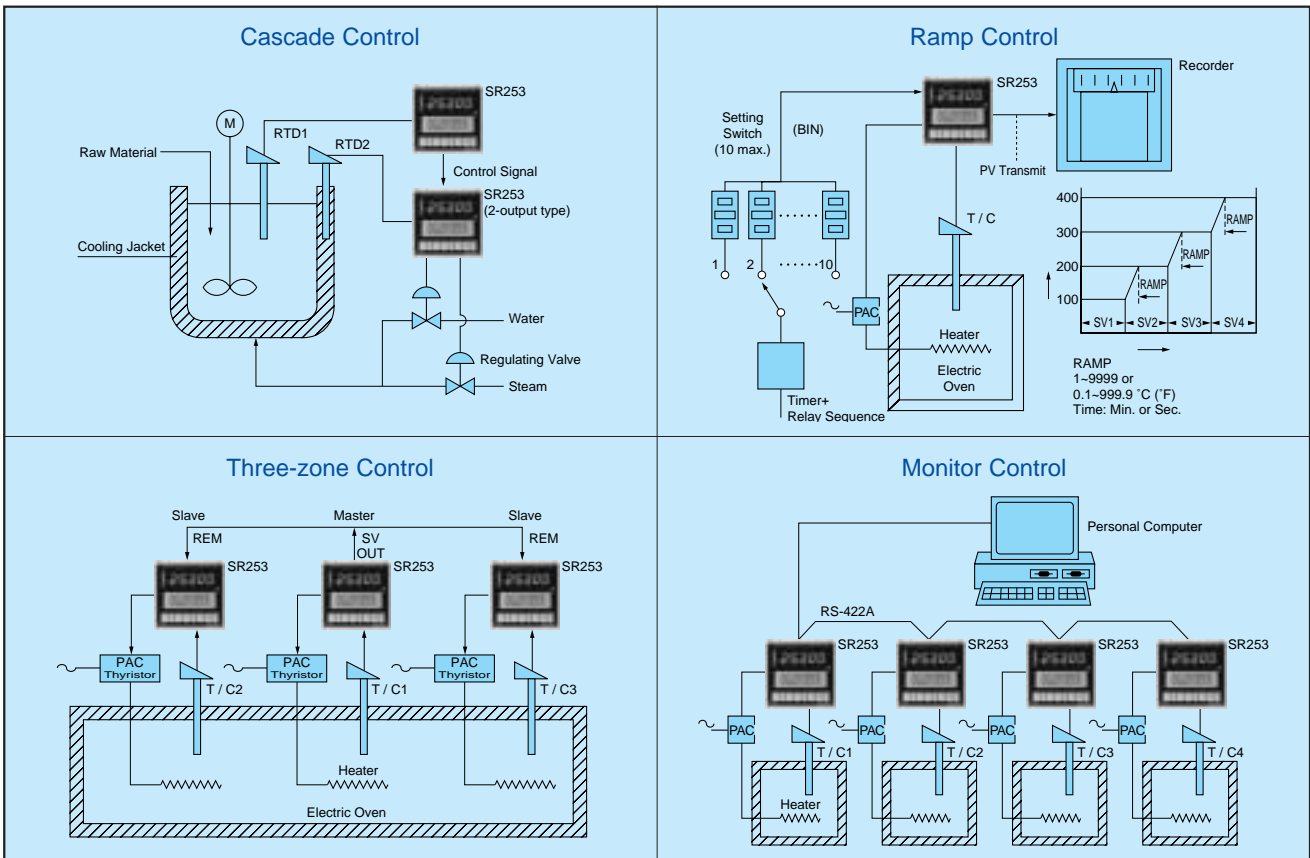

ITEMS	CODE		SPECIFICATIONS
SERIES	SR253-		MPU-Based PID Auto-Tuning Controller, DIN 96 × 96 mm
INPUT	1		Thermocouple, User-selectable inputs and ranges
	2		R.T.D. (Pt100), User-selectable ranges
	3		DC Voltage, User-selectable 0~10, 10~50, 0~20, 0~50, 0~100, -10~10, -100~100mV linear inputs and ranges
	4		DC Current, User-selectable 4~20, 0~20mA linear inputs and ranges
	6		DC Voltage, User-selectable 0~1, 1~5, -1~1, 0~2, 0~5, 0~10, -10~10V linear inputs and ranges
CONTROL OUTPUT 1	Y-		Contact: PB Cycle 1~200 seconds variable, Capacity: 240V AC 2.5A / Resistive load, 1A / Inductive load
	I-		Current: 4~20mA DC, Load resistance: 600Ω max. (Factory set=RA)
	P-		SSR Voltage: PB Cycle 1~200 seconds variable, Output rating: 12±1.5V DC / 30mA max.
	V-		Voltage: 0~10V DC, Maximum load current: 2mA max. (Factory set=RA)
CONTROL OUTPUT 2 (HEAT/COOL CONTROL) (OPTION)	N-		None (Select one output model)
	Y-		Contact: PB Cycle 1~200 seconds variable, Capacity: 240V AC 2.5A / Resistive load, 1A / Inductive load
	I-		Current: 4~20mA DC, Load resistance: 600Ω max. (DA)
	P-		SSR Voltage: PB Cycle 1~200 seconds variable, Output rating: 12±1.5V DC / 30mA max.
EVENT OUTPUT/HEATER BREAK ALARM (OPTION) *FOR H. B. ALARM, SELECTABLE ONLY WHEN CONTROL OUTPUT 1 IS Y OR P	0		None
	1		Event contact output - 3 points
	2		Event contact output - 3 points + heater break alarm (heater current 30A)
	3		Event contact output - 3 points + heater break alarm (heater current 50A)
REMOTE INPUT (OPTION)	06		0~10V DC, Input resistance: 500kΩ min.
	04		4~20mA DC, Receiving resistance: 250Ω
	05		1~5V DC, Input resistance: 500kΩ min.
	14		4~20mA DC, Receiving resistance: 250Ω
	15		1~5V DC, Input resistance: 500kΩ min.
	16		0~10V DC, Input resistance: 500kΩ min.
ANALOG OUTPUT (TRANSMISSION) (OPTION)	00		None
	13		1-Output, Voltage: 0~10mV DC / Output resistance: 10Ω
	14		1-Output, Current: 4~20mA DC / Load resistance: 300Ω max.
	16		1-Output, Voltage: 0~10V DC / Max. load current: 1mA max.
	23		2-Output, Voltage: 0~10mV DC / Output resistance: 10Ω
	24		2-Output, Current: 4~20mA DC / Load resistance: 300Ω max.
	26		2-Output, Voltage: 0~10V DC / Max. load current: 1mA max.
EXTERNAL INPUT AND OUTPUT CONTROL SIGNAL (OPTION)	0		Without
	1		With: 24-pin plug and socket only. Select (SV <sub>1</sub> ~SV <sub>10</sub> ), input (DI1~DI4) and output Open collector (DO1~DO5).
	2		With: 24-pin plug w/1-meter wire. Select (SV <sub>1</sub> ~SV <sub>10</sub> ), input (DI1~DI4) and output Open collector (DO1~DO5).
INTERFACE FUNCTION (OPTION)	0		Without
	5		RS-485
	6		RS-422A
	7		RS-232C
REMARKS	0		Without
	9		With (Please consult before ordering.)

**Notes:**

1. All the event output signals of the SR253 Series are now optional functions.

2. For example :

a. If the open collector output signal (DO1-DO5) of the events is required, Select (0) of Item 5 and then (1) or (2) of Item 8 in the Ordering Information table.

When (0) of Item 5 and (0) of Item 8 of the Ordering Information table are selected, the connector (24-pin plug) for open collector output signal is not attached and therefore, no open collector output signal is produced.

b. If the even contact output signal (EV1-EV3) is required, select (1) of Item 5 and then (0) of Item 8 in the Ordering Information table.

c. If both an event contact output signal (EV1-EV3) and the open collector output Signal are required, select (1) of Item 5 and then (1) or (2) of Item 8 in the Ordering Information table.

Since the Series SR253- has been designed for user-selectable inputs, user-selectable ranges and user-programmable scaling, the unit will be shipped with one factory-set standard range.

If a range selection other than the standard is required, user-selectable inputs (T/C's) and user-selectable ranges (T/C's & RTD) are available as listed below.

### Standard Range (Factory-Set when shipping)

Input	Standard / Rating	Ranges
1 Thermocouple	(K)	0.0~800.0°C
2 R.T.D.	Pt100	0.0~200.0°C
3 DC Voltage	0~10mV	0.0~100.0%
4 DC Current	4~20mA	0.0~100.0%
6 DC Voltage	0~10V	0.0~100.0%

### User-Programmable Scaling (Current or Voltage)

Range No.	Voltage (mV)	Current (mA)	Voltage (V) *1
1	-10~ 10	-	-1~ 1
2	0~ 10	-	0~ 1
3	0~ 20	-	0~ 2
4	0~ 50	0~20	0~ 5
5	10~ 50	4~20	1~ 5
6	0~100	-	0~10
7	-100~100	-	-10~10

### User-Selectable Range (Thermocouple)

Range No.	Type of Input	Measuring Range		
		°C	°F	K
1	B	0.0 ~ 1800.0	0 ~ 3300	-
2	R	0.0 ~ 1700.0	0 ~ 3100	-
3	S	0.0 ~ 1700.0	0 ~ 3100	-
4	K	-100.0 ~ 400.0	-150.0 ~ 750.0	-
5	K	0.0 ~ 400.0	0.0 ~ 750.0	-
6	K	0.0 ~ 800.0	0.0 ~ 1500.0	-
7	K	0.0 ~ 1200.0	0.0 ~ 2200.0	-
8	K	-200.0 ~ 200.0	-300.0 ~ 400.0	-
9	E	0.0 ~ 700.0	0.0 ~ 1300.0	-
10	J	0.0 ~ 600.0	0.0 ~ 1100.0	-
11	T	-200.0 ~ 200.0	-300.0 ~ 400.0	-
12	N	0.0 ~ 1300.0	0.0 ~ 2300.0	-
13	PL II	0.0 ~ 1300.0	0.0 ~ 2300.0	-
14	PR40-20	0.0 ~ 1800.0	0 ~ 3300	-
15	WRe5-26	0.0 ~ 2300.0	0 ~ 4200	-
16	U	-200.0 ~ 200.0	-300.0 ~ 400.0	-
17	L	0.0 ~ 600.0	0.0 ~ 1100.0	-
18	K	-	-	10.0 ~ 350.0
19	Gold iron / chromel	-	-	0 ~ 350.0

Initial value: Range No.6 (K thermocouple 0.0~800.0°C)

Note 1: In the case of B thermocouple, accuracy is not guaranteed at temperatures below 400°C (750°F).

Note 2: The precision for PR40-20 is ±(0.3% FS+1°C)

Note 3: The precision for K thermocouple (Kelvin) is:  
 10.0~ 30.0 K : ±(0.75% FS+1K)  
 30.0~ 70.0 K : ±(0.30% FS+1K)  
 70.0~350.0 K : ±(0.25% FS+1K)

Note 4: The precision for the gold iron / chromel thermocouple is ±(0.25% FS+1K)

### User-Selectable Range (R.T.D.)

Range No.	Type of Input	Measuring Range	
		°C	°F
1	Pt100 (JPt100)	-200.0 ~ 600.0	-300.0 ~ 1100.0
		-200.0 ~ 500.0	-300.0 ~ 900.0
2	Common to Pt100 and JPt100	-100.00 ~ 100.00	-150.0 ~ 200.0
3		-100.0 ~ 100.0	-150.0 ~ 200.0
4		-100.0 ~ 300.0	-150.0 ~ 600.0
5		-60.00 ~ 40.00	-80.0 ~ 100.00
6		-50.00 ~ 50.00	-60.00 ~ 120.00
7		-40.00 ~ 60.00	-40.0 ~ 140.00
8		-20.00 ~ 80.00	0.00 ~ 180.00
9		0.000 ~ 50.000	0.00 ~ 120.00
10		0.00 ~ 50.00	0.00 ~ 120.00
11		0.00 ~ 100.00	0.00 ~ 200.00
12		0.0 ~ 100.0	0.0 ~ 200.0
13		0.00 ~ 200.00	0.0 ~ 400.0
14		0.0 ~ 200.0	0.0 ~ 400.0
15		0.0 ~ 300.0	0.0 ~ 600.0
16		Pt100 (JPt100)	0.0 ~ 500.0
	0.0 ~ 500.0		0.0 ~ 900.0

Initial value: Range No.14 (Pt100 0.0~200.0°C)

Note 5: The precision of 50°C (120°F) span input is ±0.2% FS.

\*1 Initial value: Voltage (mV) input; Range No.2 (0-10mV)  
 Current (mA) input; Range No.5 (4-20mA)  
 Voltage (V) input; Range No.6 (0-10V)



Relay Unit  
Model AP2MC  
for converting  
contact output  
into open  
collector output



SV No.  
Selector Model  
KA251 for  
selecting  
SV1~SV10 BIN  
cord



24-pin Plug  
Cord Model  
CA2530-01  
with crimp  
terminal  
shielding wire  
and mark band  
(1m)

**ACCESSORIES REQUIRED FOR HEATER BREAK ALARM FUNCTION (COMMON)**

• CT wiring

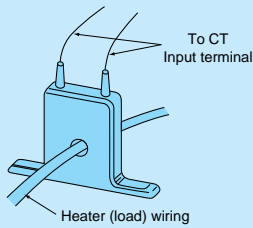

• 30A (CTL-6-S)

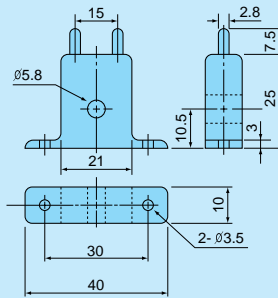

• 50A (CTL-12-S36-8)

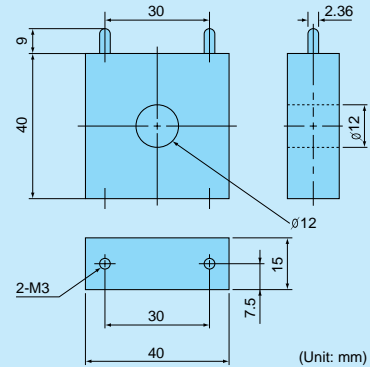

(Unit: mm)

**EXTERNAL DIMENSIONS & PANEL CUTOUT**

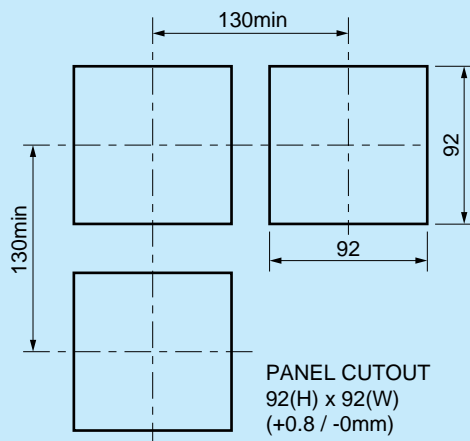
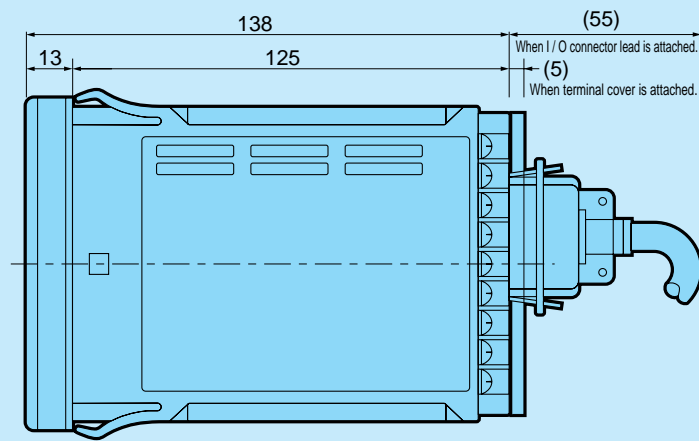
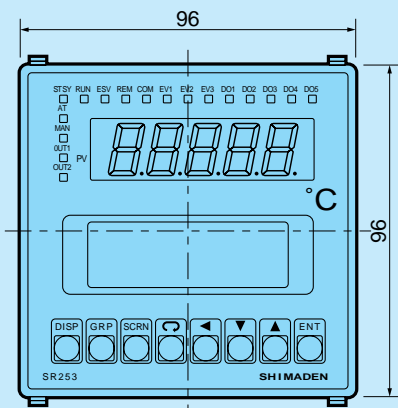

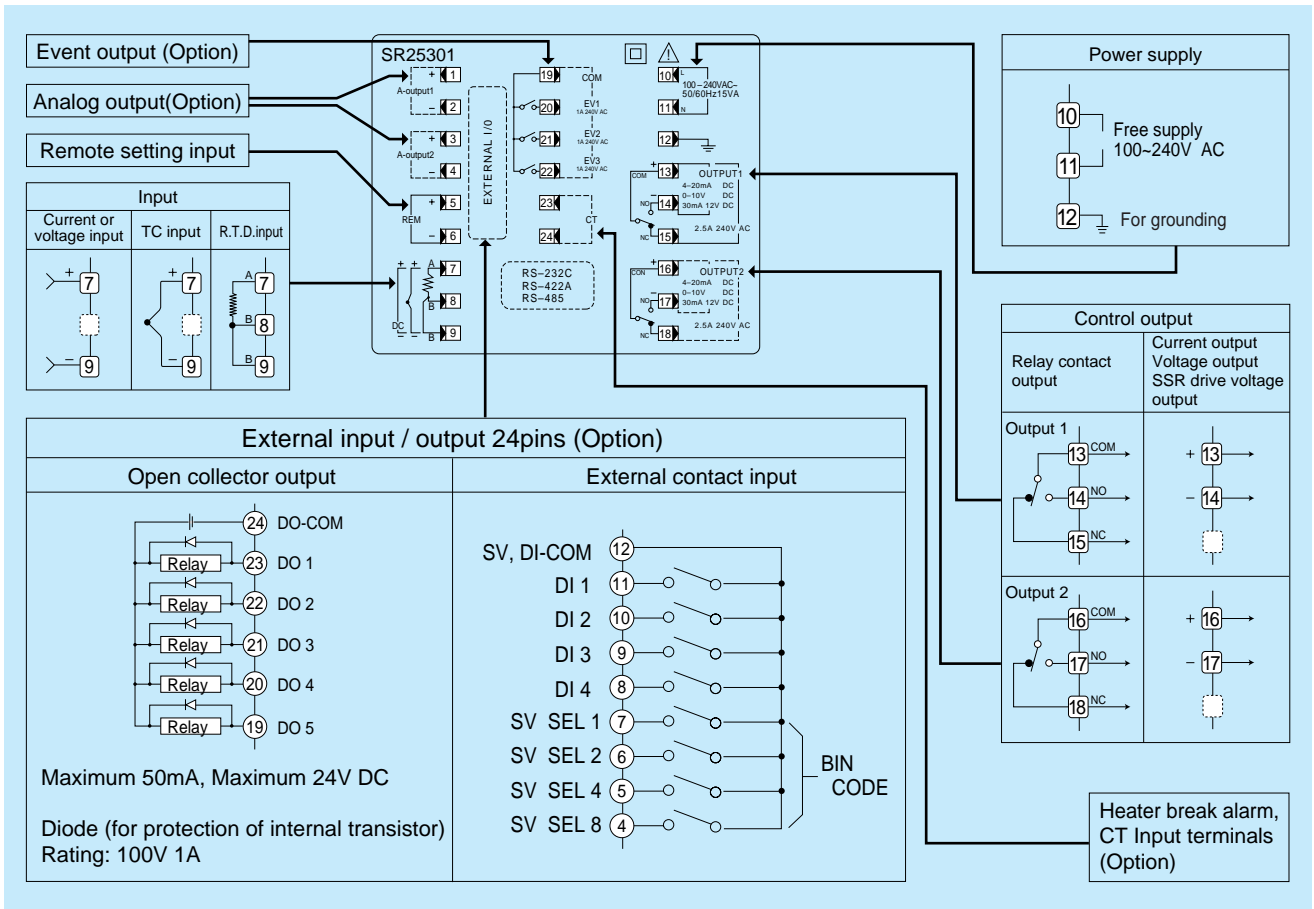

**Warning**

- The SR253 series is designed for the control of temperature, humidity and other physical values of general industrial equipment. (It is not to be used for any purpose which regulates the prevention of serious effects on human life or safety.)

**Caution**

- If the possibility of loss or damage to your system or property as a result of failure of any part of the process exists, proper safety measures must be made before the instrument is put into use so as to prevent the occurrence of trouble.



ISO 9001

(The contents of this brochure are subject to change without notice.)

Temperature and Humidity Control Specialists

**SHIMADEN CO., LTD.**

Head Office: 2-30-10 Kitamachi, Nerima-Ku, Tokyo 179-0081 Japan  
 Phone: +81-3-3931-7891 Fax: +81-3-3931-3089  
 E-MAIL: exp-dept@shimaden.co.jp URL: http://www.shimaden.co.jp

Distributed in New Zealand by:

**Intech** INSTRUMENTS LTD

Christchurch Auckland [www.intech.co.nz](http://www.intech.co.nz)  
 Ph: +6433430646 098271930 sales@intech.co.nz  
 Fx: +6433430649 098271931