

New Release Products from Intech Instruments!

3

Transmitters: Loop powered and 4 wire powered



NEW Universal Input Transmitters - XU Series: Temperature, mA, mV & V, Potentiometer.

4

Dual Transmitter & 4 Wire Universal Input Transmitter: Temperature, mA, mV & V, Bridge/Straingauge, Potentiometer.

5

Loop Powered Transmitters (2 wire): Temperature, DC, Bridge, Potentiometer, AC current.

6

Plug-in Transmitters: DC, Frequency, Bridge, Resistance, Potentiometer, Set point alarm, Maths.

7

XI 4~20mA DC Isolator Series: XI-L 4~20mA Loop Powered Isolators and XI-P 4~20mA Input Powered Isolators.

8

Loop Powered Frequency Transmitter (2 Wire): Flow meters and other devices with low level output.

10

Transmitters: Frequency, Pressure, pH, Humidity, Light



Frequency Transmitters: 4~20mA to Frequency for direct conversion into a PLC digital input. Frequency to frequency divider.

11

NEW IN-HWD Humidity Indicator Transmitter, **WDT-DW** Humidity wet & dry tank.

12

LPN-H Humidity & Temperature Transmitters: Two 2 wire Loop Powered Transmitters.

12

Pressure Transmitters: 6 ranges from mm WG to KPa/psi.

13

LPI-pH pH Transmitter.

13

TWN-LUX Light intensity Transmitter.

15

Generators, Filters, Calibrators, Power Supplies



Line Filter / Flow Amplifier / Optical Isolator.

9

PSW Instrument Power Supplies: DC Output Switch Mode Power Supplies.

14

PSW-2-F Instrument Power Supply: Fixed 24Vdc, 200mA output, **IN-GEN** Signal Generator, **LPN-OVP** Over Voltage protection.

15

NEW Process Indicators - IN Series



IN-P Multifunctional Indicator.

16

IN-R Large Display Tachometer, **IN-RT** Flow Rate with Totaliser, **IN-RTB** Flow Rate and Batching Controller.

17

LPI-LCD-5 Panel Mount Indicator: Loop powered.

17

Intech Micro Multiplexers and I/O Remote Stations



2100-M Analogue Input Multiplexers: RTD and Milli-amps Inputs.

18

2100-A16 configured as an Intelligent Multiplexer: Pt100/Pt1000, Tc, mA, mV & V. Each input channel individually configurable.

19

2100-AO configured as a PLC Analogue Output Multiplexer.

20

2300 Series - Analogue and Digital I/O Remote Stations



22

2100-D Digital Input & Relay Output Remote Station.

24

2100-R2 Relay Output Expansion: Relay output expansion for the 2100-A16 or 2100-A4.

24

2100-AO Analogue and Digital I/O Remote Station.

25

2100-A16 Remote Station: Pt100 or Pt1000, Thermocouple, mA, mV & V. Each input channel individually configurable plus digital I/O & AO.

26

2100-A4 Remote Station: Pt100, Thermocouple, Thermistor, mA, mV & V. Each input channel individually configurable plus digital I/O & AO.

27

Serial and Ethernet Converters



2100-IS: Isolated and 2100-NS: Non Isolated RS232 to 422/485 converters.	21
USB485: USB to RS485 Non Isolated converter.	21
2100-NET: Ethernet to RS232, 422 & 485 converter.	21

Mini Packs PC Recorder Kits – includes MicroScan Recorder Lite plus Intech Micro I/O Remote Station(s)

Mini Pack 8: 8 channel Recorder - Voltage/Current/Thermocouple/RTD/Multi.	28
Mini Pack 16: 16 channel Recorder - Pt100 or Pt1000, Tc, mA, mV & V, digital inputs plus alarm outputs and analogue retransmission.	28
Mini Pack 32: 32 channel Recorder - Pt100 or Pt1000, Tc, mA, mV & V, digital inputs plus alarm outputs and analogue retransmissions.	28

Schematic showing connection of 2100 series plus controllers to PC and PLC

MicroScan Recorder and SCADA Software



MicroScan Recorder features.	30
MicroScan Mimic features: Mimics plus support for controllers, PLC's, Network, and MicroScan Tool Box special function generator.	31
MicroScan listed with all options: Version 5.	32
MA5 MicroScan Mobile Alarming 5 software: Alarms & queries transmitted to: mobile phone text messages, email, factory PA.	33
Shimaden Lite: Free software for Shimaden controllers and indicators with comms.	33
<u>NEW</u> Wireless MicroScan Communications: New ZigBee® Technology for MicroScan wireless data links, Z-2400 Series.	34
2.4GHz High Gain Antennas: Increase wireless systems distances, Tel-Link Radio Modems: High speed wireless data links.	35

Mini Data Loggers and Logger Software



HR series: RTD Pt100/Pt500/Pt1000, Thermocouple, Humidity, pH, Water level, mA, mV & V, single and multi channel.	36
Data loggers & OmniLog: Data management software for TruTrack data loggers.	37
GP-MC: Multi purpose data logger.	38
LCD Data Loggers: Handheld data loggers with liquid crystal display: Humidity, Thermocouple, RTD Pt100/Pt500/Pt1000 and Pressure.	39
Environmental Monitoring Systems: Small & Medium.	40
Weather Sensor Transmitters: 4~20mA output signals.	41

pH Probes plus pH transmitter



Intech Instruments Ltd - Conditions of Sale.	44
---	----

LATEST PRODUCT RELEASES FROM INTECH INSTRUMENTS!

NEW!

XU SERIES - UNIVERSAL INPUT TRANSMITTERS

- ⇒ Programmable with simple software via USB connection.
- ⇒ No power required during programming.
- ⇒ No calibration required for range changes.
- ⇒ Fully isolating 3750Vac (excluding XU2HN).
- ⇒ Zero Adjust pot (excluding XU2HN).
- ⇒ High accuracy 0.1%.

For more information please see page 4. >>



PSW-2-F - INSTRUMENT POWER SUPPLY 24Vdc

NEW!

- ⇒ Fixed Power Supply 24Vdc.
- ⇒ Output Current of 200mA.
- ⇒ Powers up to 10x 4~20mA 2-wire loops.
- ⇒ Low noise and High precision.
- ⇒ Input Power Supply: 85~265Vac/dc.

For more information please refer to page 15. >>



IN SERIES - PROCESS INDICATORS

NEW!

Each model features:

- ⇒ Simple setup and calibration.
- ⇒ On screen step by step instructions.
- ⇒ 5 buttons for easy operator interface.
- ⇒ Option to add up to 6 relay outputs.
- ⇒ Analogue output retransmission option.
- ⇒ Serial RS485/RS232 port option with Modbus RTU (excluding IN-R).
- ⇒ Wide range of Power Supply options.

For more information please refer to pages 16 and 17. >>

NEW!

WIRELESS MICROSCAN CONNECTIONS ZIGBEE TECHNOLOGY - Z-2400 SERIES

- ⇒ Wireless standard: IEEE 802.15.4-2006.
- ⇒ Wireless range: 100m typical line of sight.
- ⇒ Power supply: 12~24Vdc.
- ⇒ Power Consumption: 5 VA.

For more information please see page 34. >>







XU2 (2 Wire) Universal Input

- Programmable via USB (requires XU-USB key).
- No power supply or calibration required during programming.
- 2 wire 4~20mA output. Loop powered.
- 3750Vac isolation.
- High accuracy 0.1%.
- Reverse Polarity Protected.
- Zero Adjust pot.
- Heartbeat Status LED.
- Compact DIN Rail Mount Enclosure.
- Available Standard or Special Calibration.

	MODEL	DESCRIPTION	For Ordering Code & Specification Refer Web:
	XU2	Single Universal Input Transmitter. Input types: mV, V, & mA. RTD Pt100 / Pt1000. Thermocouple (T/C). Potentiometer. Output: 2 wire 4~20mA.	www.intech.co.nz/xu2
	XU-USB	USB Programming Key	

XU2HI & XU2HN (2 Wire) Head Mount

- Single Temperature (RTD/Thermocouple) Input In-Head Transmitter.
- Programmable via USB (requires XU-USB key).
- No power supply or calibration required during programming.
- 2 wire 4~20mA output. Loop powered.
- High accuracy 0.1%.
- Reverse Polarity Protected.

	MODEL	DESCRIPTION	For Ordering Code & Specification Refer Web:
	XU2HI	Single Temperature Input Transmitter. For mounting in a probe head. Isolating. Isolation: 3750Vac. Heartbeat Status LED. Zero Adjust pot. Input types: RTD Pt100 / Pt1000. Thermocouple (T/C). Output: 2 wire 4~20mA.	www.intech.co.nz/xu2h
	XU2HN	Single Temperature Input Transmitter. For mounting in a probe head. Non-isolating. Input types: RTD Pt100 / Pt1000. Thermocouple (T/C).* Output: 2 wire 4~20mA.	
	XU-USB	USB Programming Key	www.intech.co.nz/xu2h

*Note: Thermocouple I/P is not recommended on Non-Isolated Transmitters unless care is taken with system design.

XU4 (4 Wire) Universal Input

- Programmable via USB (requires XU-USB key).
- No power supply or calibration required during programming.
- 3750Vac isolation.
- High accuracy 0.1%.
- Reverse Polarity Protected.
- Heartbeat Status LED.
- Zero Adjust pot.
- Compact DIN Rail Mount Enclosure.
- Available Standard or Special Calibration.
- Universal ac/dc Power Supply: 20~265Vac and 21~265Vdc.

	MODEL	DESCRIPTION	For Ordering Code & Specification Refer Web:
	XU4	Single Universal Input Transmitter. Input types: mV, V, & mA. RTD Pt100 / Pt1000. Thermocouple (T/C). Potentiometer. Output types: Current - e.g. 4~20mA. Voltage - e.g. 0~10V.	www.intech.co.nz/xu4
	XU-USB	USB Programming Key	

Note: The same XU-USB Programming Key can be used to program any of the XU Series Transmitters - just change the included adaptor plug for DIN or In-head!



XJ UNIVERSAL INPUT TRANSMITTERS

XJ22 (2 Wire) Universal Input Loop Powered, Dual Transmitter

- Field Programmable Bi-Polar Input Ranges.
- 2 wire 4~20mA dual outputs. Loop powered.
- 2.0 kV isolation.
- 0.1% accuracy.
- Reverse Polarity Protected.
- LED indication of loop current.
- Compact DIN Rail Mount Enclosure.
- Available Standard or Special Calibration.

	MODEL	DESCRIPTION	For Ordering Code & Specification Refer Web Page:
	XJ22	Dual Transmitter. Input types: mV, V, & mA. RTD Pt100. Differential RTD. Thermocouple (T/C). Bridge/Strainguage. Potentiometer. Resistance. Outputs: 2 wire 4~20mA.	www.intech.co.nz/xj22

Also see our **XU Series** USB Programmable Universal Input Transmitters on page 4. <<

XJ4 (4 Wire) Universal Input Universal Power Supply

- Field Programmable Bi-Polar Input and Output Ranges.
- 2.0 kV isolation.
- 0.1% accuracy.
- Transmitter Power Supply.
- Compact DIN Rail Mount Enclosure.
- Available Standard or Special Calibration.
- Universal ac/dc Power Supply:
85~264Vac/dc or 22~90Vdc Selectable,
10~28Vac/dc Optional.

	MODEL	DESCRIPTION	For Ordering Code & Specification Refer Web Page:
	XJ4	Input types: mV, V, & mA. RTD Pt100. Differential RTD. Thermocouple (T/C). Bridge/Strainguage. Potentiometer. Resistance. Field Programmable Output types: Current: Voltage: 4~20mA 0~5V 0~20mA 0~10V -10~10mA 2~10V -20~20mA -5~5V -10~10V	www.intech.co.nz/xj4
		Other output current and voltage ranges available.	

LOOP POWERED TRANSMITTERS

- Output, 4~20mA loop powered.
- 2 kV isolation for LPI series.
- 0.1% accuracy.
- 40~200mV output test signal.
- LED indication of loop current.



LPN-R-H



MODEL	DESCRIPTION	For Ordering Code & Specification Refer Web Page:	
LPI-D-F	DC to DC isolating signal transmitter. Fixed input range: 4~20mA.	www.intech.co.nz/lpi-d	DC signal
LPI-D-P	DC to DC isolating signal transmitter. Programmable input ranges: from 0~10mV to 150V and: from 0~200uA to 50mA.	www.intech.co.nz/lpi-d	
LPI-B	Bridge to DC isolating signal transmitter. Programmable input ranges from 0~1mV to 800mV.	www.intech.co.nz/lpi-b	Bridge
LPI-P	Potentiometer to DC isolating transmitter. Programmable input span from 0~10% to 0~100%. Elevated zero or suppressed span. Resistance range from 0~1000 ohm to 0~1 Meg ohm.	www.intech.co.nz/lpi-p	Potentiometer
LPN-P	Potentiometer to DC non-isolating transmitter. Programmable input span from 0~20% to 0~100%. Resistance range from 0~1000 ohm to 0~1 Meg ohm.	www.intech.co.nz/lpn-p	
LPI-R-F	RTD to DC isolating transmitter. Pt100, others by request. Fixed ranges from -200~0~20 to 500°C/F.	www.intech.co.nz/lpi-r	RTD
LPI-R-P	RTD to DC isolating transmitter. Pt100, others by request. Programmable ranges from -200~0~20 to 500°C/F.	www.intech.co.nz/lpi-r	
LPN-R-X1 LPN-R-X2	RTD to DC non-isolating transmitter. Programmable ranges from -100~0~30 to 600°C/F. Standard input Pt100, others by request. Single RTD to DC non-isolating transmitter. Dual RTD to DC non-isolating transmitters.	www.intech.co.nz/lpn-r	
LPN-R-H	RTD to DC non-isolating transmitter. For mounting in a probe head. Programmable ranges from -100~0~30 to 600°C/F. Pt100 input. Double mounting screw holes are at 40mm or 33mm centres. Option for DIN Rail Mount Foot.	www.intech.co.nz/lpn-r-h	<i>Note:</i> For our isolating programmable (including input type) In-Head transmitter please see the XU2HI on page 4.
LPI-T-F	Thermocouple to DC isolating transmitter. Fixed ranges from -100~0~200 to 1700°C/F. Available for type K, J, N, R, S, T.	www.intech.co.nz/lpi-t	Thermocouple
LPI-T-P	Thermocouple to DC isolating transmitter. Programmable ranges from -100~0~200 to 1700°C/F. Available for type K, J, N, R, S, T.	www.intech.co.nz/lpi-t	
LPI-CT-X1 LPI-CT-X2	AC current to DC isolating transmitter. Selectable input, 0~1 Amp ac or 0~5 Amp ac. Special ranges on request. Single LPI-CT transmitter. Dual LPI-CT transmitters.	www.intech.co.nz/lpi-ct	AC current

PLUG-IN TRANSMITTERS





- Input and output ranges are field programmable.
- Bi-polar - Input and output signals.
- 1.6kV isolation.
- 0.1% accuracy.
- Plug-in-DIN rail mount base.
- Special calibration available.
- Power supply: 85~264Vac/dc or 22~85Vac/dc selectable.

MODEL	DESCRIPTION	For Ordering Code & Specification Refer Web Page:	
PI-D	DC to DC isolating signal transmitter. Programmable input ranges from 0~10mV to 150V, 0~200uA to 50mA. Programmable output ranges from 0~500mV to 12V, 0~1mA to 20mA. On board 20Vdc power supply for primary transmitter.	www.intech.co.nz/pi-d	DC signal
PI-F	Frequency to DC isolating signal transmitter. Programmable input ranges from 0~0.4 Hz to 40 kHz. Programmable output ranges from 0~500mV to 12V, 0~1mA to 20mA. On board 12Vdc 50mA power supply for primary signal.	www.intech.co.nz/pi-f	Frequency
PI-B	Bridge to DC isolating signal transmitter. Programmable input ranges from 0~1mV to 1000mV. Programmable output ranges from 0~500mV to 12V, 0~1mA to 20mA. On board precision 10Vdc 30mA power supply for bridge excitation.	www.intech.co.nz/pi-b	Bridge/ Strain gauge
PI-M	Maths function, DC to DC isolating transmitter with 3 inputs. Programmable V and mA input ranges. Programmable output ranges from 0~500mV to 12V, 0~1mA to 20mA. 32 predetermined programmable math functions. 120 point user defined curve fitting.	www.intech.co.nz/pi-m	Maths function
PI-RAC	RS232 adapter cable for connecting the PI-M to a computer. Uses Windows Notepad or Excel in conjunction with Windows Hyper Terminal.	www.intech.co.nz/pi-rac	
PI-K	Resistance to DC isolating transmitter. Programmable input ranges from 0~10 ohms to 20k ohms. Programmable output ranges from 0~500mV to 12V, 0~1mA to 20mA.	www.intech.co.nz/pi-k	Resistance
PI-P	Potentiometer to DC isolating transmitter. Resistance range from 0~200 ohms to 0~1M ohms. Programmable input span from 0~10% to 0~100%. Elevated zero or suppressed span available. Programmable output ranges from 0~500mV to 12V, 0~1mA to 20mA.	www.intech.co.nz/pi-p	Potentiometer
PI-S	Set point alarm unit. Two set points, two relay outputs. Programmable input ranges from 0~5V to 10V, 0~10mA to 50mA. The action of the two alarm relays is selectable, high, low, window & differential. Selectable N/O-N/C contacts. Adjustable time delay of 0.2~30 sec.	www.intech.co.nz/pi-s	Set point alarm

XI 4~20mA ISOLATOR SERIES

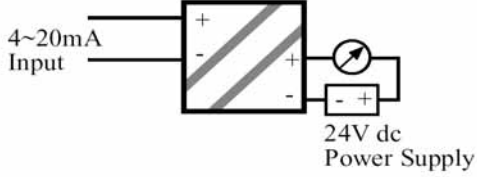

XI-L Loop Powered Isolators

- Isolating 4~20mA Input to 4~20mA Output Transmitter.
- Input to Output Isolation 1kV.
- High Accuracy 0.1%.
- Loop Powered.
- Reverse Polarity Protected.
- Compact DIN Rail Mount Enclosure.
- Available with 1, 2 or 4 transmitters per Enclosure.
- Easy to Install.

XI-L1	XI-L2	XI-L4	For Ordering Code & Specification Refer Web Page:
One Isolator	Dual Isolators	Quad Isolators	www.intech.co.nz/xi-l
			<p>Typical Hookup</p> <p>XI-L</p> 

XI-P Input Powered Isolators

- 4~20mA Input Powered to 4~20mA Output Isolation Transmitter.
- Ideal for isolating a typical 4~20mA loop.
- Also good for Line Filtering at the Receive end of Line.
- No Power Supply Needed - Input Powers Output.
- Input to Output Isolation 1kV.
- High Accuracy.
- Reverse Polarity Protected.
- Compact DIN Rail Mount Enclosure.
- Available with 1, 2 or 4 transmitters per Enclosure.
- Easy to Install.

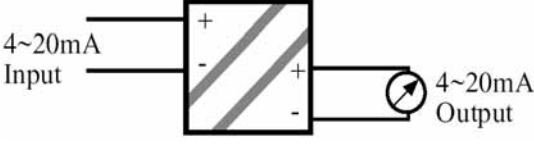
XI-P1	XI-P2	XI-P4	For Ordering Code & Specification Refer Web Page:
One Isolator	Dual Isolators	Quad Isolators	www.intech.co.nz/xi-p
			<p>Typical Hookup</p> <p>XI-P</p> 

IN-LF - Line Filter

The IN-LF is designed as an economical and reliable protection against high-voltage transients and surges, and other electrical noise, produced for example by lightning, switching and electrical noise on AC or DC power lines.

MODEL	DESCRIPTION	For Ordering Code & Specification Refer Web Page:
IN-LF 	Line filter. Voltage: 210~250Vac (others by request). Output: Max. load = 3 Amps.	www.intech.co.nz/in-lf

TW-FFA - Flow Amplifier

The TW-FFA Flow Amplifier was designed and manufactured specifically for use with flow transducers (or other ac/dc waveforms) to provide a stable and amplified output for further processing. The input voltage signal from a flow transducer is amplified to a square wave output. Typical applications include flow totalisation and rate of fluids in pipe sizes ranging from ½" to 96" diameter.

MODEL	DESCRIPTION	For Ordering Code & Specification Refer Web Page:
TW-FFA 	Flow pulse amplifier. (was IN-FFA). Power supply: 5~32Vdc. Input: Flow meter impeller or mV; ac or dc frequency. Output: Square wave, 200mA / 24Vdc. 10kHz max.	www.intech.co.nz/tw-ffa

IN-OID - Optical Isolator

The IN-OID is an Interface for the purpose of potential free matching and protection of on/off dc input process signals to on/off dc output signals.

MODEL	DESCRIPTION	For Ordering Code & Specification Refer Web Page:
IN-OID 	Optical isolator for digital signals. Input: 5Vdc, 12Vdc, 15Vdc, 24Vdc, 110Vdc, 4Vac. Output: Open collector 30Vdc, 100mA maximum. Isolation: 3kV.	www.intech.co.nz/in-oid

FREQUENCY TO DC LOOP POWERED TRANSMITTER

- Output, 4~20mA loop powered.
- 2kV isolation.
- 0.1% accuracy.
- 40~200mV output test signal.
- LED indication of loop current.

	MODEL	DESCRIPTION	For Ordering Code & Specification Refer Web Page:
	LPI-F-D	Frequency to DC isolating signal transmitter.	Hz to 4~20mA www.intech.co.nz/lpi-f
	DIN rail mount unit	Programmable ranges from 0~15Hz to 0~10kHz. <i>Input:</i> 2 wire. Sine, Square, Pulse. Uni-polar or Bi-polar. (Signals <2Vpp Bipolar only). Minimum input signal: 10mVpp @ 100Hz. 100mVpp @ 1kHz. 1Vpp @ 10kHz. Maximum input signal: 100V pp. (100Hz max for contact closure). <i>Output:</i> 2 wire, 4~20mA loop powered. 800 ohms at 24Vdc.	

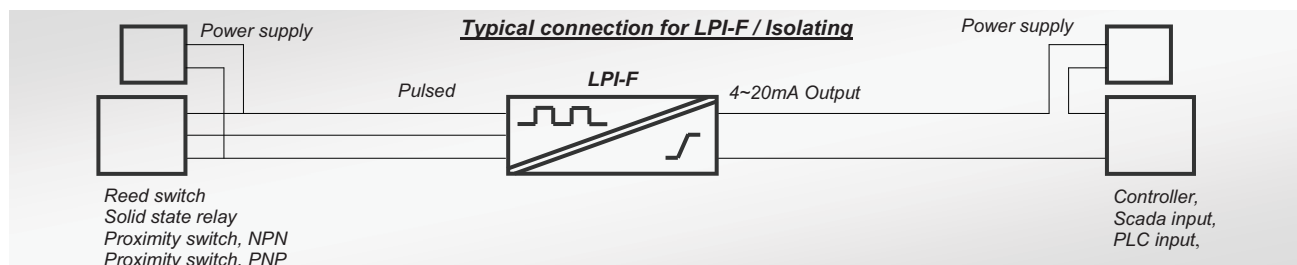
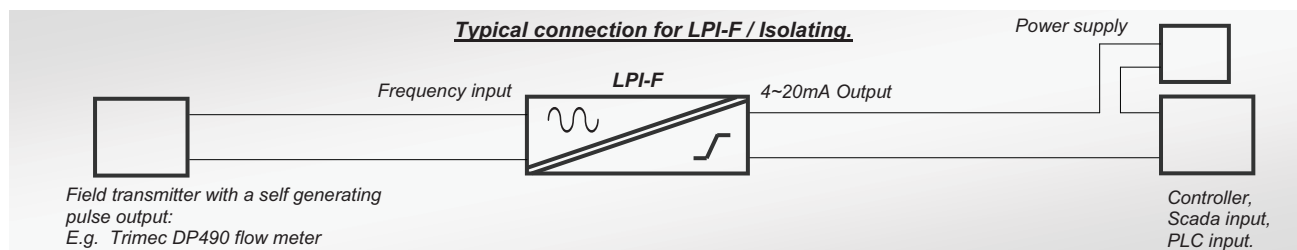

DC TO FREQUENCY TRANSMITTERS

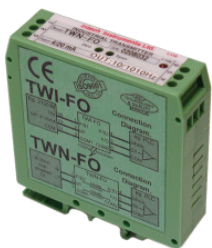
	MODEL	DESCRIPTION	For Ordering Code & Specification Refer Web Page:
	TWI-FO	Isolating DC to frequency interface. Converts a 4~20mA signal to a frequency for direct conversion into a PLC digital input. LED indication of Hz output. 1.6kV isolation. Power supply: 11~28Vdc. Standard input: 4~20mA, others by request. Standard output: 10~1010Hz, others by request.	4~20mA to Hz Converter www.intech.co.nz/tw-fo
	TWN-FO	Non-isolating DC to frequency interface. As above.	

Typical connection for TWN-FO / Non-Isolating

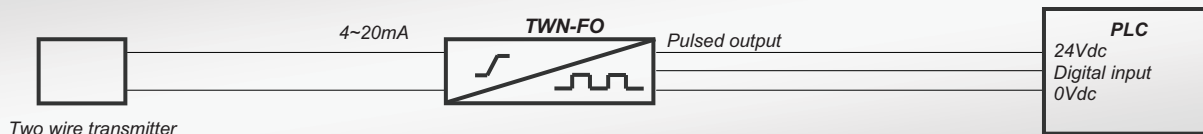

Typical connection for TWI-FO / Isolating

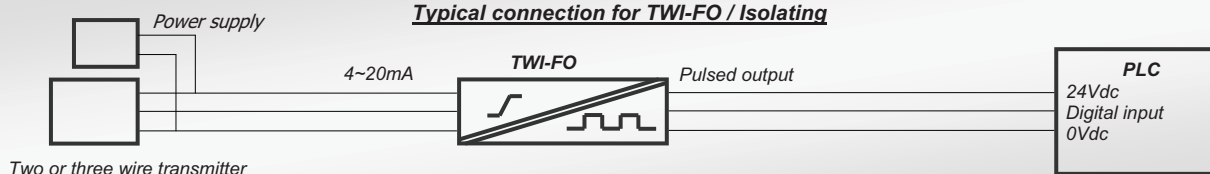

FREQUENCY TO FREQUENCY TRANSMITTERS

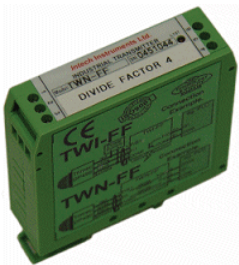
	MODEL	DESCRIPTION	For Ordering Code & Specification Refer Web Page:
	TWI-FF	Isolating frequency input, divided, to open collector frequency output interface. LED indication of Hz output. 1.6kV isolation. Power supply: 11~28Vdc. Division factor: 2 to 4096 in 12 binary steps. 2, 4, 8, 16, 32, 64, 128, 256, 512, 1024, 2028, 4096. Input: 5~30Vdc, square wave. (max 100kHz) Output: Open collector 30Vdc, 100mA Maximum. Square wave, (max 5kHz) 50:50 mark space ratio.	Hz to Hz Divider www.intech.co.nz/tw-ff
	TWN-FF	Non-isolating frequency input, divided, to sink / source 100mA @ 24Vdc frequency output interface. As above.	

Typical connection for TWN-FF / Non-Isolating

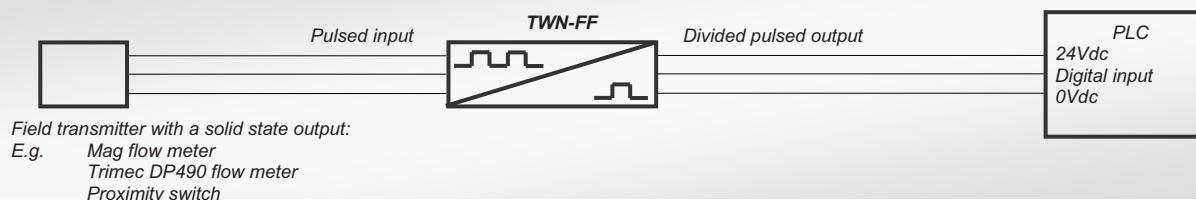

Typical connection for TWI-FF / Isolating

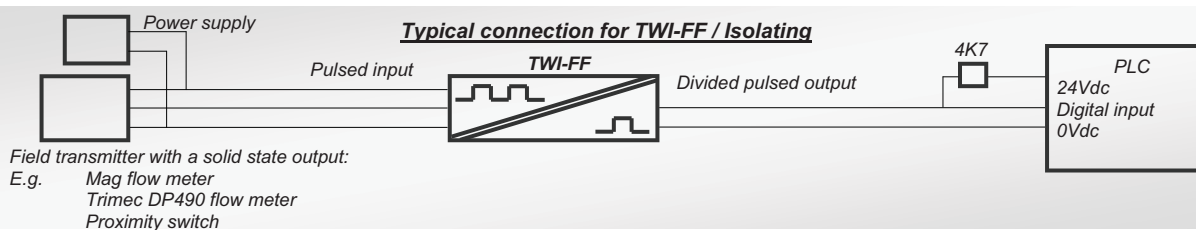

NEW HUMIDITY INDICATOR / TRANSMITTER



- This unit is used with a wet and dry sensor system (e.g. WDT-DW).
- The IN-HWD uses a microprocessor with formulae and look-up tables to obtain better than 1% accuracy for relative humidity over the range of 0~100°C.
- Note: The IN-HWD (rev 2) replaces both the 2100-A4-HWD and the older IN-HWD.

	MODEL	DESCRIPTION	For Ordering Code& Specification:
	IN-HWD	Humidity and Temperature Indicator/Transmitter. <i>Input:</i> 1x wet bulb and 1x dry bulb. Standard: RTD Pt100, 3 wire DIN (0~100°C) <i>Output:</i> 1x humidity and 1x temperature. 2 channels: 4~20mA. <i>Resolution:</i> 0.025% Full scale. 12 bit. <i>Indicator:</i> Dual LED screens for humidity and temp. <i>Standard Power Supply:</i> 85~265Vac / 95~370Vdc.	www.intech.co.nz/in-hwd
	OPTIONS	R4	
	WS232	Serial Port RS232: Includes Modbus RTU.	
	WS485	Serial Port RS485: Includes Modbus RTU.	
	LV	Low Voltage Power Supply: 15~48Vac / 10~72Vdc.	



HUMIDITY WET AND DRY TANK

- Humidity tank with wet and dry sensors.
- For the measurement of relative humidity, RH%.
- Commonly used with the IN-HWD Humidity Indicator / Transmitter.
- Constructed of 316 stainless steel.

	MODEL	DESCRIPTION	For Ordering Code& Specification:
	WDT-DW	Sensors: RTD, Pt100, Band 5. 4.8ø x 150. Others by request. Fill port: 1/8" BSP nipple. Overflow port: 1/8" BSP nipple. Mount: Wall or duct mount. Cable: 4 metres.	www.intech.co.nz/wdt-dw
	WDT-WICK	Spare wick for wet bulb sensor.	

HUMIDITY TRANSMITTERS

- Dual output, 4~20mA loop powered.
- Outputs, %RH and Temp.
- Monolithic IC humidity sensor.
- Pt100 RTD sensor.

	MODEL	DESCRIPTION	For ordering Code& Specification:
	LPN-H-D Rev 1.	Humidity & temperature transmitter, 220mm Duct Mount Dual output, each loop powered. Temperature: 4~20mA = 0~100°C. Humidity: 4~20mA = 0~100%RH.	www.intech.co.nz/lpn-h
	LPN-H-Flange	Optional 100mm flange for LPN-H-D	
	LPN-H-W Rev 1.	Humidity and temperature transmitter, Wall Model Dual output, each loop powered. Temperature: 4~20mA = 0~100°C. Humidity: 4~20mA = 0~100%RH.	

	Calibration canisters for LPN-H	
	LPN-H-75	Calibration canister with 75% RH salt solution.
	LPN-H-43	Calibration canister with 43% RH salt solution.
	LPN-H-33	Calibration canister with 33% RH salt solution.

Calibration system for LPN-H series Humidity sensors

The LPN-H-Ref system is designed to allow *in situ* calibration of LPN-H-W (Rev 1) and LPN-H-D (Rev 1) humidity Transmitters. The LPN-H-Ref system consists of corrosion resistant stainless steel canisters containing humidity regulating salt solutions that replace the black protective filter on the sensor.

Important Note: It is essential that the humidity sensor is mounted vertically with the filter at the bottom to prevent spillage.

PRESSURE TRANSMITTERS

- 4~20mA loop powered.
- Temperature compensation.
- IP67 enclosure.

	MODEL	DESCRIPTION	For Ordering Code & Specification Refer Web Page:
	LPN-DP-100mm	Differential pressure transmitter. 100mm Differential range within ± 20 to ± 125 mm WG.	www.intech.co.nz/lpn-dp
	LPN-DP-250mm	Differential pressure transmitter. 250mm Differential range within ± 100 to ± 250 mm WG.	
	LPN-DP-1000mm	Differential pressure transmitter. 1000mm Differential range within ± 250 to ± 1000 mm WG.	
	LPN-DP-100kPa	Differential pressure transmitter. 100kPa Differential range within ± 40 to ± 100 kPa.	
	LPN-DP-3/15 psi	Pressure transmitter. 3/15 PSI Range, 3 to 15 PSI. Can be used with I/P transducers (3~15PSI output models) for monitoring.	
LPN-DP-Bar	Absolute pressure transmitter. Bar (Atmospheric) Range, 900 to 1100 mbar absolute.		

pH TRANSMITTER

- 4~20mA loop powered.
- LCD display.
- 2kV isolation.
- 0.1% accuracy.
- 40~200mV output test signal.
- LED indication of loop current.
- IP67 enclosure.

	MODEL	DESCRIPTION	For Ordering Code & Specification Refer Web Page:
	LPI-pH	pH voltage to DC isolating transmitter with LCD display. pH milli volt input and Pt100 temperature compensation. Slope and offset adjustments for on-site calibration.	www.intech.co.nz/lpi-ph

For pH probes available for use with the LPI-pH, refer to pages 42 and 43. >>

	0	ACID H ⁺			NEUTRAL 7			ALKALINE OH ⁻			14				
pH	0	1	2	3	4	5	6	7	8	9	10	11	12	13	14
mV at 25°C	+413							0							-413

INSTRUMENT POWER SUPPLIES

PSW-2

The PSW-2 is an isolated switch mode power supply that can supply a wide range of DC output voltages, from 5V to 30V, up to 200mA continuously, and operates over a wide range of input voltages. Due to recent advancements in Switch Mode Power Supply technology, special techniques have been developed that make the PSW-2 both very low noise (typically less than 1mV) and high precision.

Both line and load regulation is better than 0.1% over all conditions (within specified ranges.) These attributes make the PSW-2 better than most comparable linear power supplies, while adding features such as DC input and voltage step-up capability, e.g. 12Vdc input can be stepped up to 24Vdc output (PSW-2-L version).

- Output Adjustable from 5V to 30V.
- Output Current of 200mA.
- Low Noise.
- Precision Regulation.
- Isolated Output Floats Close to Earth Potential.
- Short Circuit Tolerant.
- High Accuracy 0.1%.
- Universal ac/dc Power Supply.
- Compact DIN Rail Mount Enclosure.
- Available Standard or Special Calibration.

	MODEL	DESCRIPTION	For Ordering code & Specifications Refer Web Page:
	PSW-2	Output Voltages: 5, 8, 9, 10, 12, 15, 24, 30, Special. Input Power Supplies: High (100~264Vac). Medium (23~90Vdc).	www.intech.co.nz/psw-2
	PSW-2-L	12~28Vac / 10~30Vdc input.	

PSW-10

The PSW-10 is an isolated switch mode power supply that can supply a wide range of DC output voltages, from 5V to 30V, up to 1A continuously, and operates over a range of input voltages. Due to recent advancements in Switch Mode Power Supply technology, special techniques have been developed that make the PSW-10 both very low noise (typically less than 1mV) and high precision.



Both line and load regulation is better than 0.1% over all conditions (within specified ranges). These attributes make the PSW-10 better than most comparable linear power supplies.

- Output Adjustable from 5V to 30V.
- Output Current of 1A.
- Low Noise.
- Precision Regulation.
- Isolated Output Floats Close to Earth Potential.
- Short Circuit Tolerant.
- High Accuracy 0.1%.
- Universal ac/dc Power Supply.
- Compact DIN Rail Mount Enclosure.
- Available Standard or Special Calibration.

	MODEL	DESCRIPTION	For Ordering code & Specifications Refer Web Page:
	PSW-10	Output Voltages: 5, 8, 9, 10, 12, 15, 24, 30, Special. Input Power Supply: 100~264Vac.	www.intech.co.nz/psw-10

New INSTRUMENT POWER SUPPLY

The PSW-2-F is designed differently from a general purpose power supply. Emphasis is placed on withstanding and rejecting EMI events. The PSW-2-F is an isolated switch mode power supply with an output voltage of 24Vdc and up to 200mA continuously. Due to advancements in Switch Mode Power Supply technology, special techniques have been developed that make the PSW-2-F both very low noise (typically less than 4mV) and high precision. Both line and load regulation is better than 0.1% over all conditions. These attributes make the PSW-2-F better than most comparable linear power supplies.

	MODEL	DESCRIPTION	For Ordering Code & Specification Refer Web Page:
	PSW-2-F	<ul style="list-style-type: none"> • Powers up to 10x 4~20mA 2-wire loops. • Better than most comparable linear supplies. • Overload protection. • Low noise. • High accuracy 2%. • Precision regulation. • Isolated output floats close to earth potential. • Short circuit tolerant. • Compact DIN rail mount enclosure. • Low cost. Output: 24Vdc, 200mA. Input Power Supply: 85~265Vac/dc.	 www.intech.co.nz/psw-2-f

HAND HELD SIGNAL GENERATOR

	MODEL	DESCRIPTION	For Ordering Code & Specification Refer Web Page:
	IN-GEN	<ul style="list-style-type: none"> • Multifunction generator. • Outputs instrument signals. • Use with your own multimeter. Power supply: 9 volt battery. 50~150 ohms: Simulates Pt100, (-100~100°C). 0~20mA: Simulates 0~20mA. Max 320 ohms. 0~100mV: Simulates thermocouple signals. 0~8 volts: Simulates 0~8 volts.	www.intech.co.nz/in-gen

OVER VOLTAGE PROTECTION UNIT

	MODEL	DESCRIPTION	For Ordering Code & Specification Refer Web Page:
	LPN-OVP (Rev 1)	<ul style="list-style-type: none"> • Over Voltage protection unit for instrument signals. • Used extensively for lightning protection. Leakage Current: 10µA @ 24Vdc. Transient cut-off voltage: 33V. Added line resistance: 4 ohms for the loop. Standard DIN rail mount.	www.intech.co.nz/lpn-ovp

LIGHT INTENSITY TRANSMITTER

The TWN-LUX incorporates a silicon photodiode light sensor, in a hermetical sealed case, especially designed for high precision linear applications. The sensor has a flat glass window with a built in colour correction filter, giving an approximation to the spectral response in the human eye.

	MODEL	DESCRIPTION	For Ordering Code & Specification Refer Web Page:
	TWN-LUX	Light intensity transmitter. Power supply: 12~24Vdc. Range: 0~1000 lux, adjustable to 0~10 lux. Dual outputs: 1 x 4~20mA and 1 x 0~10Vdc.	www.intech.co.nz/twn-lux

New! MULTIFUNCTION INDICATOR



The IN-P is a **Multifunction Indicator** which not only interfaces smoothly with a wide range of PLC and monitoring systems, but also as a stand alone unit for single and multi input Indication - Alarm - Control.



- Simple setup and calibration.
- On Screen Step by Step Instructions.
- 5 Buttons for easy Operator Interface.
- Option to add up to 6 Relay Outputs.
- Analogue Output Retransmission option.
- Serial RS485/RS232 port option with Modbus RTU.
Ethernet port option with Modbus TCP.
- Wide Range of Power Supply options from 10V to 265V.
- Multiple functions available for customising to your application.



MODEL	DESCRIPTION	For Ordering Code & Specification Refer Web Page:
IN-P	Multifunction Indicator. 6 Digit LED Display. 6 Set Points. Standard Power Supply: 85~265Vac / 95~370Vdc.	www.intech.co.nz/in-p
PRC1	1x 4~20mA / 0~10V input + 24Vdc excitation.	
PRC4	4x 4~20mA input + 24Vdc excitation.	
TC1	1x Thermocouple input: Types B, J, K, N, R, S, T.	
TC4	4x Thermocouple input: Types B, J, K, N, R, S, T.	
RTD1	1x RTD Pt100 input.	
RTD4	4x RTD Pt100 input.	
OPTIONS		
R2	2x 5A Relay Outputs.	
R4	4x 5A Relay Outputs.	
R6	6x 5A Relay Outputs.	
A	Analogue Output Retransmission: 4~20mA and 0~10V.	
WS232	Serial Port RS232: Includes Modbus RTU.	
WS485	Serial Port RS485: Includes Modbus RTU.	
WEM/WEA	Ethernet Port: Ascii or Modbus TCP.	
LV	Low Voltage Power Supply: 15~48Vac / 10~72Vdc.	
FUNCTIONS (Available on request)		
A	Auto or manual scanner with alarms.	
B	Maths functions, (i) $\sqrt{\quad}$, (ii) Difference, (iii) Average, (iv) Hi / Lo Select.	
C*	Hold, Tare, Reset (External switches connect to rear terminals).	
D*	Flow Rate + Totalising.	
E*	Energy display & totaliser (flow x ΔT).	
F	Step controller.	
G*	Auto / Manual Station.	
H	Retransmission.	
I	Other Functions – please specify.	
J	Data Logging.	

* Available on channel one only.

New PROCESS INDICATORS



- Simple setup and calibration.
- On Screen Step by Step Instructions.
- 5 Buttons for easy Operator Interface.
- Options to add up to 4 Relay Outputs.
- Analogue Output Retransmission option.
- Serial RS485/RS232 port option with Modbus RTU (excluding IN-R).
- Wide Range of Power Supply options from 10V to 265V.

	MODEL	DESCRIPTION	For Ordering code & Specifications Refer Web Page:
	IN-R	Large Display Tachometer Indicator. 4 Digit Large LED Display. Microprocessor Based for Wide Range Calibration. Inputs: 0~30V, magnetic pickup, NPN, PNP, TTL, Namur 4 Set Points with delay. 4 LED's for Alarm indication. Standard Power Supply: 85~265Vac / 95~370Vdc.	www.intech.co.nz/in-r
	IN-RT	Flow Rate Indicator with Totaliser. 6 Digit LED Display. Inputs: 0~30V, magnetic pickup, NPN, PNP, TTL, Namur 4 Set Points with delay. Standard Power Supply: 85~265Vac / 95~370Vdc.	www.intech.co.nz/in-rt
	IN-RTB	Flow Rate and Batching Controller. Dual 6 Digit LED Displays. View Flow Rate & total simultaneously. Inputs: 0~30V, magnetic pickup, NPN, PNP, TTL, Namur 5 Set Points annunciator LED's. Standard Power Supply: 85~265Vac / 95~370Vdc.	www.intech.co.nz/in-rtb
OPTIONS	R2	2x 5A Relay Outputs.	
	R4	4x 5A Relay Outputs.	
	A	Analogue Output Retransmission. Available in 4~20mA and 0~10V.	
	WS232	Serial Port RS232: Includes Modbus RTU. Note: Not available for the IN-R.	
	WS485	Serial Port RS485: Includes Modbus RTU. Note: Not available for the IN-R.	
	LV	Low Voltage Power Supply: 15~48Vac / 10~72Vdc.	

LOOP POWERED INDICATOR

LPI-LCD-5 - Panel Mount Indicator. Loop powered

	MODEL	DESCRIPTION	For Ordering code & Specifications Refer Web Page:
	LPI-LCD-5	Panel mount. Loop powered. Input: 4~20mA, 2 wire. Display: 5-digit LCD of 12.5mm height. Volts Drop: 3.9V @ 20mA. Scaling: Programmable between -19999 to 30000 Max Resolution: 50,000 counts. Accuracy: ±0.02% of reading plus 2 digits. Decimal Point: Programmable to six positions. Temperature: -10°C to +50°C. Protection: IP65. Housing: Plastic. 96 x 48mm.	www.intech.co.nz/lpi-lcd
	Cover	Option: Splash proof lockable security cover, IP65.	

PLC ANALOGUE INPUT EXPANSION

Two 16 channel input Multiplexers to choose from:

1. 2100-M analogue input multiplexer

16 analogue inputs.
High accuracy 0.1%.
Field programmable ranges within each model.

2100-M-R = RTD any span.

2100-M-I = mA any span.

2. 2100-A16 intelligent multiplexer

16 individually configurable inputs.
Pt100 or Pt1000*.
Thermocouple most types/most spans.
mA all ranges.
mV V.
Modbus RTU / Modbus TCP.

Channel select by PLC is the same for both multiplexers:

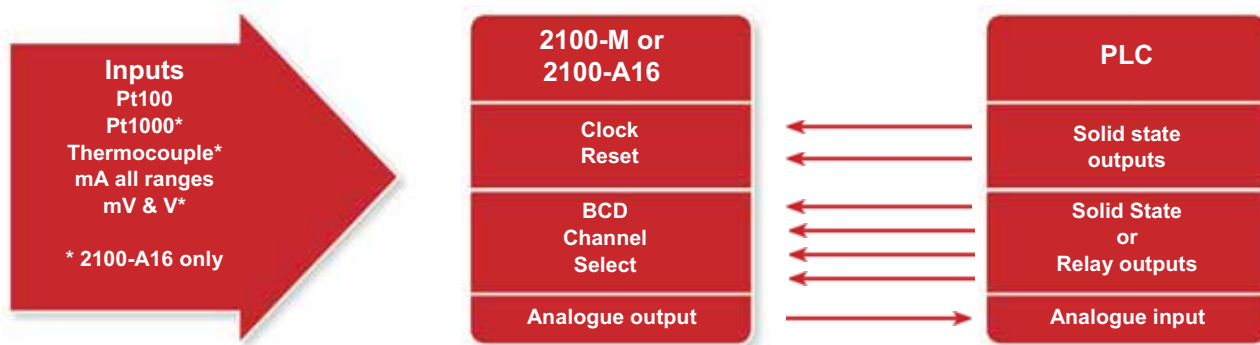

MODEL	PLC CHANNEL SELECT		COMMUNICATIONS			PROGRAMMABLE INPUTS		POWER SUPPLY	
	CLOCK-RESET	BCD	MICROSCAN RS485 RS422	MODBUS RTU (RS485)	MODBUS TCP (Ethernet Option)	UNIVERSAL INPUTS	FIXED INPUT TYPE PROGRAMMABLE RANGE	12/24Vac/dc	110/240Vac
2100-A16	✓	✓	✓	✓	✓	✓		✓	✓
2100-M	✓	✓					✓	✓	✓

ANALOGUE INPUT MULTIPLEXER

- 16 single ended inputs.
- Field programmable input ranges.
- Field programmable output signals.
- Universal power supply: Standard: 85~264Vac/dc or 23~90Vdc (Field selectable). Optional: 10~28Vac/dc.
- 0.1% accuracy.
- Inputs: RTD, Milli-amps.
- Channel stepping mode, 'clock/reset' or 'binary', is field programmable.
- DIN rail mount.

MODEL	DESCRIPTION	For Ordering Code & Specification Refer Web Page:
2100-M-R	RTD inputs. Standard input DIN Pt100. Others by request. Programmable input ranges within 200~0~20 to 600°C. Programmable output, 8 ranges within 0~20mA and 0~10Vdc.	www.intech.co.nz/2100-m
2100-M-I	Milli-amp inputs. Programmable input ranges within 0~2 to 20mA. Programmable output, 8 ranges within 0~20mA and 0~10Vdc.	
OPTION		
2100-M-x-L	Low voltage power supply 10~28Vac/dc.	

Please Note: Modbus Protocols are NOT available with the 2100-M.
If you require a multiplexer with Modbus Protocols please view the 2100-A16 on page 19. >>

PLC INTELLIGENT MULTIPLEXER

- Each input is user selectable in MicroScan software to any of the following:
Thermocouple, RTD (Pt100/Pt1000), mA, mV, volts.
- 16 analogue differential inputs, (RTD single ended).
- 2 relay outputs, for control or alarm functions.
- 2 analogue outputs.
- 4 isolated digital inputs.
- Comms – RS485 or RS422 selectable, RS232 optional. MODBUS-RTU Standard.
- Channel selection: 'binary' or 'clock/reset', selectable.
- 0.1% accuracy.
- DIN rail mount.

MODEL	DESCRIPTION	For Ordering Code & Specification Refer Web Page:
2100-A16	<p>Intelligent analogue input multiplexer. 16 channels.</p> <p><u>Analogue input ranges</u>, scaled within the following span limits: mV. 0~25mV to ±500mV. volts. 0~1V to ±15Vdc. mA. 0~1mA to ±100mA. (4~20mA default). RTD. 0~25°C to -200~850°C. Pt100/Pt1000 selectable. RTD inputs must be either Pt100 or Pt1000 not a mixture. Thermocouple. K, J, N, T, R, S, B, E, with CJC. Range must be within -200~0~1800°C.</p> <p><u>Resolution:</u> 16 bit. <u>Differential:</u> 18 volts maximum. <u>Power supply:</u> 85~264Vac/dc or 23~90Vdc, selectable. 10~28Vac/dc, optional.</p> <p>PLC control <u>Channel select:</u> Clock/reset or binary selectable. <u>Analogue output:</u> 1 only, 4~20mA, 0~20mA, selectable. 0~10Vdc, 2~10Vdc, factory option.</p> <p>Computer control <u>Analogue output:</u> 1 only, 4~20mA, 0~20mA, selectable. 0~10Vdc, 2~10Vdc, factory option. <u>Relay outputs:</u> 2 only, N/O contacts. Rating, 1 Amp 30Vac/dc.</p> <p><u>Comms:</u> Isolated RS485 (2 wire), RS422 (4 wire), selectable. RS232, optional. Modbus RTU standard. <u>Baud rate:</u> 9600, 4800, 2400, selectable.</p>	<p>www.intech.co.nz/2100-a16</p>  <p>PLC</p> <p>2100-A16 Intelligent Multiplexer</p> <p>Additional multiplexers</p>
OPTIONS		
2100-A16-RS232	RS232 option fitted to 2100-A16 (Supplied with 5 metres cable)	
2100-A16-L	Power supply of 10~28Vac/dc fitted.	

The MicroScan system and the PLC can access the 2100-A16 multiplexer at the same time.

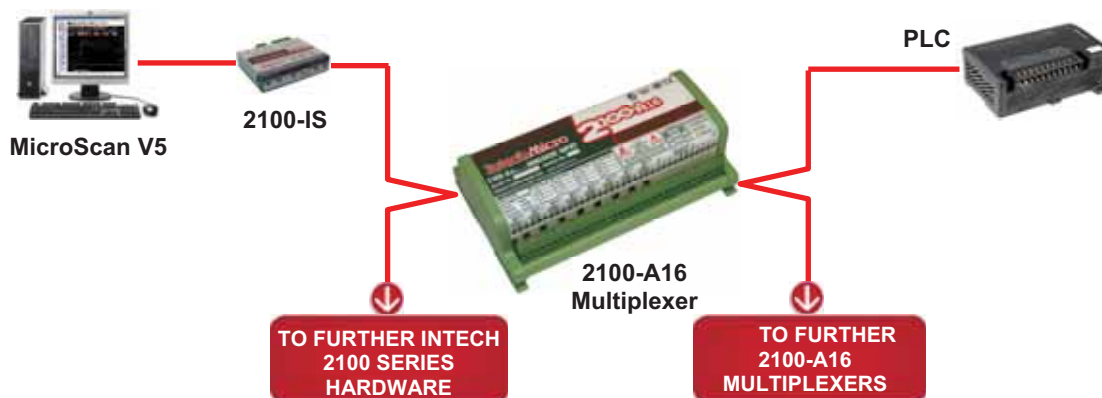

PLC ANALOGUE OUTPUT EXPANSION UNIT

- Field station with 8 analogue outputs.
- Analogue output resolution: 4, 8 or 12 bit, selectable.
- DIN rail mount.
- Comms – RS485 or RS422 selectable, RS232 optional.
- Channel selection: 'binary' or 'clock/reset', selectable.
- Easy programming via the comms port.

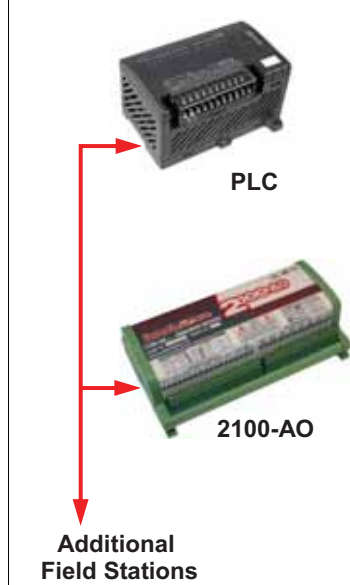
MODEL	DESCRIPTION	For Ordering Code & Specification Refer Web Page:
2100-AO	<p>Field station. 8 analogue outputs. This is the 2100-AO unit used as an output expander for PLC systems</p> <p><u>Analogue output ranges:</u> (8 channels) mA. 4~20mA, 0~20mA, selectable. volts. 0~10Vdc, 2~10Vdc, factory option.</p> <p><u>Analogue input ranges:</u> (1 channel. Signal from the PLC). mA. 4~20mA, 0~20mA, selectable. volts. 0~10Vdc, 2~10Vdc, factory option.</p> <p><u>Resolution:</u> 4, 8 or 12 bit, selectable.</p> <p><u>Channel selection:</u> Binary or clock/reset.</p> <p><u>Power supply:</u> 85~264Vac/dc or 23~90Vdc, selectable. 10~28Vac/dc, optional.</p> <p><u>Comms:</u> Isolated RS485 (2 wire), RS422 (4 wire), selectable. RS232 optional.</p> <p><u>Baud rate:</u> 9600, 4800, 2400, selectable.</p>	<p>www.intech.co.nz/2100-ao</p>  <p>PLC</p> <p>2100-AO</p> <p>Additional Field Stations</p>
OPTIONS		
2100-AO-RS232	RS232 option fitted to the 2100-AO (Supplied with 5 metres cable).	
2100-AO-L	Power supply of 10~28Vac/dc.	
2100-AO-VIO	Analogue input / output signal of 0~10Vdc, 2~10Vdc.	

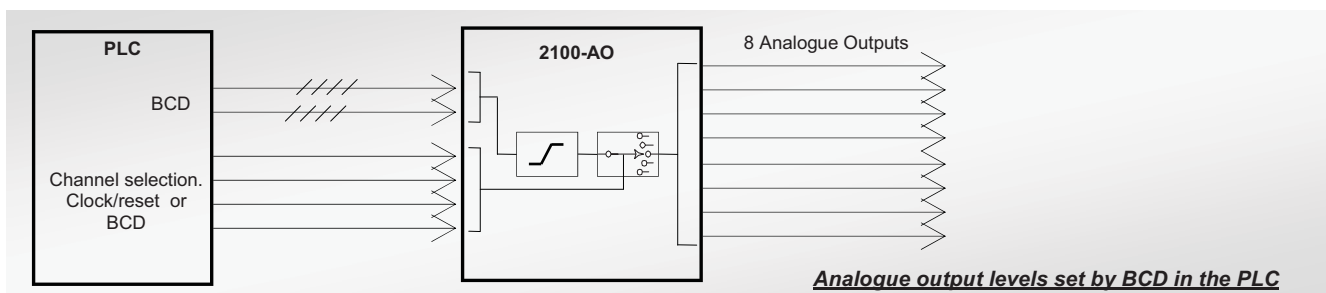
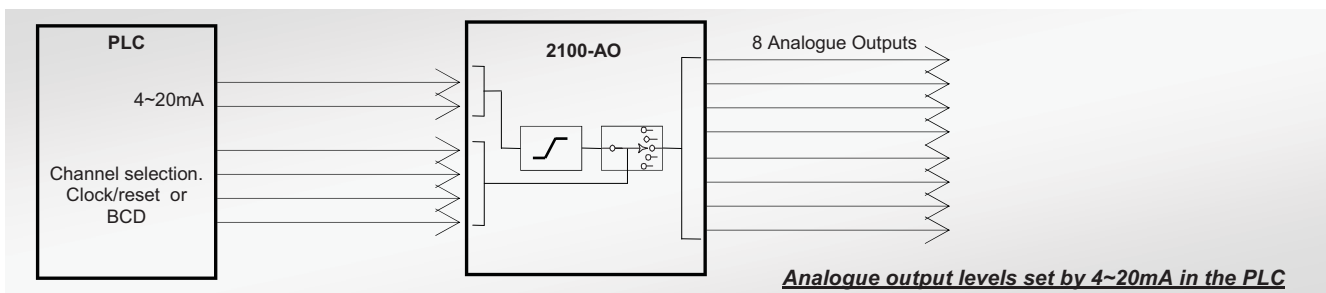

COMMS CONVERTERS

- The **2100-IS** converts and isolates RS232 from a computer to RS485 or RS422 for communication to data high-way stations.
- Internal audible and relay output alarm for communication failure.
- Desk top module, complete with serial cable and power cord.
- Radio modem compatible.



	MODEL	DESCRIPTION	For Ordering Code & Specification:
	2100-IS	RS232 to RS485 or RS422 (selectable) converter, Isolating. <u>Comms baud rate:</u> 9600 (default), 19200, 4800 (optional). <u>Relay output:</u> 1 relay, change over. Rating, 1 Amp, 24Vdc. <u>Power supply:</u> 9V plug pack, (supplied with 2100-IS).	www.intech.co.nz/2100-is
	OPTIONS	Adaptor kits for modems etc also available. Please contact us.	

- The **2100-NS** converts RS232 from a computer to RS422/RS485 for communication to data high-way stations.

	MODEL	DESCRIPTION	For Ordering Code & Specification:
	2100-NS	RS232 to RS422/RS485 converter Kit. Non-isolating. <u>Comms baud rate:</u> 9600 (default), 4800, 2400 (optional). <u>Power supply:</u> 9 volt plug pack, (supplied with 2100-NS).	www.intech.co.nz/2100-ns

- The **USB485** converts USB from a computer to RS485 for communication to data high-way stations.
- Only use for temporary monitoring, for industrial environments we recommend using a physical RS232 connection.

	MODEL	DESCRIPTION	For Ordering Code & Specification:
	USB485	USB to RS485 converter, Non-isolating. Powered from computer USB powered port. 3m length.	www.intech.co.nz/usb485

	MODEL	DESCRIPTION	For Ordering Code & Specification:
	2100-NET	Ethernet TCP/IP to serial converter. Isolating. <u>Comms baud rate:</u> RS422 / 485 / 232, (Software Selectable) 19200, 9600, 4800. <u>Power supply:</u> 85~264Vac/dc, 50/60Hz, 10VA. 23~90Vdc, 10VA. 10~28Vac/dc, 50/60Hz, 10VA.	www.intech.co.nz/2100-net 

2300 SERIES I/O REMOTE STATIONS & PLC

Analogue and Digital Input/output stations - Low cost - Connects to MicroScan V5 software

- Low Cost I/O Remote Stations.
- MODBUS RTU with MODBUS TCP option.
- MicroScan V5 Compatible - Seamless Integration.
- Also ideal for use when inputs/outputs are required for a PLC and Modbus comms are available.
- Plug-in connectors makes replacement easy.
- Programmable Ranges within input type.
- 1.0 kV or greater Isolation.
- 0.2% Accuracy (12 Bit).
- Compact DIN rail mount Enclosure.
- LEDs indicate I/O status plus comms and Power Supply.
- Comms Fail Alarm (optional).
- Power Supply: 24Vdc.



MODEL	DESCRIPTION	For Ordering Code & Specification Refer Web Page:
2300-A8I	8 x 4~20mA inputs. Single ended (all input negatives internally connected). 0~20mA inputs programmable / 250 ohms input resistance. 1.5KV isolation between inputs and power supply and comms (RS485). Power Supply = 24Vdc @ 30mA typical. Requires an independent and isolated P/S to power logic inputs.	www.intech.co.nz/2300 4~20mA inputs Commoned
2300-A8II	8 x 4~20mA inputs , Isolated 1.0KV isolation between each input. 0~20mA inputs programmable / 250 ohms input resistance. 1.5KV isolation between inputs and power supply and comms (RS485). Power Supply = 24Vdc @ 40mA typical.	4~20mA inputs Isolated
2300-A8VI	8 x Voltage inputs , Isolated 1.0KV isolation between each input. 0~10V or 2~10V inputs programmable / 20 Kohms input resistance. 1.5KV isolation between inputs and power supply and comms (RS485). Power Supply = 24Vdc @ 40mA typical.	Volts inputs Isolated
2300-Tc8	8 x Thermocouple & mV inputs. Isolated 350V peak isolation between each input. Programmable inputs type K, J, T, E, N, B, S, R, with CJC. Programmable mV inputs 0~50mV, -100~100mV. 1.5KV isolation between inputs and power supply and comms (RS485). Power Supply = 24Vdc @ 40mA typical.	Thermocouple & mV Isolated
2300-RTD6	6 x RTD inputs , Pt100, Pt1000, Ni120, Ni1000. 1.5KV isolation between inputs and power supply and comms (RS485). Resolution = 0.1°C / Power Supply = 24Vdc @ 55mA typical.	RTD input
2300-MULTI	6 x combination analogue inputs , single ended. 2 x RTD inputs, 2 x 4~20mA inputs, 2 x Voltage inputs. 1 x 4~20mA output, 4 x Digital inputs, 2 x Digital outputs. 1.5KV isolation between inputs and power supply and comms (RS485). Power Supply = 24Vdc @ 70mA typical.	Combination Inputs and Outputs
2300-D16	16 x Digital inputs. Input voltage: 12~24Vdc. 1.5KV isolation between inputs and power supply and comms (RS485). Power Supply = 24Vdc @ 30mA typical.	Digital inputs
2300-RO4	4 x Relay outputs , Change over contacts. Contact rating: 240Vac @ 0.5A, 28Vdc @ 1A. 1.0KV isolation between inputs and power supply and comms (RS485). One output can be dedicated to Comms Fail Alarm. Power Supply = 24Vdc @ 100mA typical.	Relay outputs
24Vdc Power Supply Options:		
PSW-2-F	Output Voltage: 24Vdc. Max current: 200mA continuous. Input Power Supply: 85~265Vac/dc.	 www.intech.co.nz/psw-2-f
PSW-10-X	Output Voltage: 24Vdc. Max Current: 1 Amp continuous. Input Power Supply: 100~264Vac.	

2300 SERIES I/O REMOTE STATIONS

Examples of connectivity - RS485 data Hi-Way

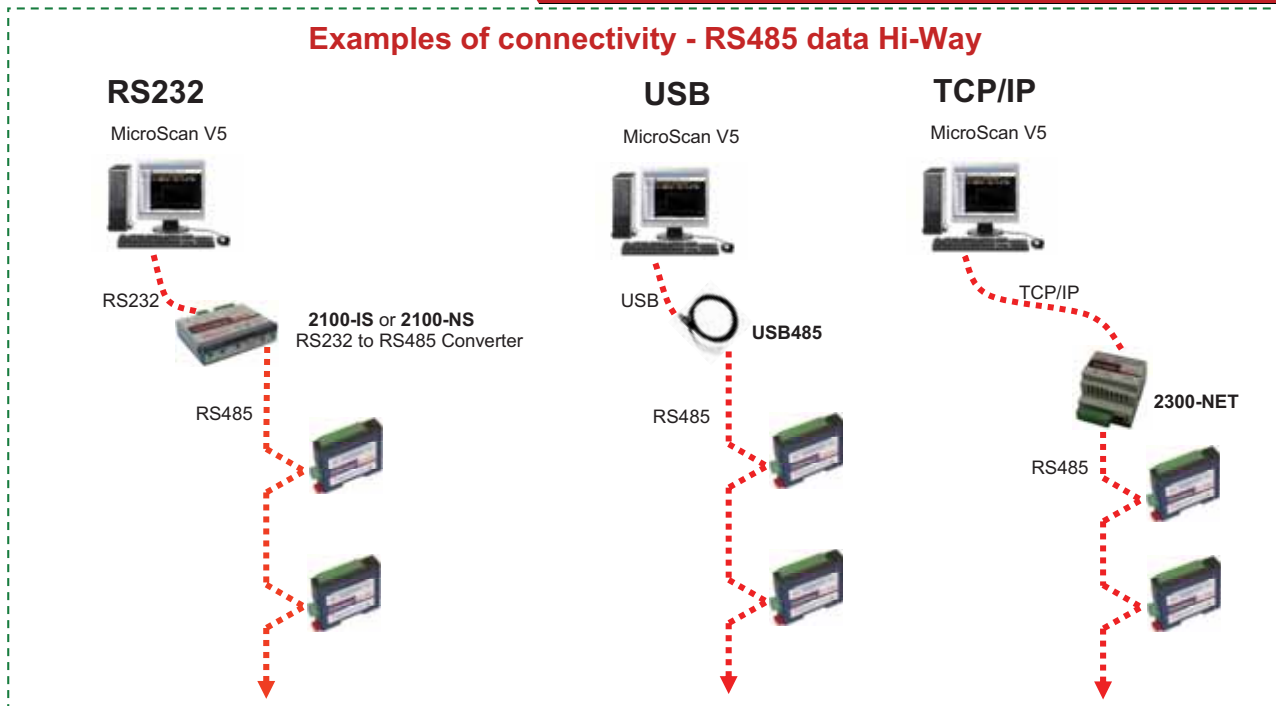

RS232 Converter Isolating - Alarm for communication failure

- The 2100-IS and 2100-NS converts RS232 from a computer to RS485 for communication to the 2300 series stations.

	MODEL	DESCRIPTION	For Ordering Code & Specification:
	2100-IS	RS232 to RS485 Isolating Converter. Comms baud rate: 9600. Relay output: 1 relay, change over. Rating, 1Amp, 24Vdc. Power supply: 9V plug pack (supplied with 2100-IS). Internal audible and relay output alarm for communication failure.	www.intech.co.nz/2100-is

RS232 Converter Kit Non-Isolating

	MODEL	DESCRIPTION	For Ordering Code & Specification:
	2100-NS	RS232 to RS485 converter kit, Non-isolating. Comms baud rate: 9600. Power supply: 9 volt plug pack (supplied with 2100-NS).	www.intech.co.nz/2100-ns

USB to RS485 Converter

	MODEL	DESCRIPTION	For Ordering Code & Specification:
	USB485	USB to RS485 converter, Non-isolating. Powered from computer USB powered port. 3m length. <i>Note:</i> Only use for temporary monitoring, for industrial environments we recommend using a physical RS232 connection.	www.intech.co.nz/usb485

TCP/IP to RS485 Converter Isolating

- The 2300-NET converts Ethernet TCP/IP to RS485 for communication to the 2300 series stations.

	MODEL	DESCRIPTION	For Ordering Code & Specification:
	2300-NET	Ethernet TCP/IP to RS485 Converter, Isolating. Comms baud rate: 9600. Power supply: 24Vdc. Modbus TCP to Modbus RTU. Compact DIN rail mount Enclosure.	www.intech.co.nz/2300-net
	PSW-2-F	If you require a 24Vdc Power supply for the 2300-NET.	

DIGITAL I/O STATION

Intech Micro 2100 Series - Data high-way Remote Stations

- Remote station with 12 digital inputs and 12 relay outputs.
- Each input is user selectable in MicroScan software to any of the following:
 - on/off state, flow rate and totalising, counting.
- Comms - RS485 or RS422 selectable, RS232 optional.
- Radio modem compatible.
- DIN rail mount.

MODEL	DESCRIPTION	For Ordering Code & Specification Refer Web Page:
2100-D	<p>Digital input/output remote station.</p> <p><u>Digital inputs:</u> 12 opto isolated, 5-30Vdc, 500Hz max. (max count: 16383, then resets).</p> <p><u>Relay outputs:</u> 12 relays. Rating, 2 Amp, 30Vdc/250Vac. (10 c/o and 2 n/o contacts).</p> <p><u>Power supply:</u> 85~264Vac/dc or 23~90Vdc, selectable. 10~28Vac/dc, optional.</p> <p><u>Comms:</u> Isolated RS485 (2 wire), RS422 (4 wire), selectable. RS232 optional.</p> <p><u>Baud rate:</u> 9600, 4800, 2400, selectable.</p>	<p>www.intech.co.nz/2100-d</p>  <p>2100-D</p>
OPTIONS		
2100-D-RS232	RS232 option fitted to 2100-D. (Supplied with 5 metres cable).	
2100-D-L	Power supply of 10~28Vac/dc fitted.	

RELAY EXPANSION UNIT

- The 2100-R2 plugs into either the 2100-A16 or the 2100-A4 to expand the number of relay outputs.
- 16 relay outputs. Can use 2x 2100-R2 with the 2100-A16 rev 1.3 or a total 32 relay outputs!
- DIN rail mount.

	MODEL	DESCRIPTION	For Ordering Code & Specification Refer Web Page:
	2100-R2	<p>Relay output expansion unit.</p> <p><u>Relay outputs:</u> 16 relays, change over contacts. Rating, 2 Amp, 30Vdc / 230Vac.</p> <p><u>Power supply:</u> 85~264Vac/dc or 23~90Vdc, selectable. 10~28Vac/dc, optional.</p>	<p>www.intech.co.nz/2100-r2</p>
	OPTION		
	2100-R2-L	Power supply of 10~28Vac/dc fitted.	

Intech Micro 2100 Series - Data high-way Remote Stations

- Remote station with:
 - 8 analogue outputs.
 - 8 analogue inputs.
 - 12 digital inputs.
 - 2 relay outputs.
- Comms - RS485 or RS422 selectable, RS232 optional.
- 12 bit resolution.
- Universal ac/dc power supply.
- Radio modem compatible.
- Easy programming by MicroScan maps.
- Programmable station number.
- Four of the digital inputs are user selectable in MicroScan software to any of the following:
 - on/off state,
 - flow rate and totalising,
 - counting (max 50 Hz).

MODEL	DESCRIPTION	For Ordering Code & Specification Refer Web Page:
2100-AO	<p>Analogue and Digital I/O Remote Station.</p> <p>Analogue input and output. Digital input and relay output.</p> <p><u>Analogue input ranges:</u> mA. 0~20mA, 4~20mA, selectable. volts. 0~10Vdc, 2~10Vdc, factory option.</p> <p><u>Analogue output selectable ranges:</u> mA. 0~20mA, 4~20mA, selectable. volts. 0~10Vdc, 2~10Vdc, factory option.</p> <p><u>Digital inputs:</u> 12 opto isolated, 5~30Vdc. 4 of which can be used for counting (50 Hz max). (max count: 16383, then resets).</p> <p><u>Relay outputs:</u> 2 relays. Rating, 2 amp, 30Vdc/250Vac. (n/c or n/o contacts, selectable).</p> <p><u>Power supply:</u> 85~264Vac/dc or 23~ 90Vdc, selectable. 10~28Vac/dc, optional.</p> <p><u>Comms:</u> Isolated RS485 (2 wire), RS422 (4 wire), selectable. RS232, optional.</p> <p><u>Baud rate:</u> 9600, 4800, 2400, selectable.</p>	<p>www.intech.co.nz/2100-ao</p>  <p>2100-AO</p>
OPTIONS		
2100-AO-RS232	RS232 option fitted to 2100-AO. (Supplied with 5 metres cable).	
2100-AO-L	Power supply of 10~28Vac/dc fitted.	

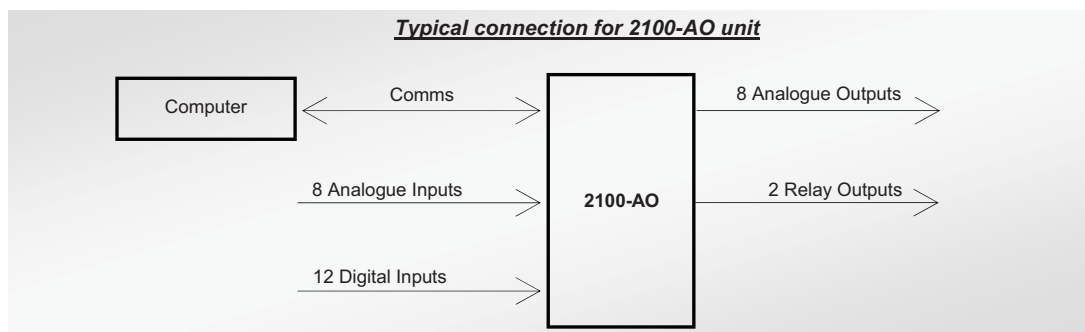

ANALOGUE INPUT STATION

Intech Micro 2100 Series - Data high-way Remote Stations

- Each input is user selectable in MicroScan software to any of the following:
Thermocouple, RTD, mA, mV, volts.
- 16 analogue differential inputs, (RTD single ended).
- 4 digital inputs, for counting or on/off status.
- 2 relay outputs, for control or alarm functions.
- 2 analogue outputs.
- Comms – RS485 or RS422 selectable, MODBUS-RTU Standard, RS232 / Ethernet TCP/IP optional.
- Input expansion, up to four 16 input 2100-M units.
- Output expansion, up to two 16 relay 2100-R2 units.
- Radio modem compatible.
- 16 resident 'computer free' on board controllers.
- Use with the two on board relays or the 2100-R2 unit.

MODEL	DESCRIPTION	For Ordering Code & Specification Refer Web Page:										
2100-A16	<p>Analogue input remote station. 16 channels.</p> <p><u>Analogue input ranges:</u> scaled within the following span limits:</p> <table> <tr> <td>mV.</td> <td>0~25mV to ±500mV.</td> </tr> <tr> <td>volts.</td> <td>0~1Vdc to ±15Vdc.</td> </tr> <tr> <td>mA.</td> <td>0~1mA to ±100mA. (4~20mA default).</td> </tr> <tr> <td>RTD</td> <td>0~25°C to -200~850°C. Pt100/Pt1000 selectable. RTD inputs must be either Pt100 or Pt1000 not a mixture.</td> </tr> <tr> <td>Thermocouple</td> <td>K, J, N, T, R, S, B, E, with CJC. Range must be within -200~0~1800°C. 16 bit.</td> </tr> </table> <p><u>Resolution:</u> <u>Differential:</u> 18 volts maximum. <u>Digital input:</u> 4 opto isolated, 5~30Vdc, 50Hz max. max count, 16383 and rolls over.</p> <p><u>Analogue outputs:</u> 2 channels. (Not available when Multiplexers are connected). 4~20mA, 0~20mA, selectable. 0~10Vdc, 2~10Vdc, factory option.</p> <p><u>Relay outputs:</u> 2 relays, n/o contacts, Rating, 1 Amp 30Vac/dc.</p> <p><u>Power supply:</u> 85~264Vac/dc or 23~90Vdc, selectable. 10~28Vac/dc, optional (refer below).</p> <p><u>Comms:</u> Isolated RS485 (2 wire), RS422 (4 wire) selectable. Modbus RTU Standard. RS232 / Ethernet TCP/IP optional. (Refer below.)</p> <p><u>Baud rate:</u> 9600, 4800, 2400, selectable. <u>Control:</u> Set points and hysteresis values for the 16 resident on board controllers are downloaded from the MicroScan mimic package software and held in permanent memory.</p>	mV.	0~25mV to ±500mV.	volts.	0~1Vdc to ±15Vdc.	mA.	0~1mA to ±100mA. (4~20mA default).	RTD	0~25°C to -200~850°C. Pt100/Pt1000 selectable. RTD inputs must be either Pt100 or Pt1000 not a mixture.	Thermocouple	K, J, N, T, R, S, B, E, with CJC. Range must be within -200~0~1800°C. 16 bit.	<p>www.intech.co.nz/2100-a16</p> <p>A maximum of 4 multiplexers to each 2100-A16. Each multiplexer uses one of the 2100-A16 16 analogue inputs.</p> <p>www.intech.co.nz/2100-a16-net</p>
mV.	0~25mV to ±500mV.											
volts.	0~1Vdc to ±15Vdc.											
mA.	0~1mA to ±100mA. (4~20mA default).											
RTD	0~25°C to -200~850°C. Pt100/Pt1000 selectable. RTD inputs must be either Pt100 or Pt1000 not a mixture.											
Thermocouple	K, J, N, T, R, S, B, E, with CJC. Range must be within -200~0~1800°C. 16 bit.											
OPTIONS												
2100-A16-NET	Analogue input remote station fitted with Ethernet TCP/IP connection. MicroScan TCP & Modbus TCP protocols.											
2100-A16-RS232	RS232 option fitted to 2100-A16 (Supplied with 5 metres cable).											
2100-A16-L	Power supply of 10~28Vac/dc fitted.											
Expansion notes												
Input	<p>Input expansion: This is a standard feature. Supports up to four 2100-M multiplexers. The two analogue outputs are not available with this option.</p>											
Output	<p>Output expansion: Supports up to two 2100-R2 relay output modules. This unit allows the station to 'stand alone' as a 16 channel controller for a combination of (on/off or heat/cool) control and alarm functions. The heat/cool option utilises 2 relays per channel. The 2100-A16 (Rev 1.3) can now support 16 heat/cool controllers. For this, 32 relay O/P's are required.</p>											

ANALOGUE INPUT STATION

Intech Micro 2100 Series - Data high-way Remote Stations

- Each channel can be any of the inputs and any of the ranges shown below by programming on board links and software selection.
- 4 analogue inputs, single ended, 12 bit resolution.
- 4 digital inputs, for counting or on/off status.
- 4 relay outputs, for control or alarm.
- 2 analogue outputs.
- Comms – RS485 or RS422 selectable.
- Input expansion, up to four 2100-M multiplexers.
- Output expansion of one 2100-R2 (16 relays).
- 4 resident 'computer free' on board controllers.
- Radio modem compatible.

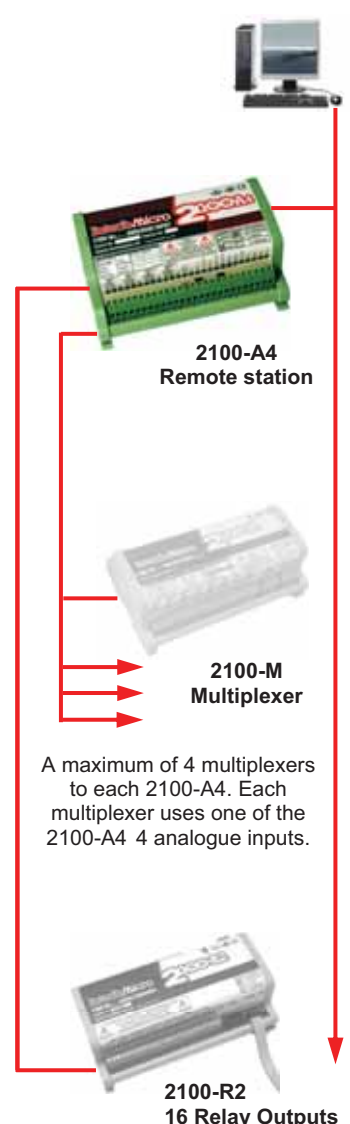
MODEL	DESCRIPTION	For Ordering Code & Specification Refer Web Page:										
2100-A4	<p>Analogue input remote station. 4 channels.</p> <p><u>Analogue input selectable ranges:</u></p> <table style="width: 100%; border-collapse: collapse;"> <tr> <td style="width: 20%;">mV.</td> <td>0~75mVdc, 0~150mVdc, 0~300mVdc.</td> </tr> <tr> <td>volts.</td> <td>0~2.5Vdc, 0~5Vdc, 0~10Vdc.</td> </tr> <tr> <td>mA.</td> <td>0~10mA, 0~20mA, 4~20mA.</td> </tr> <tr> <td>Pt100.</td> <td>-50~140°C, -50~350°C, -50~850°C.</td> </tr> <tr> <td>Thermocouple.</td> <td>K, J, N, T, E, with CJC. Range must be within 100~1300°C.</td> </tr> </table> <p><u>Tx supply:</u> 20Vdc, 80mA.</p> <p><u>Digital inputs:</u> 4 opto isolated, 5-30Vdc, 50Hz max. max count, 16383 and rolls over.</p> <p><u>Relay outputs:</u> 4 relays, c/o contacts, Rating, 2 Amp, 30Vdc / 250Vac.</p> <p><u>Analogue outputs:</u> 2 channels: Selectable: 4~20mA, 0~20mA, 0~10Vdc, 2~10Vdc.</p> <p><u>Power supply:</u> 85~264Vac/dc or 23~90Vdc, selectable.</p> <p><u>Comms:</u> Isolated RS485 (2 wire), RS422 (4 wire), selectable.</p> <p><u>Baud rate:</u> 9600, 4800, 2400, selectable.</p> <p><u>Control:</u> Set points and hysteresis values for the 4 resident on board controllers are downloaded from the MicroScan mimic package software and held in permanent memory.</p>	mV.	0~75mVdc, 0~150mVdc, 0~300mVdc.	volts.	0~2.5Vdc, 0~5Vdc, 0~10Vdc.	mA.	0~10mA, 0~20mA, 4~20mA.	Pt100.	-50~140°C, -50~350°C, -50~850°C.	Thermocouple.	K, J, N, T, E, with CJC. Range must be within 100~1300°C.	<p style="text-align: center;">www.intech.co.nz/2100-a4</p> <div style="text-align: center;">  <p>2100-A4 Remote station</p> <p>2100-M Multiplexer</p> <p>2100-R2 16 Relay Outputs</p> </div> <p>A maximum of 4 multiplexers to each 2100-A4. Each multiplexer uses one of the 2100-A4 4 analogue inputs.</p>
mV.	0~75mVdc, 0~150mVdc, 0~300mVdc.											
volts.	0~2.5Vdc, 0~5Vdc, 0~10Vdc.											
mA.	0~10mA, 0~20mA, 4~20mA.											
Pt100.	-50~140°C, -50~350°C, -50~850°C.											
Thermocouple.	K, J, N, T, E, with CJC. Range must be within 100~1300°C.											

MINIPACKS

Complete Chart Recorder replacement Packages

MINI PACK 8

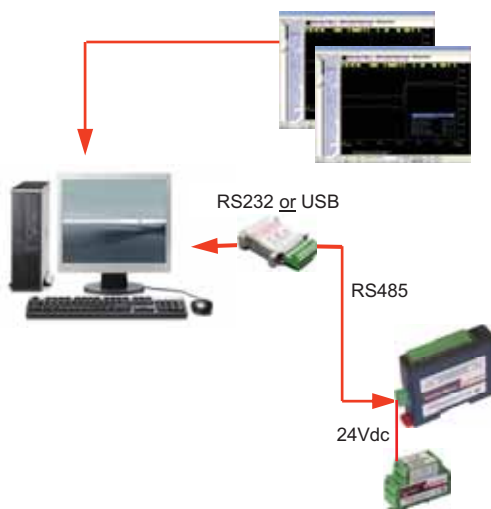

UP TO 8 CHANNELS OF RECORDING

Remote stations available for the following: milli-amperes, milli-volts, Voltage, Thermocouple, RTD, Combination.

<< Refer pages 22/23

SOFTWARE - Supplied with USB Dongle.
1x MICROSCAN V5 RECORDER LITE 8

And HARDWARE

- 1x COMMS CONVERTER RS232 to RS485 {2100-NS} or USB to RS485 {USB485} (for temporary monitoring only) (specify converter type when ordering, RS232 is default).
- 1x INTECH MICRO 2300 Remote Station.
c/w PSW-2-F Power Supply 24Vdc, 200mA.
Specify input type when ordering: Voltage/Current/Thermocouple/RTD/Multi.

Option 1 - If using 2300-RTD6 (6x RTD inputs).

Option 2 - If using 2300-A8I (8x 4~20mA inputs Non-isolated).
Note: Option 2 (2300-A8I) requires an independent and isolated power supply to power logic inputs.

Option 3 - Using any other 2300 I/O remote station.

Upgrade - 2300-RO4 - Comms fail alarm and/or Alarm outputs.

MINI PACK 16

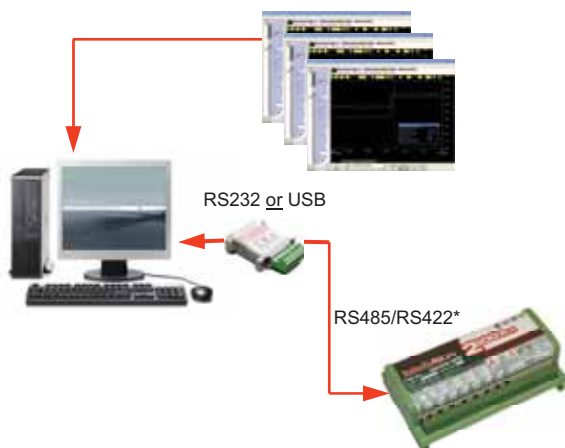

UP TO 16 CHANNELS OF RECORDING

Each input channel can be individually programmed to any of the following: Pt100 or#, Pt1000, Thermocouple, milli-amperes, milli-volts, Voltage.

SOFTWARE - Supplied with USB Dongle.
1x MICROSCAN V5 RECORDER LITE 16

And HARDWARE

- 1x COMMS CONVERTER RS232 to RS485 {2100-NS} or USB to RS485 {USB485} (for temporary monitoring only) (specify converter type when ordering, RS232 is default).
- 1x INTECH MICRO 2100-A16-X.

Upgrade - 1x 2100-IS - Isolated comms converter with Alarm output.

Upgrade - 1x 2100-A16-NET - Connect via Ethernet TCP/IP.

MINI PACK 32

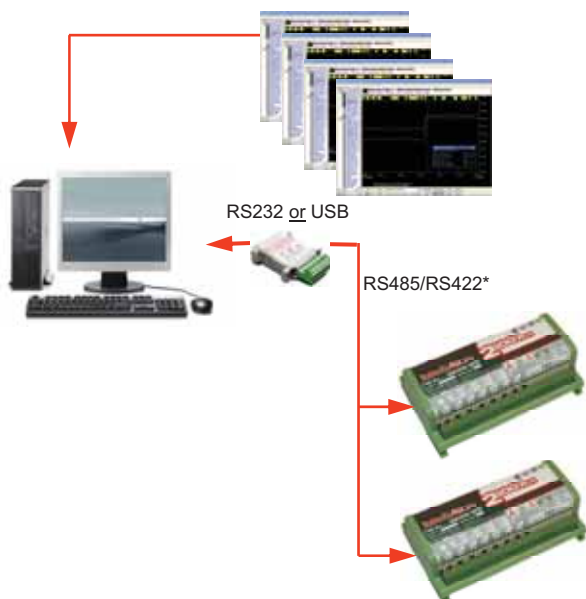

UP TO 32 CHANNELS OF RECORDING

Each input channel can be individually programmed to any of the following: Pt100 or#, Pt1000, Thermocouple, milli-amperes, milli-volts, Voltage.

SOFTWARE - Supplied with USB Dongle.
1x MICROSCAN V5 RECORDER LITE 32

And HARDWARE

- 1x COMMS CONVERTER RS232 to RS485 {2100-NS} or USB to RS485 {USB485} (for temporary monitoring only) (specify converter type when ordering, RS232 is default).
- 2x INTECH MICRO 2100-A16-X.

Upgrade - 1x 2100-IS - Isolated comms converter with Alarm output.

Upgrade - 2x 2100-A16-NET - Connect via Ethernet TCP/IP.

* 2100-A16 RS422 available with 2100-NS/IS RS232 converter only.
2100-A16 RTD inputs must be either Pt100 or Pt1000 not a mixture.

www.intech.co.nz/minipack

INTECH MICRO 2100-SERIES

Schematic Layout

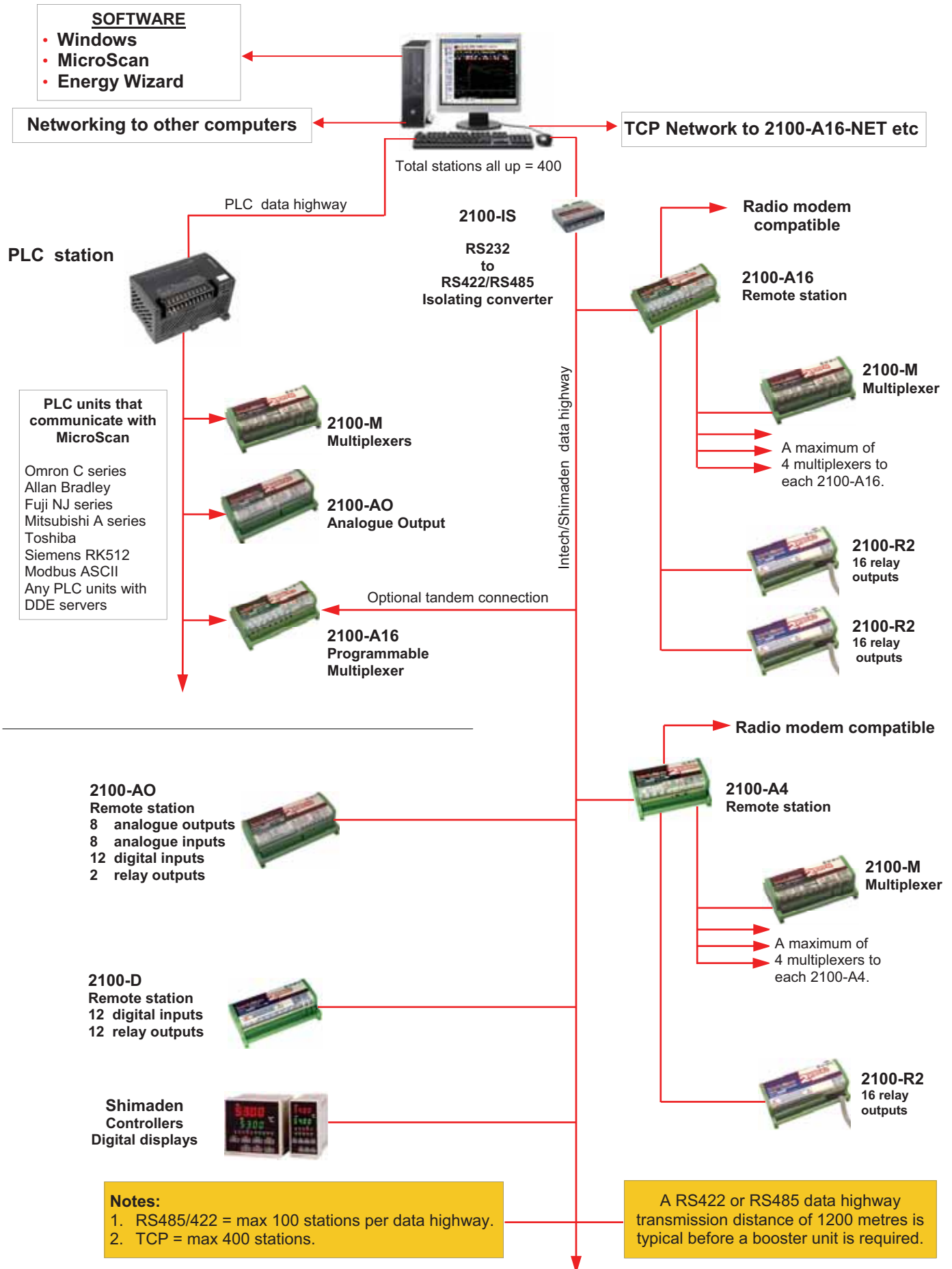

DATA LOGGING AND SCADA SOFTWARE

Recorder Module

- Real-time line graphs.
- Real-time data screens.
- Data analysis.
- Batch recording.
- Continuous recording.
- Mathematical blocks e.g.
 - subtraction -addition
 - multiply -divide
 - Sq root -average
 - min/max -nat. log
- Totalising in engineering units.
- Total hours run facility.
- Data logs to printer.
- ISO 9000 support.
- Data storage to disk.
- Help screens.
- Historical retrieval.
- Historical search.
- History replay.
- Function key support.
- Alarm handling and printing.
- Event handling and printing.
- Comment entry by operators.
- Report generator.
- User log-on and audit.
- DDE support.
- Communicates with:
 - Intech field stations.
 - Most PLC's.
- Multi-level passwords.
- Excel support.
- Cost effective field interface hardware.

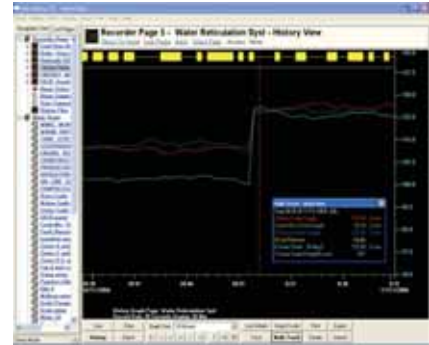

A screenshot of the 'Alarm Log' window. It displays a table with columns for 'Time', 'Alarm', 'Status', and 'Action'. The table contains several rows of data, including timestamps and descriptions of alarm events. The interface includes a search bar and various control buttons.

- MicroScan is a complete Windows based SCADA software product, meeting the demands of industrial, commercial, and research environments.
- Start off small with the world's best 'Recorder Module' for QA, mandatory data collections, plus plant wide monitoring, or jump straight into a full system with Recorder and Mimic (MM1) modules.
- Add the powerful 'Network Module' to share the data with managers, accountants, engineers, and others.



A screenshot of the 'Data Summary' window. It displays a detailed table with multiple columns, including 'Page', 'Name', 'Unit', 'Value', and 'Location'. The table lists various data points from different pages of the system, such as 'Page 4 - Network Oil Road Rate' and 'Page 5 - ENERGY MANAGEMENT'. The data is organized into sections corresponding to different pages.

A screenshot of the 'Alarm Status' window. It displays a table with columns for 'Alarm', 'Status', and 'Action'. The table shows a list of active and inactive alarms, including their descriptions and the time they occurred. The interface includes a search bar and various control buttons.

A screenshot of the 'Recorder Page 6 - ENERGY MANAGEMENT' window. It displays a data summary table with columns for 'Page', 'Name', 'Unit', 'Value', and 'Location'. The table lists various data points from different pages of the system, such as 'Page 6 - ENERGY MANAGEMENT'. The data is organized into sections corresponding to different pages.

Mimic Module

- Live screen graphics.
- PLC operator control.
- Current plant values and configuration.
- **Intech Micro** remote station support.
- Alarm handling and printing.
- Alarm logs.
- Controller support.
- DDE support.
- Network support.
- Up to 512 on/off software controllers each with:
 - Set point with differential adjustment.
 - Deviation high and low alarms.

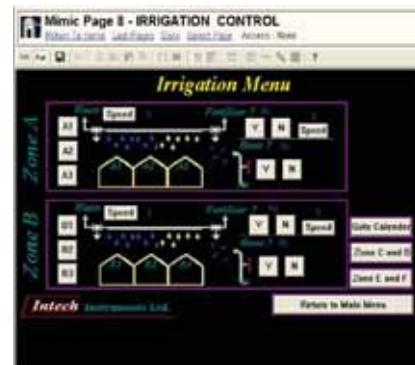

Controller Module

- Up to 99 Shimaden controllers.
- Complete set up and monitoring of controllers and indicators.



PLC Interface Module

- Allows communication between PLC's and Recorder/Mimic modules.
- Note:* Check with Intech engineers to ensure that the interface is available for the PLC to be used.



MicroScan Tool Box Module

- Data transfer.
- Mathematical formulas.
- Passwords.
- Audit tracking.
- Step controller.
- Time clocks.
- Data average & min/max.
- Time functions.
- Data base.
- Other special functions.
 - e.g. relative humidity.
 - cylindrical tank volume.
 - list – look-up table.
 - rate of change.

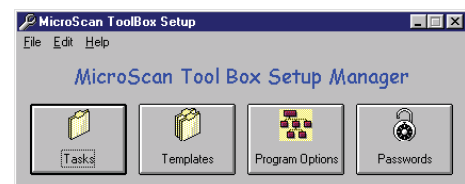

Network Module

- The ability to store files on a file server computer instead of the local computer to which the field hardware is connected.
- More than one computer can store files on the file server, these files can be picked up by any computer on the network with MicroScan installed.
- Price for the network module does not include the Network itself.
- Data file duplication for security.
- The Network should be installed and successfully running Windows before installing the MicroScan package.

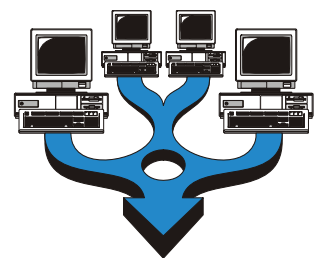

Software Modules (Version 5)

MicroScan Software "Recorder Packages". Comes complete with USB dongle.

Model	Description
R16	MicroScan recorder. 16 inputs, 16 outputs.
R32	MicroScan recorder. 32 inputs, 32 outputs.
R50	MicroScan recorder. 50 inputs, 160 outputs.
R100	MicroScan recorder. 100 inputs, 160 outputs.
R200	MicroScan recorder. 200 inputs, 160 outputs.
R300	MicroScan recorder. 300 inputs, 160 outputs.
R400	MicroScan recorder. 400 inputs, 160 outputs.
R600	MicroScan recorder. 600 inputs, 160 outputs.
R800	MicroScan recorder. 800 inputs, 160 outputs.
R1000	MicroScan recorder. 1000 inputs*, 160 outputs.

www.intech.co.nz/microscan



*Maximum recorder lines = 1000 made up of 100 pages with 10 lines on each page.

MicroScan Software "Tag Packages". Comes complete with USB dongle.
Includes: Recorder, Mimics, Shimaden and DDE.

Model	Description
T50	MicroScan software package. 50 tags.
T75	MicroScan software package. 75 tags.
T150	MicroScan software package. 150 tags.
T300	MicroScan software package. 300 tags.
T500	MicroScan software package. 500 tags.
T750	MicroScan software package. 750 tags.
T5000	MicroScan software package. 5000 tags.*
Note 1	Mimics (Only available with Tag option): No of pages: 100 max. I/O per page: 380 max. Controllers: 500 on/off software controllers, Each with individual: Set point. Differential adjustment: Deviation alarms.
SYM	Symbol Factory Libraries for Mimics images



*Maximum Tags = 5000 (max I/O = 5000).



www.intech.co.nz/sym

Optional Software Modules. (Not for Recorder LITE 8, LITE 16 or LITE 32 Packages)

TB+	MicroScan Tool Box. Data transfer, mathematical formulas, time clocks, step controller, recipes, data base and remote editor.
PLC	PLC Interface - specify PLC make and model.
	Network Drivers.
P1	Active PC will support 1 Passive PC
P2	Active PC will support 2 Passive PC's
P3	Active PC will support 3 Passive PC's
P4	Active PC will support 4 Passive PC's
P5	Active PC will support 5 Passive PC's
P6+	Active PC will support 6 or more passive nodes.
	Version Upgrades (Example from V4 to V5). Are available. Also available are larger packages and/or modules upgrades.
	USB Dongle. MicroScan license tied to hardware dongle, not PC. Parallel dongle available on special request. Notes: - Software locking is no longer available! - Old Sentinel-C dongles are now redundant and must be returned to Intech.

www.intech.co.nz/toolbox

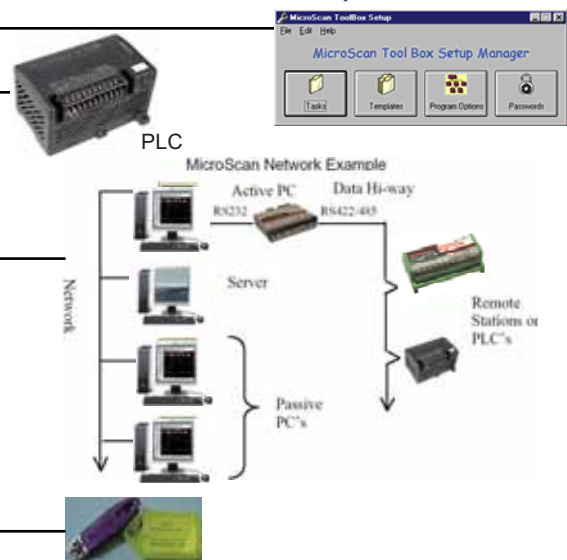

MICROSCAN MA5 MOBILE ALARM AND TEXT MESSAGING

Text messages allow you to keep in touch with your process

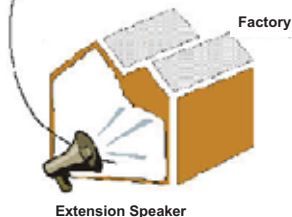
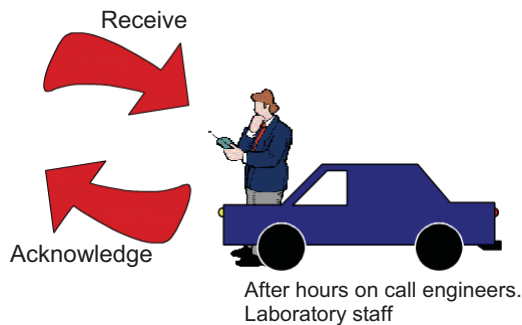
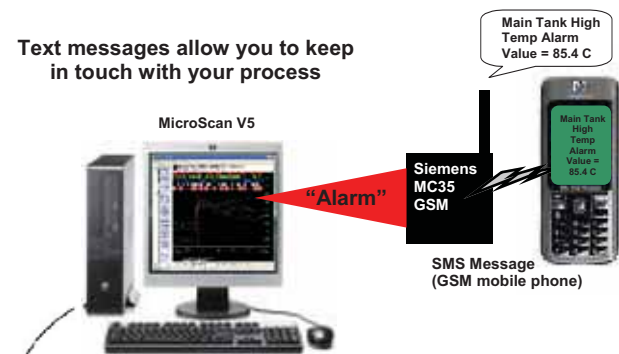

- Alarms immediately sent as text message to mobile phone and/or emailed.
- Alarms can be sent sequentially until acknowledged.
- Alarm message acknowledgment from mobile phone by returning alarm text message.
- Request any plant parameter by sending a text message from mobile phone.
- Commissioning / Critical parameters can be configured to be regularly sent as txt msg &/or email.
- Plant control settings can be adjusted from mobile phone via plant Mimics.
- A log file is kept of all communications and is stored on the PC for audit tracking.
- Daily email reports of activity.
- Send data automatically between two MicroScan V5 sites.
- One Siemens MC35 GSM Modem can connect to multiple MA5 clients across the network.

www.intech.co.nz/ma5

MicroScan MA5 (Mobile Alarming 5) software.	
Runs with MicroScan <u>Version 5</u> software & Microsoft .NET 2.0	
MODEL	DESCRIPTION
MA5	For MicroScan V5 software packages.
MA5-Lite	For MicroScan V5 LITE 8, LITE 16, LITE 32, R16 and R32 packages only. Includes all features of MA5.
MA5 MC35 Kit*	GSM message hardware kit add: * Does not include SIM card.

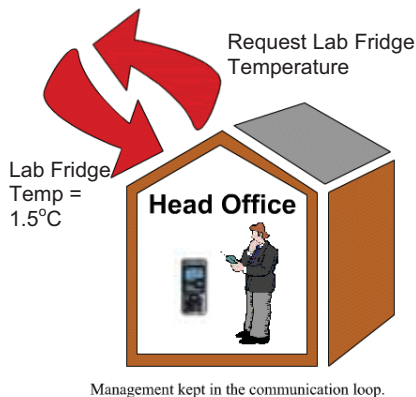

Features:

- Receive Alarms.
- Acknowledge Alarms.
- Check Alarms Acknowledged.
- Change Alarm setpoints, Delay, Enable/Disable.
- Monitor Critical Parameters.
- Request Plant Parameters.
- Change Plant Parameters.
- Activate Plant Equipment.

SHIMADEN LITE SOFTWARE

Features:

- User friendly controller configuration from computer.
- Auto seek: Finds controllers automatically.
- Auto configuration: Shimaden Lite automatically adopts controller configuration.
- Password protection.
- Trend graph of process value and set value.
- Trend graph has last 100 scans.
- Scan settings 1 sec, 15 sec, 1 min.
- Controller identification label.



Shimaden Controllers/ Indicators	
RS485 or RS232	RS422 or RS232
SR90 Series SD16A SR80 Series FP93 SR23 FP23 SRS10 Series MR13	FP21 SR25 SD20 SR253 SR73A
Notes: * The MR13 has no set value (SV) facility from the computer. * 2100-IS / 2100-NS not required when using RS232. * RS232 will connect to one controller only.	

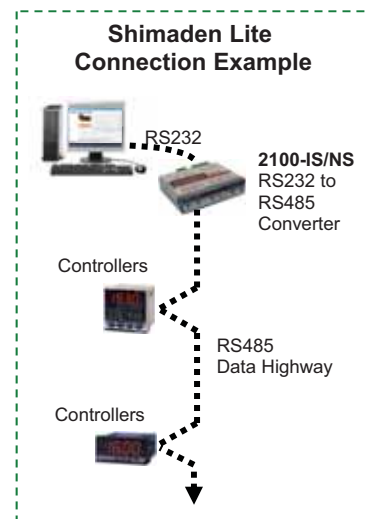

New WIRELESS MICROSCAN CONNECTIONS - ZIGBEE®

Wireless options

Which one suits your application: ZigBee® or Radio Modems?

ZigBee® is a new technology designed for short range mesh networking that allows easy expansion. Ideal for sites where wireless is preferred over cable connections. Applications: Hospitals, Labs, Blood banks and Industry.

Radio Modems are the traditional long range and high speed communications. Applications: Industry, Utilities, Environmental, Fresh and waste water.

MODEL	BENEFITS					COMMUNICATIONS	
	EASY EXPANSION	LOW COST	REDUNDANCY	LONG RANGE	HIGH SPEED	MICROSCAN	MODBUS RTU
ZigBee® Z-2400 Series	✓	✓	✓			✓	
Tel-Link Radio Modems				✓	✓	✓	✓

New Wireless ZigBee® Technology empowers MicroScan SCADA

Example showing MicroScan Software and the 2100-A16 Remote Stations plus Sleeper for mobile monitoring:

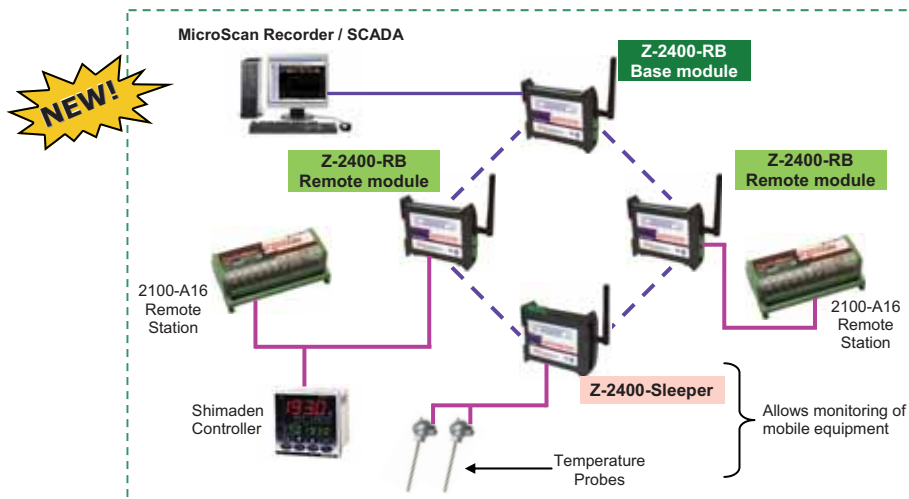

Z-2400 SERIES

Common Specifications:

- Wireless Standard: IEEE 802.15.4-2006.
- Wireless Range: Up to 100m max line of sight.
- Wireless Frequency: 2405~2485MHz.
- Frequency Hopping: 16 Channels.
- Wireless Power: 1mW
- Power supply: 9~35Vdc.
- Power Consumption: 5 VA.

MODEL	DESCRIPTION	For Ordering Code & Specifications:
Z-2400-RB	Communications: RS232, RS422, RS485. Duty: Configurable as Base or Remote. Embedded protocol support: MicroScan default ASCII.	www.intech.co.nz/zigbee
Z-2400-Sleeper	Universal channel data inputs: 2. Inputs: RTD/Tc/mV/V/mA/Pseudo Digital. Selectable update rate: 1, 2, 5, 15, 30, 60 minutes. Embedded protocol support: MicroScan default ASCII plus MODBUS RTU. Battery life: Approx 2 years life when wake up interval set to 2 minutes. Poor signal strength reduces battery life. Option to permanently power with plug pack power supply.	
Z-2400-TCP	Communications: Ethernet TCP. Duty: Base only. Embedded protocol support: MicroScan TCP plus Modbus TCP.	

Note: ZigBee® is a Registered trademark of the ZigBee Alliance, Inc.

2.4Ghz high gain antennas available on page 35. >>

WIRELESS MICROSCAN CONNECTIONS - 2.4GHz High Gain Antennas

MODEL	DESCRIPTION	
ZB-OD24-7 ZB-OD24-8 ZB-PG24-15	ZigBee® Antennas 2.4GHz Indoor 7dBi Omni Directional Rubber Duck Antenna. Outdoor 8dBi Omni Directional Monopole Antenna c/w 3m coax cable. Outdoor 15dBi Directional Parabolic Grid Antenna c/w 3m coax cable.	
TL-OD24-8 TL-PG24-15	Tel-Link Antennas 2.4GHz Outdoor 8dBi Omni Directional Monopole Antenna c/w 3m coax cable. Outdoor 15dBi Directional Parabolic Grid Antenna c/w 3m coax cable.	

Z-2400 Performance (2.4GHz)

- Indoor Urban: With Supplied Whip - Up to 100m.
- Outdoor Ideal* Conditions: With ZB-OD24-8 - Up to 1.5km.
With ZB-PG24-15 - Up to 4.5km.

Tel-Link Performance (2.4GHz)

- Outdoor Urban: With Supplied Whip - Up to 180m.
- Outdoor Ideal* Conditions: With TL-OD24-8 - Up to 5km.
With TL-PG24-15 - Up to 15km.

Notes:

- *Ideal conditions = mounted on 2 metre pole with line of sight and no surrounding trees or buildings, using supplied coax cable only.
- Test results show impressive distance results under ideal line of sight conditions. These distances are rapidly reduced when obstructions to 'line of sight' are experienced.
- Use only Intech ZB/TL Antennas with Intech wireless modules.
- For outdoor antennas, the supplied coax-seal must be used between exposed connections to protect from moisture corrosion.

WIRELESS MICROSCAN CONNECTIONS - Tel-Link Radio Modems

The **Tel-Link Radio Modems** are used for long-range, high speed wireless communications.

Features:

- MicroScan can now collect data from previously uneconomic areas.
- True peer-to-peer networking (no Master radio needed).
- Networking features allow up to 7 independent pairs (networks) to operate in close proximity.
- FCC and ETSI approved MaxStream radio modules.
- 2.4GHz license-free ISM band (Industrial, Scientific and Medical).
- Certified for use in Australia, USA, Canada, Europe and New Zealand.
- Spread spectrum type frequency hopping.
- Supports all MicroScan Interface baud rates (1200 to 57600 Baud).
- 19.2 kbps over-the-air data rates.
- Up to 65,000 network addresses available.
- Signal strength reporting for link quality monitoring and debugging.



MODEL	DESCRIPTION	For Ordering Code & Specifications:
TL-4850-24	Tel-Link Radio Modem 2.4GHz - RS 485/422 Outdoor c/w Outdoor 3dBi whip Antenna and 2m data cable. Supplied with a stainless steel mounting bracket and U bolts. Power supply requirements: 12Vdc @ 300mA.	www.intech.co.nz/tel-link
PSW-2-12-H	If you require a 12Vdc, 300mA power supply (100~264Vac Input).	www.intech.co.nz/psw-2

Note: Tel-Link Radio Modems can also be used with the data loggers on pages 36 to 40. >>

Example of Possible Set-Up:



DATA LOGGERS

- Stainless steel case.
- IP66 rating (excludes Humidity types).
- 1~5 year battery life (depending on usage).
- High Accuracy 12 bit or 16 bit.
- Over 500,000* readings can be stored!
- Sampling rate from 1 sec to 10 hrs.

MODEL	DESCRIPTION	For Ordering Code & Specifications:
T-HR	Single temperature. Internal temperature sensor. Range -30~70°C.	www.intech.co.nz/hr-loggers
HT-HR	Humidity and temperature. Humidity and internal temperature sensor. Range -30~70°C.	
THT-HR	Humidity and dual temperature. Range -30~70°C. *64,000 samples Humidity, one internal & one external temperature sensor.	
Tc-HR	Dual temperature, Thermocouple (Does not include probe). One internal and one external temperature sensor. Internal temperature sensor, range -30~70°C. External temperature sensor, Types J, K, N, R, T. Ranges -250~1760°C.	
HHT-03	Type K temperature probe for Tc-HR. Range -30~300°C. Spear probe 2m pvc cable with handle & mini plug. Others available, please contact Intech.	
Tc-HR Plug Set	70mm lead c/w plugs (Specify thermocouple type).	
Pt-HR	Dual temperature, Pt100 / Pt500 / Pt1000 (Does not include probe). One internal and one external temperature sensor. Internal temperature sensor, range -30~70°C. External temperature sensor, Pt100/Pt500/Pt1000, range -200~600°C.	
TP-Pt100	Pt100 temperature probe for Pt-HR, Range -100~150°C. 4.7 x 100mm SS probe with 2m tefzel cable.	
mV-HR mV-HR Lead	Milli-volt. Ranges: ±50mVdc, ±100mVdc, ±200mVdc, ±400mVdc. Test Lead Set.	
WT-HR-250 WT-HR-500 WT-HR-1000 WT-HR-1500 WT-HR-2000 316	Water level, air temperature and water temperature. Air temp. (-30~70°C). Water temp. (0~45°C). * 64,000 samples. To log water level between 0~0.25m. To log water level between 0~0.5m. To log water level between 0~1.0m. To log water level between 0~1.5m. To log water level between 0~2.0m. Option for 316 S/S for Salt water applications.	
pH-HR pH-HR Plug Set	pH and temperature. For use with a Pt100 temperature compensated pH probe (not included). See pages 42-43 for pH probes available from Intech. >> Fit plug set to pH sensor for use with pH-HR logger.	
GP-HR mA1-PS mA3+P-PS ##VD3-PS L-PS Pt3-PS P###-HR-PS Flow-mA2-PS ACM-mA2-PS	4 Input General Purpose Logger (Does not include sensors/plug sets) 3 Analogue inputs – individually configurable. 1 Digital pulse input channel. * Now over 1,000,000 8 bit samples, or over 500,000 12 bit samples. Standard External Sensors & Plug Sets for GP-HR: One 4~20mA or 0~20mA input. Three 4~20mA or 0~20mA inputs c/w One pulse input. Three DC voltage inputs. ## = Specify voltage up to 32Vdc. (Maximum voltage input for the GP-HR is 32Vdc (32VD3-PS) - for voltages >32Vdc use an intermediary transmitter like the PI-D). Light Energy. Three Pt1000 temp probes. Range = -50~130°C. (Logger maximum Pt1000 range is -100~400°C). Pressure probe - available ranges are: P100-HR-PS = -15~100psi, P250-HR-PS = -15~250psi, P500-HR-PS = -15~500psi. Coil or open collector plus two 4~20mA inputs. Flow metering off the pump run contact plus two 4~20mA inputs. <i>Note: Please contact Intech for other available options.</i>	
SWDL-DLC3USB SWDL-DLC3 DLC3USB DLC3	OmniLog Software and DLC3USB download cable Kit (USB). OmniLog Software and DLC3 download cable Kit (RS232). Spare HR Series download cable (USB). Spare HR Series download cable (RS232).	
HR-Battery mk3 HR-Battery mk4	Replacement HR Series Mark 3 Battery Kit. Replacement HR Series Mark 4 Battery Kit.	

View more data loggers on pages 38 & 39. >>

DATA LOGGERS

microToT Logger

- Small size.
- 7584 samples.
- Single internal temperature logger.
- Wide temperature range -20~70°C.
- Accuracy of $\pm 0.38^\circ\text{C}$ (0°C to 30°C).
- Start modes: On date/time or immediately.
- Logging modes: Each channel can be set to log all or any of the following:
 - Instantaneous readings, Average reading,
 - Maximum reading, Minimum reading.
- Continually connected to the computer for instant readings.
- Interrogation over phone lines using a standard modem link.
- Dial a pocket pager on an alarm condition.

	Model	Description	For Ordering Code & Specifications:
	microToT	Small Single Temperature Logger. Range -20~70°C, 7584 samples, accuracy = $\pm 0.38^\circ\text{C}$ (0°C to 30°C).	www.intech.co.nz/microtot
	SWDL-DLC1 DLC1	OmniLog Software and DLC1 download cable Kit (RS232) Spare microToT download cable (RS232).	

HR-Series Loggers	GP-HR General Purpose 4 channel logger
<ul style="list-style-type: none"> • Stainless steel case. IP66 rating (excludes Humidity types). • Over 500,000* readings can be stored! 1~5 year battery life. • A DLC3USB [USB] or DLC3 [RS232] download cable is required to connect HR Series loggers to a computer. • Sampling rate from 1 sec to 10 hrs in 1 second increments. • Each channel can be set to log all or any of the following: <ol style="list-style-type: none"> 1. Instantaneous readings. 2. Average reading. 3. Maximum reading. 4. Minimum reading. • Start modes: <ol style="list-style-type: none"> 1. On date/time. 2. Immediately. 3. On input condition. • Stop modes: <ol style="list-style-type: none"> 1. On date/time. 2. When memory is full. 3. Loop around (continues logging). • Continually connected to the computer for instant readings. • Interrogation over phone lines using a standard modem link. • Send SMS messages on an alarm condition. 	<p>Select any (up to four) of the following channels:</p> <ul style="list-style-type: none"> • Three analogue input channels, to log any combination of: <ol style="list-style-type: none"> 1. Temperature. 2. Humidity. 3. Pressure. 4. Light. 5. Voltage. 6. Current. 7. Wind direction. • One digital pulse input channel, to log: <ol style="list-style-type: none"> 1. Rainfall. 2. Wind speed. 3. Flow. 4. Counter (up to 65535) 5. Frequency (up to 60 kHz). • Internal temperature sensor channel may be activated to log the ambient temperature of the logger. • User replaceable battery. • Over 1,000,000 8 bit samples: or Over 500,000 12 bit samples! Over 600 days logging 3x Hi-Resolution. Channels every 5 minutes.  <p>www.intech.co.nz/gp-hr</p>

TruTrack OmniLog Software

- The TruTrack OmniLog Data Management software is an application for reading, displaying, analysing, organising and exporting data that has been downloaded from TruTrack data loggers (all types).
- Data can be read from data loggers or retrieved from previously saved data files.
- A connected data logger can be configured, calibrated, started, read and stopped by this application.
- Data retrieved from data loggers and previously saved data files can be viewed and printed in a values spread sheet list, as a graph or as a statistics report. These values, graphs and statistics can be displayed and printed for all data or from a user selected block of data.
- Data can also be exported in a large range of industry standard formats so as to be used by other applications.



www.intech.co.nz/omnilog



• Battery Status	• Graph & Values	• Offset Calibration
• Pager	• Exporting Datasets	• Sample Period
• Pager Alarm	• Graph Colors	• Channel & Probe Setup
• Graph	• Joining Graphs	• Change Dataset units
• Reports	• Light Energy	• High Precision Graph Draw
• Formats	• Pulse Input	• Quick Graph Draw
• Print	• Leaf Wetness	• Typographical Conventions
• Overviews	• Probe Selection	• Calibration Procedures
• Dew Point	• Saving Log Files	• Humidity Calibration
• Trips	• Serial Number	• Light Intensity Calibration limits
• Tutorial	• Dataset History	• Units & Scaling
• Log File	• Wind Chill Factor	• Displaying Real Time readings
• Log Status	• Real Time Screen	• Viewing Data in values
• Multi channel	• Modem Control	

MULTI PURPOSE DATA LOGGER

GP-MC Multi Purpose Data Logger

The GP-MC is a high resolution (12 bit) multi purpose data logger with eight analogue and two digital pulse inputs. It supports an additional 15 channels of input from remote sensors on an RS485 interface. It also provides a Start on Trigger input and two alarm outputs. The logger also has an integral internal temperature sensor which can be used to log ambient temperature if desired.

A **DLC5USB** [USB] or **DLC5** [RS232] download cable is required to connect the GP-MC logger to a computer.

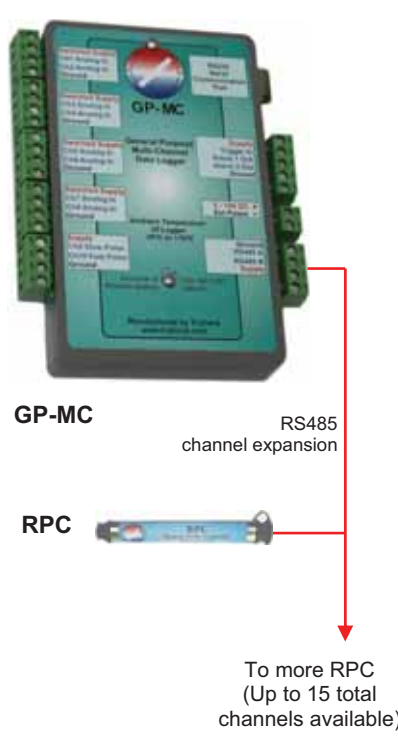
MODEL	DESCRIPTION	For Ordering Code & Specification Refer Web Page:
GP-MC	10 Input Multi Purpose Logger. 8 Analogue inputs – individually configurable. 2 Digital pulse input channel. 1,000,000 8 bit samples: 500,000 12 bit samples.	www.intech.co.nz/gp-mc
Seahorse	Option IP66 Weatherproof enclosure.	
Standard External Sensors & Plug Sets for GP-MC: Others available - contact Intech. GP-MC inputs are individually configurable using OmniLog. Each input requires conditioning using a 'Probe set'. Probe sets are per input as follows:		
mA-MC-PS 5VD-MC-PS 10VD-MC-PS	One 4~20mA or 0~20mA input. One 0~5Vdc input. One 0~10Vdc input. Maximum voltage input for the GP-MC is 32Vdc (32VD-MC-PS) - for voltages >32Vdc use an intermediary transmitter like the PI-D .	
Pt1000-MC-PS	Pt1000 temperature probe, Range = -50~130°C. (Logger maximum Pt1000 range is -100~400°C).	
P###-MC-PS	Pressure probe - available ranges are: P100-MC-PS = -15~100psi, P250-MC-PS = -15~250psi, P500-MC-PS = -15~500psi.	
Flow-MC-PS ACM-MC-PS	Coil or open collector. Flow metering off the pump run contact.	
	Note: Please contact Intech for other available 'probe set' options.	
RS485 expansion Options (15 total channels available).		
RPC	Remote Probe Controller (3x Analogue channels, 1x Fast Pulse channel) - uses same 'Probe Sets' as the GP-HR.	
SWDL-DLC5USB SWDL-DLC5 DLC5USB DLC5	OmniLog Software and DLC5USB download cable Kit (USB). OmniLog Software and DLC5 download cable Kit (RS232). Spare GP-MC download cable (USB). Spare GP-MC download cable (RS232).	

LCD DATA LOGGERS

LCD Series loggers are handheld, high resolution (16 bit) data loggers with a liquid crystal display. The LCD display allows the convenience of viewing realtime readings without having to connect the logger to a computer. The logger has an integral internal temperature sensor which can be used to log ambient temperature separately from the loggers main function if desired.

High accuracy and large storage capacity make the LCD series ideal for most industrial and commercial applications. LCD series loggers are designed for indoor use (IP40) but can be supplied with an optional IP66 Weather Proof Enclosure for outdoor use.

All TruTrack loggers will connect directly to a modem for remote downloading of data and can also send SMS messages on an alarm condition.

Features:

- Temperature can be set to any combination of Point, Average, Maximum & Minimum readings.
- Storage capacity of over 500,000 samples!
- High accuracy 16 Bit.
- 1 to 5 year battery life depending on usage, user replaceable. Data is retained in the event of battery failure. Battery status monitor on LCD display and in OmniLog software.
- User selectable sampling rate from 1 second to 10 hours in 1 second increments.
- Operating range of -20°C to +70°C (-4°F to +158°F).
- Dimensions = 130mm x 80mm x 30mm.
- Optional IP66 Weatherproof Logger Enclosure available for outdoor use.
- A **DLC8USB** [USB] or **DLC8** [RS232] download cable is required to connect LCD Series loggers to a computer.

MODEL	DESCRIPTION	For Ordering Code & Specification Refer Web Page:	
HT-LCD	Humidity and temperature. Range -30~70°C. Internal humidity and internal temperature sensor. ±3.0%RH accuracy from 20%RH to 80%RH.	www.intech.co.nz/lcd-loggers	
THT-LCD HT11-Probe HT15-Probe	Humidity and dual temperature. Range -30~70°C. Complete with HT11-Probe. External humidity with temperature, one internal temperature sensor. Digital humidity sensor with ±3.0%RH accuracy from 20%RH to 80%RH. Digital humidity sensor with ±2.0%RH accuracy from 10%RH to 90%RH. Humidity sensor probe cable length is 1.5m.		
Tc-LCD HHT-03	Accepts Type J, K, N, R and T thermocouple probes with Universal thermocouple connector socket. Ranges -250~1760°C. (Does not include probe). Type K temperature probe for Tc-LCD. Range -30~300°C. Spear probe 2m pvc cable with handle & mini plug. Others available, please contact Intech.		
Pt-LCD TP-Pt100-LCD	External RTD temperature sensor, range -200~600°C. (Does not include probe). Accepts Pt100, Pt500 and Pt1000 probes. Pt100 temperature probe for Pt-LCD. Range -100~150°C. 4.7 x 100mm SS probe with 2m tefzel cable. Others available, please contact Intech.		
P-LCD P100-PS P250-PS P500-PS	Pressure. Can display the pressure in kPa, Bar or psi on the LCD screen (more pressure display options are available when using OmniLog software). (Does not include pressure sensor). Pressure sensors available for the P-LCD - 500mm cable length: Pressure sensor. Range = -15~100psi (Overload 200psi, Burst 500psi) Pressure sensor. Range = -15~250psi (Overload 500psi, Burst 1250psi) Pressure sensor. Range = -15~500psi (Overload 1000psi, Burst 2500psi) All pressure sensors have 1/8 inch NPT thread.		
SWDL-DLC8USB SWDL-DLC8 DLC8USB DLC8	OmniLog Software and DLC8USB download cable Kit (USB). OmniLog Software and DLC8 download cable Kit (RS232). Spare LCD Series download cable (USB). Spare LCD Series download cable (RS232).		
OPTION			
Seahorse	IP66 Weatherproof enclosure for LCD Series logger outdoor use.		



End view of THT-LCD with external probe connected

ENVIRONMENTAL MONITORING SYSTEMS



Environmental Monitoring Systems are fully scalable, providing the flexibility of monitoring only the inputs needed for a given application. The systems use our popular and well tested general purpose data loggers, which means that inputs other than weather types can be also be logged if desired [E.g. 4~20mA or Voltage signal(s)]!

Small System

MODEL	DESCRIPTION	For Ordering Code & Specification Refer Web Page:
GP-HR-LB	GP-HR in L-Bar with attachment plate and two 50mm U bolts.	www.intech.co.nz/envsystems
OPTIONS:		
add any three of the following	add Ground Temp. add Air Temp and Humidity in Shield (Note: counts as two channels) add Leaf Wetness. add Solar Radiation. add Wind Direction. add 4~20mA input. add Voltage Input.	 <p>GP-HR-LB with Air and Humidity sensors in Shield & Solar Radiation sensor</p>
add any one of the following	add Windspeed. add Rain Gauge Input. add 1mm Rain Gauge. add 0.2mm Rain Gauge.	
SWDL-DLC3USB SWDL-DLC3 DLC3USB DLC3	OmniLog Software and DLC3USB download cable Kit (USB). OmniLog Software and DLC3 download cable Kit (RS232). Spare DLC3USB download cable (USB). Spare DLC3 download cable (RS232).	
Additional options:		
T-BAR	If you require Wind Speed and Direction, use a T-Bar rather than an L-Bar.	

<< Please refer to pages 36 & 37 for more information on the GP-HR general purpose data logger.

Medium System

MODEL	DESCRIPTION	For Ordering Code & Specification Refer Web Page:
GP-MC	10 Input Multi Purpose Logger. Option: IP66 Weatherproof Logger enclosure. add External Socket on Logger enclosure.	www.intech.co.nz/envsystems
OPTIONS:		
add any eight of the following	add Ground Temp. add Air Temp and Humidity in Shield (Note: counts as two channels). add Leaf Wetness. add Solar Radiation. add Wind Direction. add 4~20mA input. add Voltage Input.	  <p>Optional IP66 Logger Enclosure</p>
add any two of the following	add Windspeed. add Rain Gauge Input. add 1mm Rain Gauge. add 0.2mm Rain Gauge.	
add any five of the following	add Air Temp, Humidity, Pressure in Radiation Shield. add Air Temp, Humidity in Radiation Shield.	
Mounting	add L-Bar with attachment plate and two 50mm U bolts. add T-Bar with attachment plate and two 50mm U bolts.	
SWDL-DLC5USB SWDL-DLC5 DLC5USB DLC5	OmniLog Software and DLC5USB download cable Kit (USB). OmniLog Software and DLC5 download cable Kit (RS232). Spare GP-MC download cable (USB). Spare GP-MC download cable (RS232).	

<< Please refer to page 38 for more information on the GP-MC multi purpose data logger.

4~20mA WEATHER SENSOR TRANSMITTERS

Weather Sensor Transmitters are a tool for the observation and recording of meteorological data. The sensors can monitor air temperature, humidity, barometric pressure, light intensity, wind speed, wind direction and rainfall.

The output signals from the sensors are industrial standard 4~20mA (loop powered). This allows for easy integration into a SCADA or PLC monitoring system.

Individual Sensors

MODEL	DESCRIPTION	For Ordering Code & Specification Refer Web Page:
H-CL-E T-CL-E BP-CL-E LE-CL WS3-CL WS6-CL WD-CL RAIN-CL	Weather Sensor Transmitters. All with 4~20mA output signal. Humidity sensor c/w 1.5m cable. Temperature sensor c/w 1.5m cable. Barometric Pressure sensor c/w 1.5m cable. Light Energy sensor c/w base plate and 5m cable. Wind speed (3 cup Anemometer) c/w 10m cable (1.5m/sec starting speed). Wind speed (6 cup Anemometer) c/w 10m cable (0.45m/sec starting speed). Wind direction c/w 10m cable. 0.2mm Rain Gauge (4~20mA output via included PI-F transmitter).	www.intech.co.nz/weather
Mounting Options:		
LB TB Shield	L-Bar with attachment plate and two 50mm U bolts. T-Bar with attachment plate and two 50mm U bolts. Solar Radiation Shield - used for more accurate measurement of temperature, humidity and barometric pressure sensors. (Does not include Sensors). Must be attached to L-Bar or T-Bar.	



WS3-CL
Wind Speed
(3cup Anemometer)



WD-CL
Wind Direction



LE-CL
Solar Radiation /
Light Energy
(Pyranometer)



RAIN-CL
0.2mm Rain Gauge



Solar Radiation **Shield**
(shown attached to **LB** L-Bar)

Note: The L-Bar and T-Bar mounting arms have an attachment plate with holes that can be used for mounting to 50mm (2inch) or 25mm (1inch) diameter pipe or bolting to posts or buildings. The L-Bar and T-Bar are supplied complete with two 50mm (2inch) U bolts.



Fully Mounted Sensors

MODEL	DESCRIPTION
 WS3-WD-TB-CL with THP-CL option	Weather Sensor Transmitters. 4~20mA output signals. Wind speed 3 cup (starting speed = 1.5m/sec), wind direction, mounted on T-Bar mounting arm c/w 5m cable.
	Wind speed 3 cup (starting speed = 1.5m/sec), wind direction, light energy, mounted on T-Bar mounting arm c/w 5m cable.
	OPTIONS:
	WS6 Fit WS6 (Wind speed 6 cup), instead of WS3 on above T-Bar options (used for lower starting speed = 0.45m/sec).
THP-CL	Temperature, Humidity and Barometric Pressure sensors, all housed in Solar Radiation Shield c/w 5m cable, mounted on the above T-Bar options.

pH SENSORS

Model 10 - General purpose 1/2" NPT pH sensor

	Temperature: -5~80°C. Pressure: 0~100 psi. Cable length: 3 metres. Ref. Cell: Single junction, KCl/AgCl. Ref. Junction: Porous teflon. Applications: Non-toxic solutions e.g. Potable water, cooling towers, fresh/salt water aquariums.		
	MODEL	DESCRIPTION	For Ordering Code & Specifications:
	M-10	Model 10 General purpose 1/2" NPT pH sensor.	www.intech.co.nz/m10
	M-10-ORP	Model 10-ORP General purpose 1/2" NPT ORP sensor. Used for Redox measurement in relatively clean waters.	

Model 11- General purpose 3/4" NPT pH sensor

	Temperature: 0~80°C. Pressure: 0~100 psi. Cable length: 3 metres. Ref. Cell: Double junction, KNO ₃ and KCl/AgCl. High resistance to electrode poisoning solutions. Applications: For both submersible and insertable use in process and waste water.		
	MODEL	DESCRIPTION	For Ordering Code & Specifications:
	M-11	Model 11 General purpose 3/4" NPT pH sensor.	www.intech.co.nz/m11
	M-11-Pt100	Model 11-Pt100 General purpose 3/4" NPT pH sensor. Includes a Pt100 sensor.	
	M-11-Pt100-HT	Model 11-Pt100-HT General purpose 3/4" NPT pH sensor High temp. version including a Pt100 sensor. High temperature: 0~110°C. High pressure: 0~150 psi. Do not use where ethers, ketones and most aromatic hydrocarbons are present. If these solvents are present use the standard version regardless of the temperature.	
M-11-ORP	Model 11-ORP General purpose 3/4" NPT ORP sensor. Used for Redox measurement in waste water treatment. Platinum sensing element.		

Model 12 - General purpose 3/4" NPT pH sensor for flowing, viscous applications

	Temperature: 0~80°C. Pressure: 0~100 psi. Cable length: 3 metres. Ref. Cell: Double junction, KNO ₃ and KCl/AgCl. High resistance to electrode poisoning solutions. The concave sensor configuration protects the pH bulb from particulate matte and provides a cleansing flow without affecting the line pressure characteristics. Applications: Ideal for pipelines with flow velocities greater than 30 cm/sec. Typical applications include batching and process control in the chemical, petro-chemical, pulp/paper and electroplating industries.		
	MODEL	DESCRIPTION	For Ordering Code & Specifications:
	M-12	Model 12 General purpose 3/4" NPT pH sensor.	www.intech.co.nz/m12
	M-12-Pt100	Model 12-Pt100 General purpose 3/4" NPT pH sensor. Includes a Pt100 sensor.	
M-12-Pt100-HT	Model 12-Pt100-HT General purpose 3/4" NPT pH sensor High temp. version including a Pt100 sensor. High temperature: 0~110°C. High pressure: 0~150 psi. Do not use where ethers, ketones and most aromatic hydrocarbons are present. If these solvents are present use the standard version regardless of the temperature.		

NOTE: For alkaline conditions between pH 7~13 use the -HT option. For conditions above pH 13 contact Intech.

<< Please refer to page 36 for our pH-HR data logger - ideal for use with these pH probes!
 (We recommend the probes that include the -Pt100 option for best possible accuracy with the LPI-pH and pH-HR)

pH SENSORS

Model 21-General purpose 3/4" NPT pH sensor with long insertion length.

	Temperature: 0~80°C. Pressure: 0~100 psi. Cable length: 3 metres. Ref. Cell: Double junction, KNO ₃ and KCl/AgCl. High resistance to electrode poisoning solutions, typically those with cyanide, ammonia, sulphide and heavy metals in appreciable concentrations. Applications: A combination pH sensor for insertion in tanks and large diameter pipes using process and waste water.		
	MODEL	DESCRIPTION	For Ordering Code & Specifications:
	M-21	Model 21 General purpose 3/4" NPT pH sensor with long insertion length.	www.intech.co.nz/m21
	M-21-Pt100	Model 21-Pt100 General purpose 3/4" NPT pH sensor with long insertion length. Includes a Pt100 sensor.	
	M-21-Pt100-HT	Model 21-Pt100-HT General purpose 3/4" NPT pH sensor with long insertion length. High temperature version including a Pt100 sensor. High temperature: 0~110°C. High pressure: 0~150 psi. Do not use where ethers, ketones and most aromatic hydrocarbons are present. If these solvents are present use the standard version regardless of the temperature.	
	OPTION:		
ZT450	Cleaning Cage Kit.		
Note: Sensors must be ordered with the SCO option.			

NOTE: For alkaline conditions between pH 7~13 use the -HT option. For conditions above pH 13 contact Intech.

<< Please refer to page 36 for our pH-HR data logger - ideal for use with these pH probes!
 (We recommend the probes that include the -Pt100 option for best possible accuracy with the LPI-pH and pH-HR).

pH TRANSMITTER

- 4~20mA loop powered.
- LCD display.
- 2 kV isolation.
- 0.1% accuracy.
- 40~200mV output test signal.
- LED indication of loop current.
- IP67 enclosure.

	MODEL	DESCRIPTION	For Ordering Code & Specification Refer Web Page:
	LPI-pH	pH voltage to DC isolating transmitter with LCD display. pH milli volt input and Pt100 temperature compensation. Slope and offset adjustments for on site calibration.	www.intech.co.nz/lpi-ph

	0	ACID			NEUTRAL			ALKALINE			14				
		H+			7			OH-							
pH	0	1	2	3	4	5	6	7	8	9	10	11	12	13	14
mV at 25°C	+413							0							-413

Intech Instruments Ltd CONDITIONS OF SALE

Note: These terms and conditions apply to all future transactions between Intech Instruments Limited and you.

1. **Prices:** All prices are based on the factory price list as held by Intech at date of quotation, and also on rates of duty and primage, basic wages, freight, insurance and foreign exchange fluctuations at date of quotation. Any increase between the date of quotation and the date of delivery in direct costs other than the factory price resulting from variation in any of these factors or any other factor beyond the reasonable control of Intech shall be payable by the purchaser, provided the Buyer may cancel the Agreement within 7 days of notice of any increase in price. All prices quoted unless otherwise specified are in New Zealand dollars.
2. **Validity:** Unless previously withdrawn our quotation is open for acceptance for the period stated therein, or when no period is stated, within 30 days only from the date thereof, and is subject to confirmation by Intech at the time of such acceptance. The quotation is not deemed to have been accepted until all information required for indenting or ordering of items has been received.
3. **Government Approval or Import License:** Our quotation is subject to the availability of any necessary Government Approval or Import Licences and in the event of such approval or Licence not being forthcoming after reasonable efforts have been made by Intech, Intech may at its option determine the contract of sale and neither party shall have any claim against the other in respect thereof.
4. **Delivery:** Where a delivery period is quoted the period will commence when the purchaser accepts or is deemed to have accepted the quotation or upon the granting of Government approval or Import Licence where necessary or (where requested by Intech) upon receipt by Intech of all necessary information and drawings to enable the work to be put in hand whichever is the later. In no circumstances shall Intech be liable for late delivery by reasons of fire, strike, stoppages of work, war, Government action, transport delays, acts of God, shortages of supplies or manufacturers delays or any other cause whatsoever beyond Intech's control. Delivery shall be deemed to be made to the Buyer when the goods are despatched from Intech's premises or at the time when the Buyer is advised of the availability of the goods for dispatch in the event of the Buyer being unable to take delivery immediately. Where the goods are to be supplied and installed by Intech, delivery shall be deemed to be made when the goods are supplied and delivered to the Buyer's premises. Where it is agreed that the goods may be delivered by instalments each delivery is to be regarded as a separate contract and price payable accordingly. Failure of the Buyer to pay for one or more instalments of goods on due dates shall entitle Intech at its option to: a) suspend further deliveries pending payment; and or b) treat the agreement as repudiated by the Buyer.
5. **Passing of Risk:** Risk passes from Intech to Buyer on delivery from which time the goods shall be at the sole risk of the Buyer notwithstanding that payment for such goods may be payable in whole or in part at a later date.
6. **Property in the goods:** Until payment of the whole of the purchase, the property of the goods shall not pass to the Buyer notwithstanding that the risk has passed to the Buyer on delivery as aforesaid. Pending full payment, the Buyer agrees to hold the equipment as bailee and in default of payment on the due date of any instalment to return goods in good order and condition to the company.
7. **Insurance and Transportation:** All insurance and transportation charges after delivery are the responsibility of the Buyer. Where requested, Intech will arrange transport and insurance for the goods on behalf of the Buyer and the cost thereof shall be paid by the Buyer
8. **Damage, etc:** Inspection of the goods shall be made by the Buyer immediately upon delivery and in the event of damage, incorrect execution or shortage, the Buyer shall notify Intech in writing within 3 days of receipt of goods, and shall similarly notify the carrier in the case of damage or shortage of goods. Intech shall not be liable in respect of damage or shortage caused in transit, but any insurance arranged as in clause 7 hereof shall be applicable. The Buyer shall afford Intech the opportunity to inspect the goods within a reasonable time following notice and before any use is made. If the Buyer fails to comply with the provisions the goods are conclusively presumed in accordance with the agreement and free of any defect/damage apparent on reasonable examination and the Buyer has deemed to have accepted them.
9. **Payment:** Payment must be tendered to Intech in New Zealand currency at the registered office of Intech by the 20th of the month following the month in which the goods were despatched. Unless stated to the contrary Intech reserves the right to charge interest at 10% per annum on overdue accounts.
10. **Guarantee:** Equipment supplied by Intech Instruments Ltd, unless otherwise stated, is guaranteed against faulty workmanship and material for twelve months from the date of dispatch from Intech's premises. Intech's responsibility is limited to the replacement of defective parts whether the work is carried out on site or at Intech's premises. Equipment may be repaired under guarantee on site or at Intech's premises providing the equipment is returned to Intech freight paid. If the repairs are carried out on site travelling and accommodation costs may be charged at ruling rates. Should Intech be called upon to carry out work under guarantee and find that the fault is not due to faulty workmanship or materials on Intech's part then any costs involved will be added to the contract price and charged accordingly.
11. **Limitation of Liability:** Intech's liability to you is strictly limited to its obligations under the guarantee. Intech accepts no responsibility for any other damage loss or losses arising from or in any way connected with the goods supplied or services provided whether directly or indirectly and whether by way of consequential loss or otherwise howsoever. If despite the exclusions of liability in this clause Intech is found to be liable to you, the liability shall be limited to the value of the goods or services supplied by Intech to which the claim relates.
12. **Errors:** Quotations are subject to correction by Intech for omissions and typing errors.
13. **Definition:** Wherever the word "Intech" is used it shall be deemed to extend to and include Intech Instruments Limited or its successor or assign.

**Due to on going research and development, designs, specifications, and documentation are subject to change without notification.
No liability will be accepted for errors, omissions, or amendments to specifications.
Prices are standard packaging and ex Intech's store, freight is an additional charge.
Temperature probes do not have a warranty.**

Intech Instruments Ltd			
Office Location: 59 Mandeville Street Riccarton Christchurch 8011 New Zealand	Postal Address: PO Box 8568 Riccarton Christchurch 8440 New Zealand	Phone +64 3 343-0646 Fax +64 3 343-0649 Email export@intech.co.nz	

VISIT OUR WEBSITE

www.intech.co.nz